

# RCA-SA6C

ROBO Cylinder, Slider Type, Actuator Dimensions 58mm, 24V Servo Motor, Coupling Specification

Model Description **RCA** - **SA6C** - [ ] - **30** - [ ] - [ ] - **A1** - [ ] - [ ]

Series — Type — Encoder category — Motor category — Lead — Stroke — Applicable controller — Cable length — Option

I: Incremental specifications  
A: Absolute Specifications

30: Servo Motor 30W

12: 12mm  
6: 6mm  
3: 3mm

50:50mm to 600:600mm (Every 50mm pitch setting)

A1:ACON  
ASEL

N: None  
P: 1m  
S: 3m  
M: 5m  
X□ : Specified length  
R□ : Robot cable

Following options Refer to price table

See preceding section for model descriptions.

Compatible with rapid acceleration and deceleration (except for 3mm lead)

For low power applications



Technical Reference P.451

- POINT**  
Notes on selection
- (1) When the stroke increases, the maximum speed will drop to prevent the ball screw from reaching a critical speed. Use the actuator specification table below to check the maximum speed at the stroke you desire.
  - (2) The standard specification/energy savings for a load is 0.3G (with Lead 3 at 0.2G) and the maximum high acceleration/deceleration is 1G (with Lead 3 left out) as shown in the below table. (When acceleration/deceleration is dropped, the maximum payload values are shown in the table below.)

## Actuator Specifications Table

### Lead and Load Capacity

Model	Motor output (W)	Lead (mm)	Maximum payload		Rated thrust (N)	Stroke (mm)
			Horizontal (kg)	Vertical (kg)		
RCA-SA6C-[1]-30-12-[2]-A1-[3]-[4]	30	12	6	1.5	24.2	50 to 600 (each 50mm)
RCA-SA6C-[1]-30-6-[2]-A1-[3]-[4]		6	12	3	48.4	
RCA-SA6C-[1]-30-3-[2]-A1-[3]-[4]		3	18	6	96.8	

Legend [1] Encoder Type [2] Stroke [3] Cable Length [4] Option

### Stroke and Maximum Speed

Stroke / Lead	50 to 450 (each 50mm)	500 (mm)	550 (mm)	600 (mm)
	12	800	760	640
6	400	380	320	270
3	200	190	160	135

(Unit: mm/s)

### [1] Encoder Type and [2] Stroke Price Table

[2] Stroke (mm)	Type symbol	
	SA6C	
	[1] Encoder Type	
	Incremental	Absolute
50	I	A
100	—	—
150	—	—
200	—	—
250	—	—
300	—	—
350	—	—
400	—	—
450	—	—
500	—	—
550	—	—
600	—	—

### [4] Option Price Table

Name	Option mark	Reference page	Standard price
Brake	B	—	—
Foot bracket	FT	—	—
High acceleration/deceleration	HA	—	Free
Home check sensor	HS	—	—
Saves electric power	LA	—	Free
Reversed-home specification	NM	—	Free
Specification for Slider Roller	SR	—	—

\* High acceleration, deceleration capability cannot be used with roller specifications for slider part.  
\* Lead 3 cannot be used for high acceleration, deceleration.  
\* High acceleration, deceleration capability cannot be used with electrical energy-saving capability.

### [3] Cable Length Price Table

Category	Cable mark	Standard price
Standard type	P (1m)	—
	S (3m)	—
	M (5m)	—
Specified length	X06 (6m) - X10 (10m)	—
	X11 (11m) - X15 (15m)	—
	X16 (16m) - X20 (20m)	—
	R01 (1m) - R03 (3m)	—
Robot Cable	R04 (4m) - R05 (5m)	—
	R06 (6m) - R10 (10m)	—
	R11 (11m) - R15 (15m)	—
	R16 (16m) - R20 (20m)	—

\*See P384 for information on maintenance cable.

### Actuator Specifications

Item	Details
Drive method	Ball screw $\phi$ 10mm, rolled C10
Positioning repeatability	$\pm$ 0.02mm
Backlash	0.1mm or less
Base	Material: Aluminum with alumite treatment
Allowable load moment	Ma: 8.9N·m Mb: 12.7N·m Mc: 18.6N·m
Overhang load length	Ma direction: 220mm or less, Mb/Mc directions: 220mm or less
Ambient operating temperature, humidity	0 to 40°C, 85%RH or below (noncondensing)

Direction of allowable load moment

Overhang load length

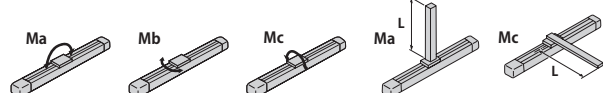

Dimensional Drawings

CAD drawings can be downloaded from the website. [www.intelligentactuator.com](http://www.intelligentactuator.com)

Information on special orders P.454



- \*1 Connect motor encoder cable. See P384 for details on cables.
- \*2 The slider moves to the ME during home return. Pay attention to prevent contact between the slider and surrounding parts.
- \*3 Reference position for calculating Ma moment

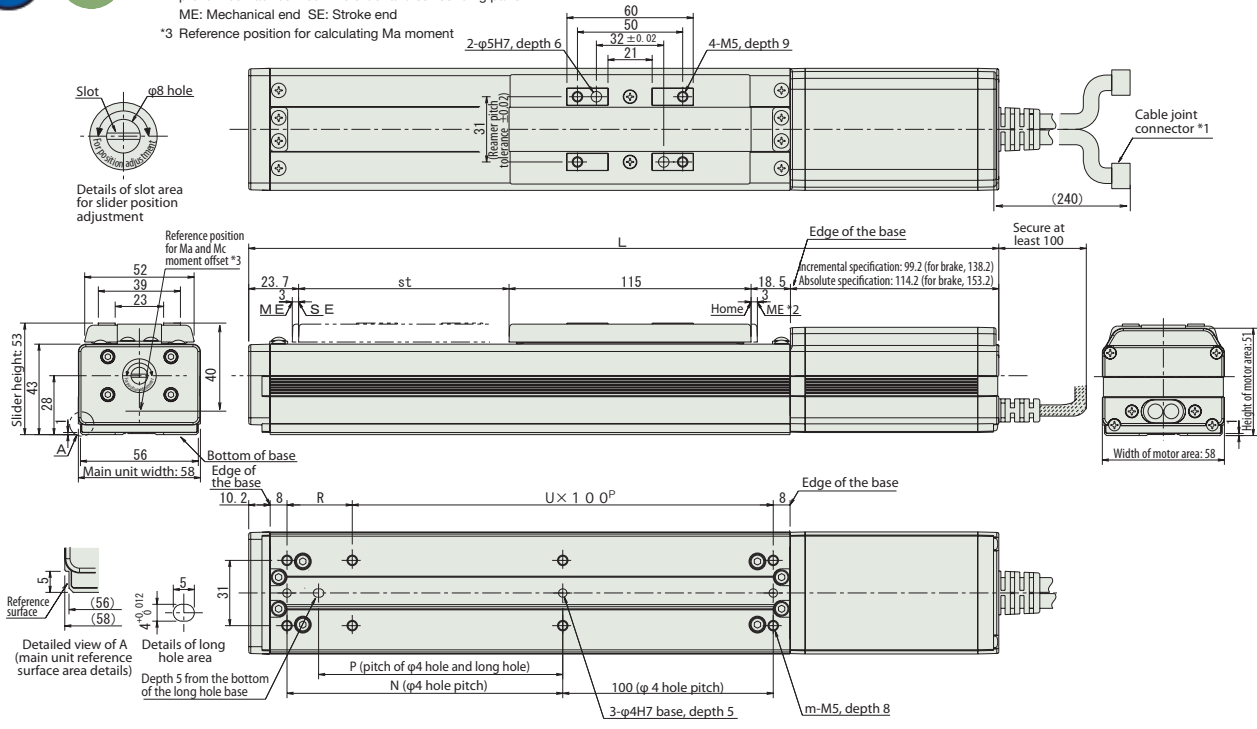

■ Dimensions and Weight by Stroke

Stroke		50	100	150	200	250	300	350	400	450	500	550	600	
L	Incremental	Without brake	306.4	356.4	406.4	456.4	506.4	556.4	606.4	656.4	706.4	756.4	806.4	856.4
		With brake	345.4	395.4	445.4	495.4	545.4	595.4	645.4	695.4	745.4	795.4	845.4	895.4
	Absolute	Without brake	321.4	371.4	421.4	471.4	521.4	571.4	621.4	671.4	721.4	771.4	821.4	871.4
		With brake	360.4	410.4	460.4	510.4	560.4	610.4	660.4	710.4	760.4	810.4	860.4	910.4
N		81	131	181	231	281	331	381	431	481	531	581	631	
P		66	116	166	216	266	316	366	416	466	516	566	616	
R		81	31	81	31	81	31	81	31	81	31	81	31	
U		1	2	2	3	3	4	4	5	5	6	6	7	
m		6	8	8	10	10	12	12	14	14	16	16	18	
Weight (kg)		1.4	1.6	1.8	2	2.2	2.4	2.6	2.8	3	3.2	3.4	3.6	

Compatible Controllers

The RCA series of actuators can operate with the following controllers. Please select a type that corresponds to your use.

Name	External view	Model	Features	Maximum number of positioning points	Input power supply	Power-supply capacity	Standard price	Reference page		
Positioner Type		ACON-C-30I(2)-NP-2-0	Maximum number of positioning points Positioning is possible.	512 points	DC24V	Rated 1.3A Peak 5.1A	—	P375		
For Safe Category Positioner Type		ACON-CG-30I(2)-NP-2-0								
Solenoid valve Type		ACON-CY-30I(2)-NP-2-0	Same as solenoid valve Operation possible with controller	3 points						
Pulse Train Input Type (Differential line driver specification)		ACON-PL-30I(2)-NP-2-0	Differential line driver specification Pulse train input type	(-)						
Pulse Train Input Type (Open collector specification)		ACON-PO-30I(2)-NP-2-0	Open collector specification Pulse train input type							
Serial Communications Type		ACON-SE-30I(2)-N-0-0	Serial communications Dedicated-use type	64 points						
Field Network Type		RACON-30(2)	Field network Dedicated-use type	768 points					—	P343
Program Control Type		ASEL-C-1-30I(2)-NP-2-0	Programmable type capable of operating up to 2 axes	1500 points						

\* The ASEL model name is based on a 1-axis specification.  
 \* (1) Indicates the encoder type (I: Incremental /A: Absolute) is needed.  
 \* (2) The mark (HA/LA) is entered when high acceleration/deceleration, energy saving capability is designated.

- Controller-Integrated
- Slider Type
- Rod Type
- Table Arm/Flat
- Gripper/Rotary Type
- Cleanroom
- Splash-resistant
- Controller
- Coupling
- Built-in (Direct)
- Reversed-mounted
- Pulse Motor 20P
- Pulse Motor 28P
- Pulse Motor 35P
- Pulse Motor 42P
- Pulse Motor 56P
- Pulse Motor 86P
- Servo Motor 10W
- Servo Motor 20W
- Servo Motor 30W
- Servo Motor 60W
- Servo Motor 100W
- Servo Motor 150W
- Servo Motor 750W