

RCS2-SA4C

ROBO Cylinder, Slider Type, Actuator Dimensions 40mm, Servo Motor, Coupling Specification

Model Description **RCS2** - **SA4C** - [] - **20** - [] - [] - [] - [] - []

Series — Type — Encoder category — Motor category — Lead — Stroke — Applicable controller — Cable length — Option

I: Incremental specifications
A: Absolute Specifications

20: Servo Motor 20W

10: 10mm
5: 5mm
2.5: 2.5mm

50:50mm to 400:400mm (Every 50mm pitch setting)

T1: XSEL-J/K
T2: SCON
SSEL
XSEL-P/Q

N: None
P: 1m
S: 3m
M: 5m
X□□ : Specified length
R□□ : Robot cable

Following options Refer to price table

See preceding section for model descriptions.

Compatible with rapid acceleration and deceleration

(Except for 2.5mm lead)

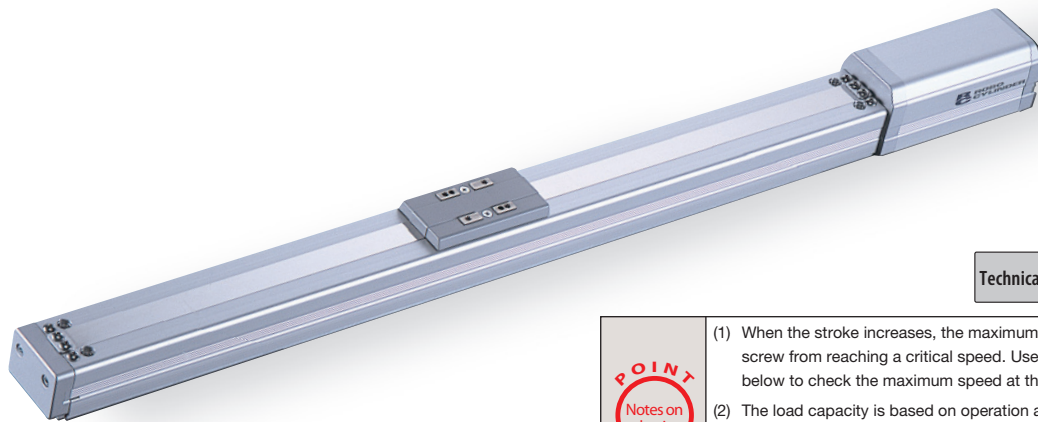

Technical Reference P.451

POINT
Notes on selection

- When the stroke increases, the maximum speed will drop to prevent the ball screw from reaching a critical speed. Use the actuator specification table below to check the maximum speed at the stroke you desire.
- The load capacity is based on operation at an acceleration of 0.3 G (or 0.2 G if the lead is 2.5). This is the maximum acceleration (except for lead 2.5). (When acceleration/deceleration is dropped, the maximum payload values are shown in the table below.)

Actuator Specifications Table

Lead and Load Capacity

Model	Motor output (W)	Lead (mm)	Maximum load capacity		Rated thrust (N)	Stroke (mm)
			Horizontal (kg)	Vertical (kg)		
RCS2-SA4C-①-20-10-②-③-④-⑤	20	10	4	1	19.6	50 to 400 (each 50mm)
RCS2-SA4C-①-20-5-②-③-④-⑤		5	6	2.5	39.2	
RCS2-SA4C-①-20-2.5-②-③-④-⑤		2.5	8	4.5	78.4	

Legend: ① Encoder category ② Stroke ③ Response controller ④ Cable length ⑤ Option

Stroke and Maximum Speed

Stroke / Lead	50 to 400 (each 50mm)	
	Stroke	50 to 400
10	665	665
5	330	330
2.5	165	165

(Unit: mm/s)

① Encoder type and ② Stroke Price Table

② Stroke (mm)	Type symbol SA4C	
	Encoder type	
	Incremental I	Absolute A
50	—	—
100	—	—
150	—	—
200	—	—
250	—	—
300	—	—
350	—	—
400	—	—

④ Cable Length Price Table

Category	Cable mark	Standard price
Standard type	P (1m)	—
	S (3m)	—
	M (5m)	—
Specified length	X06 (6m) - X10 (10m)	—
	X11 (11m) - X15 (15m)	—
	X16 (16m) - X20 (20m)	—
	R01 (1m) - R03 (3m)	—
Robot Cable	R04 (4m) - R05 (5m)	—
	R06 (6m) - R10 (10m)	—
	R11 (11m) - R15 (15m)	—
	R16 (16m) - R20 (20m)	—
	—	—

*See P394 for details on maintenance cable.

⑤ Option Price Table

Name	Option mark	Reference page	Standard price
Brake	B	P437	—
Foot bracket	FT	P440	—
High acceleration/deceleration	HA	P442	—
Home check sensor	HS	P442	—
Reversed-home specification	NM	P442	—
Specification for Slider Roller	SR	P445	—
Slider Spacer	SS	P445	—

* High acceleration, deceleration capability cannot be used with roller specifications for slider part.
* Lead 2.5 is not capable of high acceleration/deceleration.

Actuator Specifications

Item	Details
Drive method	Ball screw ϕ 8mm, rolled C10
Positioning repeatability	\pm 0.02mm
Backlash	0.1mm or less
Base	Material: Aluminum with alumite treatment
Allowable load moment	Ma: 2.7N·m Mb: 3.9N·m, Mc: 6.8N·m
Overhang load length	Ma direction: 120mm or less, Mb Mc direction: 120 mm or less
Ambient operating temperature, humidity	0 to 40°C, 85%RH or below (non-condensing)

Direction of allowable load moment

Overhang load length

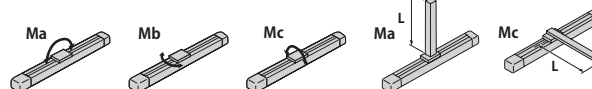

- Control-Integrated
- Slider Type
- Rod Type
- Table Arm/Flat
- Gripper/Rotary Type
- Cleanroom
- Splash-resistant
- Controller
- C Coupling
- D Built-in (Direct)
- R Reversed-
- Pulse Motor 20P
- Pulse Motor 28P
- Pulse Motor 35P
- Pulse Motor 42P
- Pulse Motor 56P
- Pulse Motor 86P
- Servo Motor 10W
- Servo Motor 20W
- Servo Motor 30W
- Servo Motor 60W
- Servo Motor 100W
- Servo Motor 150W
- Servo Motor 750W

Dimensional Drawings

CAD drawings can be downloaded from the website. www.intelligentactuator.com

Information on special orders P.454



- *1 Connect motor encoder cable. See P394 for details on cables.
- *2 The slider moves to the ME during home return. Pay attention to prevent contact between the slider and surrounding parts.
ME: Mechanical end SE: Stroke end
- *3 Reference position for calculating Ma moment

- *4 If the actuator is affixed using only the mounting holes provided in the top face of the base, the base may twist to cause abnormal sliding of the slider or noise. When the mounting holes in the top face of the base are used, keep the stroke to 200 mm or less

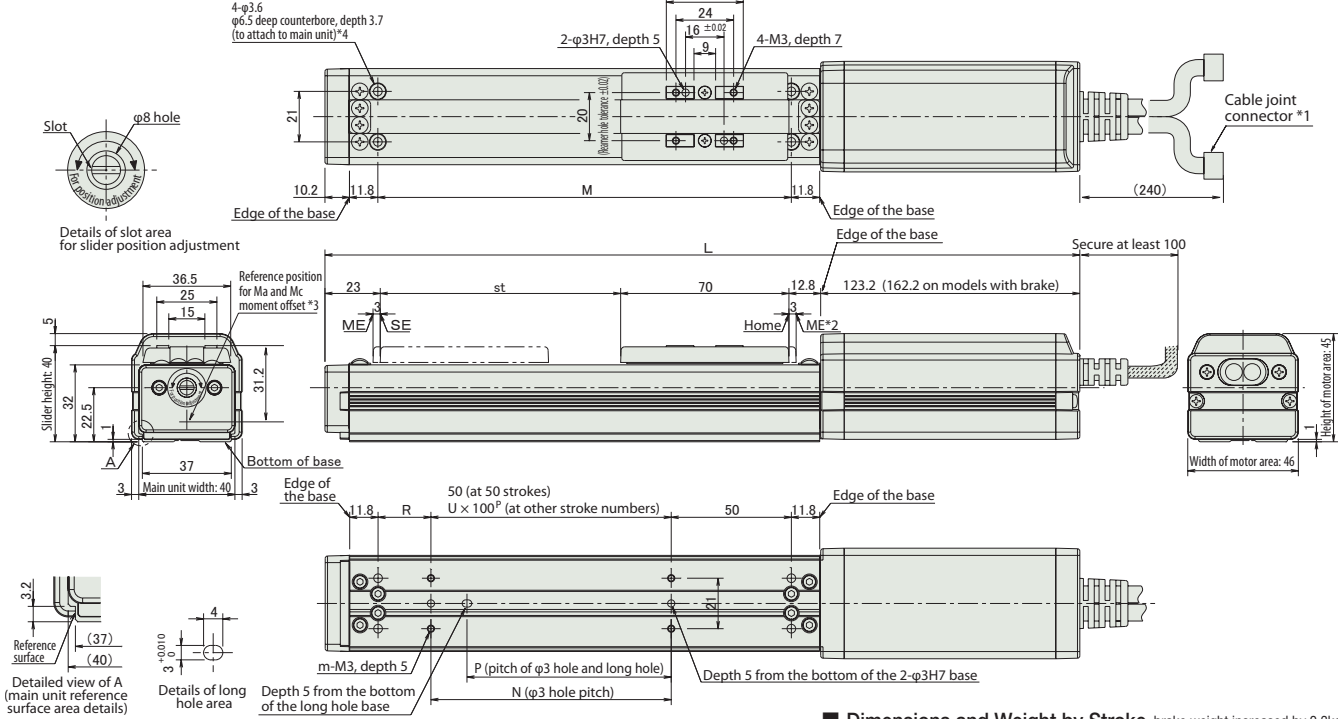

■ Dimensions and Weight by Stroke brake weight increased by 0.3kg.

Stroke	50	100	150	200	250	300	350	400	
L	Without brake	279	329	379	429	479	529	579	629
	With brake	318	368	418	468	518	568	618	668
M	122	172	222	272	322	372	422	472	
N	50	100	100	200	200	300	300	400	
P	35	85	85	185	185	285	285	385	
R	22	22	72	22	72	22	72	22	
U	-	1	1	2	2	3	3	4	
m	4	4	4	6	6	8	8	10	
Weight (kg)	0.7	0.8	0.9	1	1.1	1.2	1.3	1.4	

Compatible Controllers

RCS2 Series Actuators can be operated with the following controllers. Please select a type that corresponds to your use.

Name	External view	Model	Features	Maximum number of positioning points	Input power supply	Power supply capacity	Standard price	Reference page
Positioner Mode		SCON-C-20①②-NP-2-③	Maximum number of positioning points Positioning is possible.	512 points	Single-phase AC 100V Single-phase AC 200V 3-phase AC 200V (XSEL-P/Q only)	Maximum 360VA *1 axis specification For 150W operation	—	P385
Solenoid			Same as solenoid valve Operation possible with controller	7 points				
Serial Communications Type			Serial communications Dedicated-use type	64 points				
Pulsetrain input Control type			Pulse train input Dedicated-use type	(-)				
Program control 1-2 axis type		SSEL-C-1-20①②-NP-2-③	Programmable type Capable of operating up to 2-axis	20000 points			—	P415
Program control 1-6 axis type		XSEL-④-1-20①②-N1-EEE-2-⑤	Programmable type Maximum of 6-axis operation possible	4000 points			—	P425

*SSEL, XSEL is for 1-axis specification.
 *①) Indicates the encoder type (I: Incremental /A: Absolute) is needed.
 *②) The mark (HA) is needed to designate high acceleration/deceleration.
 *③) Power source voltage (1:100V/2:single-phase 200V) is needed.
 *④) XSEL type Name (J/K/P/Q) is needed.
 *⑤) Power source voltage type (1: 100V / 2: Single-Phase 200V / 3: 3-Phase 200V) is needed.