





Precision Regulator

Series IR1000/2000/3000

	Series	Model	Set pressure range	Port size	Page
Basic	Series IR1000 	IR1000	0.005 to 0.2MPa	1/8	126
		IR1010	0.005 to 0.4MPa		
		IR1020	0.005 to 0.8MPa		
	Series IR2000 	IR2000	0.005 to 0.2MPa	1/4	126
		IR2010	0.005 to 0.4MPa		
		IR2020	0.005 to 0.8MPa		
	Series IR3000 	IR3000	0.01 to 0.2MPa	1/4, 3/8, 1/2	126
		IR3010	0.01 to 0.4MPa		
		IR3020	0.01 to 0.8MPa		

- AC
- AV
- AU
- AF
- AR
- IR**
- VEX
- AW
- AMR
- AWM
- AWD
- ITV
- VBA
- VE
- VY
- G
- AL

Air Operated	Series IR2000 	IR2120	0.005 to 0.8MPa	1/4	126
	Series IR3000 	IR3120	0.01 to 0.8MPa	1/4, 3/8, 1/2	126

Precision Regulator

Series IR1000/2000/3000

Bracket and pressure gauge can be mounted from 2 directions

Mounting is possible on either the front or the back

Expanded regulating pressure range

The maximum set pressure has been expanded from the conventional 0.7MPa to 0.8MPa

Compact and light weight

IR1000 width 35mm weight 140g
(previously unavailable small size added)
IR2000 width 50mm weight 300g
(▲ width 14%, weight ▲6% Compared to SMC IR200)
IR3000 width 66mm weight 640g
(▲ width 21%, weight ▲36% Compared to SMC IR400)



Modular body introduced

Can be combined with AF (air filter) and AFM (mist separator).



Attachments such as a pressure switch can be mounted as accessories

Applicable modular sizes **IR1000**: Modular 2000 type
IR2000: Modular 3000 type
IR3000: Modular 4000 type

(Refer to p.1.1-17 for types of attachments.)

Superior relief flow characteristics

Relief flow has been increased by nearly 5 times (compared to SMC IR201, IR401)

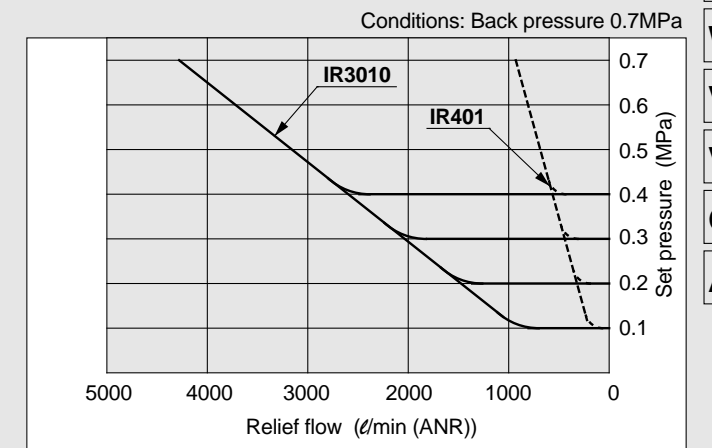
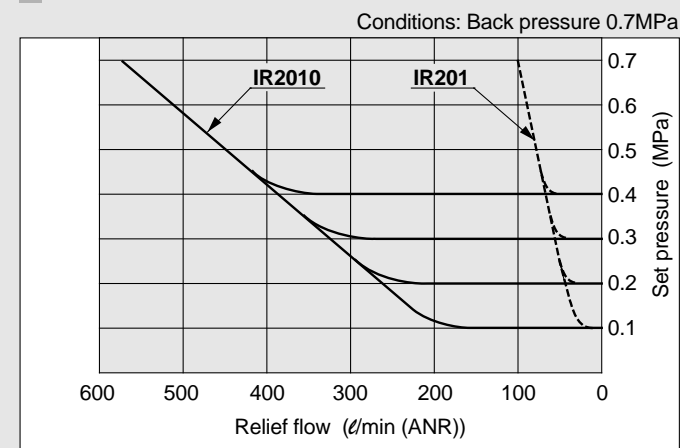

2 air operated models Air operated style added to series IR2000



IR2120

IR3120

Manifolding is possible

Made to order specifications (except series IR2120, IR3000)

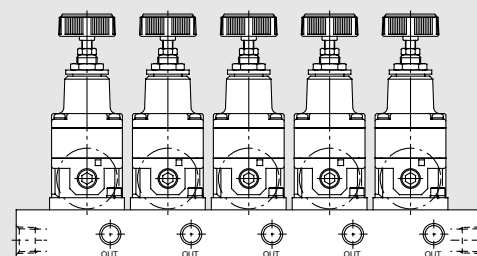

Series Variations

Specifications	Model	Basic		Air operated		
		IR10□0	IR20□0	IR30□0	IR2120	IR3120
Maximum set pressure	0.2MPa	●	●	●	—	—
	0.4MPa	●	●	●	—	—
	0.8MPa	●	●	●	●	●
Port size	Rc(PT) 1/8	●	—	—	—	—
	Rc(PT) 1/4	—	●	●	●	●
	Rc(PT) 3/8	—	—	●	—	●
	Rc(PT) 1/2	—	—	●	—	●

● Available — Not available

Made to Order Specifications

Symbol	Specifications/Content
10-	Clean room specifications
20-	Copper-free specifications
80-	Ozone resistant specifications
-T	For high temperature
-L	For low temperature
-X1	Non-grease specifications
IRM□□	Manifold (except series IR2120, IR3000)

* Refer to p.1.6-11 for details.

AC
AV
AU
AF
AR
IR
VEX
AW
AMR
AWM
AWD
ITV
VBA
VE
VY
G
AL

Application Examples

Constant fluid pressure

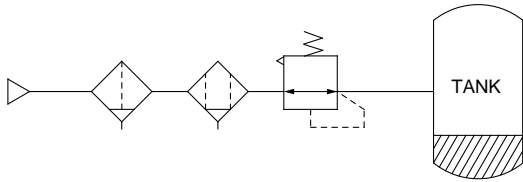

- Since there is a large effective area for supply and exhaust, pressure setting can be done quickly.

Balance and drive Accurate balance pressure setting

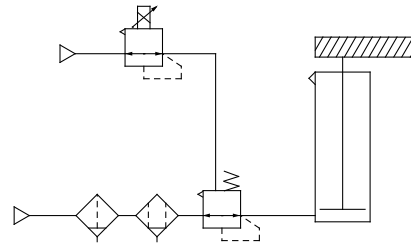

- Limits pressure fluctuation when driving a cylinder, maintaining excellent static and dynamic balance.

Accurate pressure setting – Sensitivity within 0.2%F.S. (full span) Tension controller

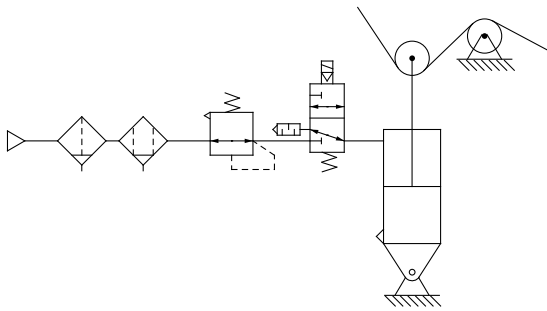

Contact pressure control

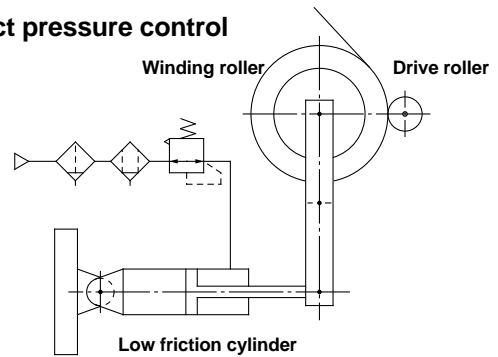

- Adapts to the cylinder's piston displacement, maintaining a constant pressure.

Multistage control of work piece pressing force (Wrapping machine)

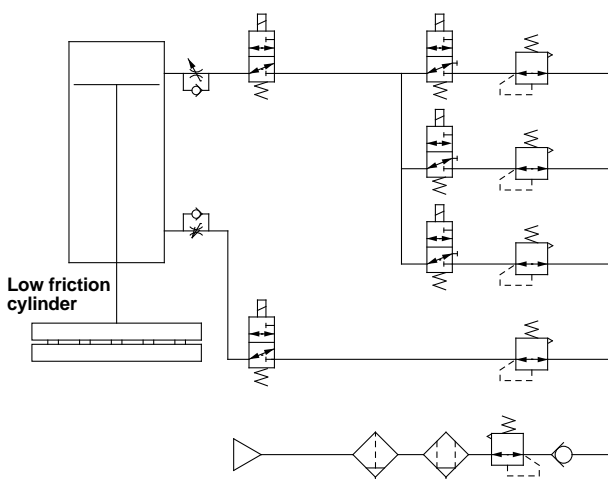

Leak test circuit

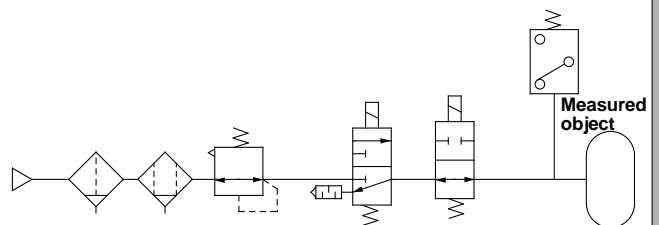

Precision Regulator

Series IR1000/2000/3000

JIS symbol

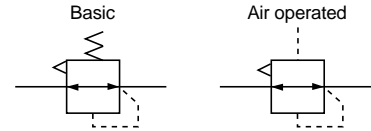

Standard Specifications

Model	Basic style			Air operated style	
	IR10□0	IR20□0	IR30□0	IR2120	IR3120
Max. supply pressure	Maximum 1.0MPa				
Min. supply pressure	Set pressure+0.05MPa ⁽¹⁾			Set pressure+0.1MPa	Set pressure+0.1MPa
Set pressure range	IR1000: 0.005 to 0.2MPa	IR2000: 0.005 to 0.2MPa	IR3000: 0.01 to 0.2MPa	0.005 to 0.8MPa	0.01 to 0.8MPa
	IR1010: 0.005 to 0.4MPa	IR2010: 0.005 to 0.4MPa	IR3010: 0.01 to 0.4MPa		
	IR1020: 0.005 to 0.8MPa	IR2020: 0.005 to 0.8MPa	IR3020: 0.01 to 0.8MPa		
Input signal pressure ⁽²⁾	—			0.005 to 0.8MPa	0.01 to 0.8MPa
Sensitivity	Within 0.2% of full span				
Repeatability	Within ±0.5% of full span				
Linearity ⁽³⁾	—			Within ±1% of full span	
Air consumption ⁽⁴⁾	5ℓ/min (ANR) or less (supply pressure: 1.0MPa)	4ℓ/min (ANR) or less (supply pressure: 1.0MPa)	Bleed port: 9.5ℓ/min (ANR) or less (supply pressure: 1.0MPa)	4ℓ/min (ANR) or less (supply pressure: 1.0MPa)	Bleed port: 9.5ℓ/min (ANR) or less (supply pressure: 1.0MPa)
		3ℓ/min (ANR) or less (supply pressure: 0.7MPa)	Exhaust port: 2ℓ/min (ANR) or less (at maximum set pressure)	3ℓ/min (ANR) or less (supply pressure: 0.7MPa)	Exhaust port: 2ℓ/min (ANR) or less (at maximum set pressure)
Port size	Rc(PT) 1/8	Rc(PT) 1/4	Rc(PT) 1/4, 3/8, 1/2	Rc(PT) 1/4	Rc(PT) 1/4, 3/8, 1/2
Pressure gauge port	Rc(PT) 1/8 (2 locations)				
Ambient and fluid temperature	- 5 to 60°C (No freezing)				
Weight (kg)	0.14	0.30	0.64	0.35	0.71

Note 1) With the condition of no flow on the output side. Together with the set pressure, be sure to maintain a minimum differential pressure of 0.05MPa for models IR1000 and IR2000, and 0.1MPa for model IR3000.

Note 2) Applicable only to air operated styles IR2120 and IR3120. The basic style is excepted.

Note 3) Indicates the linearity of the output pressure with respect to the input signal pressure.

Note 4) Air is normally being discharged to the atmosphere.

How to Order

IR 2000-02-R

Body size

1	IR1000
2	IR2000
3	IR3000

Type of setting

0	Basic (handle)
1	Air operated (series IR2000/3000 only)

Set pressure range

For series IR1000/2000

0	0.005 to 0.2MPa
1	0.005 to 0.4MPa
2	0.005 to 0.8MPa

Note) The air operated style is model IR2120 only.

For series IR3000

0	0.01 to 0.2MPa
1	0.01 to 0.4MPa
2	0.01 to 0.8MPa

Note) The air operated style is model IR3120 only.

Pressure gauge mounting

R Note) Pressure gauge mounted on reverse side

Note) The standard mounting position of the pressure gauge is on the front, when viewing the regulator with the SUP side to the left and the OUT side to the right.

Accessories

—	None
B	With bracket
G	With pressure gauge

Port size

Symbol	Size	Application		
		IR1000	IR2000	IR3000
01	1/8	●		
02	1/4		●	●
03	3/8			●
04	1/2			●

Thread style

—	Rc(PT)
N	NPT
F	G(PF)

- AC
- AV
- AU
- AF
- AR
- IR**
- VEX
- AW
- AMR
- AWM
- AWD
- ITV
- VBA
- VE
- VY
- G
- AL

Series IR1000/2000/3000

Specification Combinations

●: Standard specifications ○: Combination possible Blank: Combination not possible

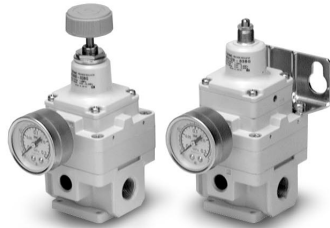

Series IR3000

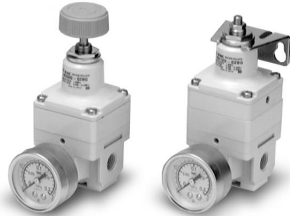

Series IR2000



Series IR1000

Specifications	Symbol	Applicable model					
		IR1000 IR1010 IR1020	IR2000 IR2010 IR2020	IR2120	IR3000 IR3010 IR3020	IR3120	
Standard specifications	Set pressure max. 0.2MPa	0	●	●		●	
	Set pressure max. 0.4MPa	1	●	●		●	
	Set pressure max. 0.8MPa	2	●	●	●	●	●
	Connection Rc(PT) 1/8	01	●				
	Connection Rc(PT) 1/4	02		●	●	●	●
	Connection Rc(PT) 3/8	03				●	●
	Connection Rc(PT) 1/2	04				●	●
Accessories	Bracket	B	○	○	○	○	○
	Pressure gauge	G	○	○	○	○	○
Optional specifications	Pressure gauge reverse mounted	R	○	○	○	○	○
	Connection NPT1/8	N01	○				
	Connection NPT1/4	N02		○	○	○	○
	Connection NPT3/8	N03				○	○
	Connection NPT1/2	N04				○	○
	Connection G(PF) 1/8	F01	○				
	Connection G(PF) 1/4	F02		○	○	○	○
	Connection G(PF) 3/8	F03				○	○
Connection G(PF) 1/2	F04				○	○	

Modular Products and Accessory Combinations

Description	Applicable model		
	IR10□0	IR20□0/IR2120	IR30□0/IR3120
① Air filter	AF2000	AF3000	AF4000
② Mist separator	AFM2000	AFM3000	AFM4000
③ L bracket	B210L	B310L	B410L
④ T bracket	B210T	B310T	B410T
⑤ Interface	Y20	Y30	Y40
⑥ Interface with L bracket (③ + ⑤)	Y20L	Y30L	Y40L
⑦ Interface with T bracket (④ + ⑤)	Y20T	Y30T	Y40T

<Combination example>

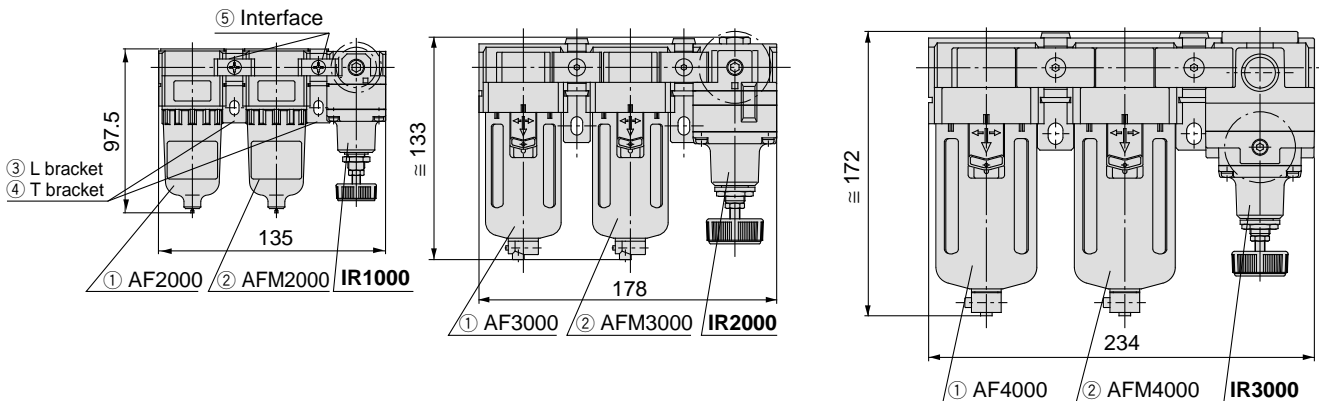

Accessories (Optional)

Description	Part No.								
	IR1000	IR1010	IR1020	IR2000	IR2010	IR2020 / 2120	IR3000	IR3010	IR3020/3120
Bracket	P36201023			P36202028			P36203018		
Pressure gauge*	G33-2-01	G33-4-01	G33-10-01	G43-2-01	G43-4-01	G43-10-01	G43-2-01	G43-4-01	G43-10-01

* Accuracy ±3% (full span)

Construction

IR1000

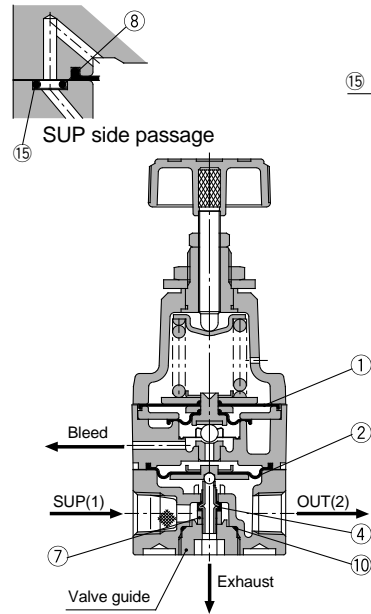

IR2000

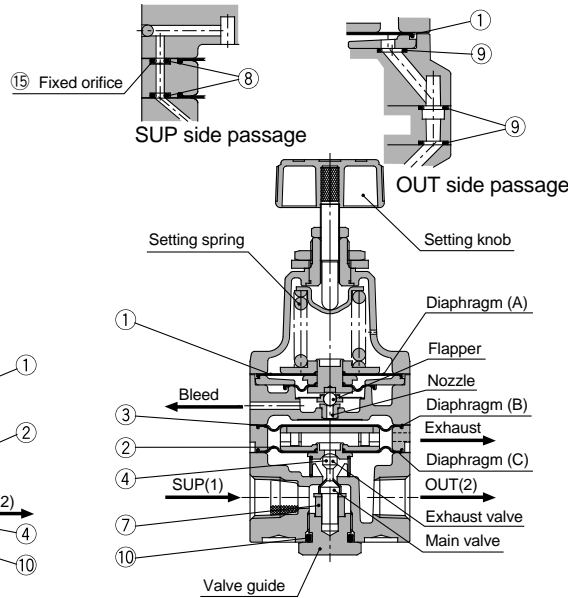

IR3000

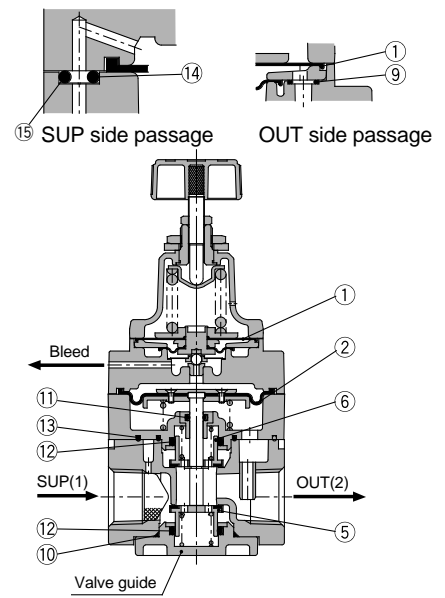

Operating Principles (for IR2000)

When the setting knob is turned, the nozzle is closed by the flapper allowing the supply air that flows in from the upstream side to pass through the fixed orifice and to act on diaphragm B as nozzle back pressure, the main valve is pushed down by the generated force and the supply pressure flows out to the downstream side. The air pressure that flows in acts on diaphragm C and while opposing the force generated by diaphragm B, it also acts on diaphragm A opposing the compression force of the setting spring and becomes the set pressure. If the set pressure rises too high, diaphragm A is pushed up, the interval between the flapper and the nozzle widens, the nozzle back pressure drops, the balance of diaphragms B and C is broken, the main valve closes, the exhaust valve opens and the excess pressure from the downstream side is discharged to the atmosphere. In this way fine pressure variations are detected by the nozzle/flapper style pilot mechanism, and precise pressure adjustment is performed.

IR2120

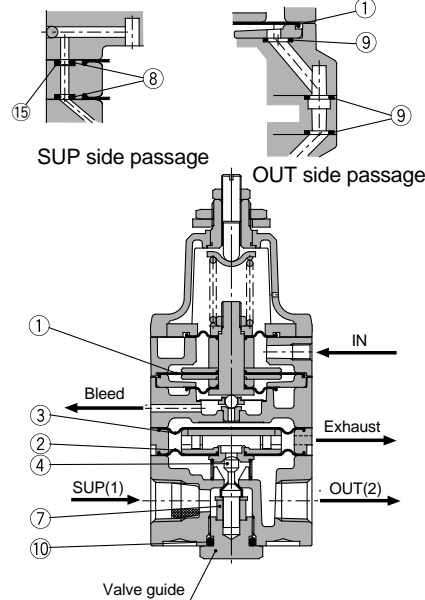

IR3120

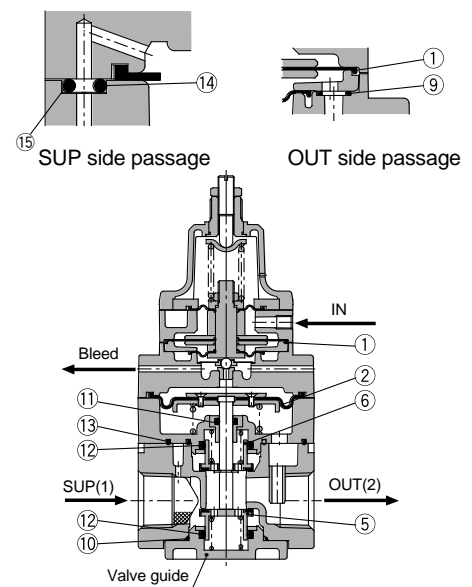

Replacement Parts

No.	Description	Material	Part No.				
			IR10□0	IR20□0	IR30□0	IR2120	IR3120
①	Diaphragm assembly	NBR, other	P362010-1	P362020-2	P362020-2	P362020-13	P362020-13
②	Diaphragm assembly	NBR, other	P362010-2	P362020-5	P362030-1	P362020-5	P362030-1
③	Diaphragm	NBR, other	—	P36202019	—	P36202019	—
④	Valve	Stainless steel, NBR	P36201020 (-1) ⁽¹⁾	P36202025	—	P36202025	—
⑤	Valve	Brass, NBR	—	—	P36203009	—	P36202009
⑥	Valve	Brass, NBR	—	—	P36203010	—	P36203010
⑦	Damper	NBR	P36201021	P36202026	—	P36202026	—
⑧	O ring	NBR	∅2.5 X 1	∅1.5 X 1.5	—	∅1.5 X 1.5	—
⑨	O ring	NBR	—	∅4.5 X 1	∅4.5 X 1	∅4.5 X 1	∅4.5 X 1
⑩	O ring	NBR	∅10 X 1.3	JISB2401 P11	∅27.8 X 1.5	JISB2401 P11	∅27.8 X 1.5
⑪	O ring	NBR	—	—	JISB2401 P5 ⁽²⁾	—	JISB2401 P5 ⁽²⁾
⑫	O ring	NBR	—	—	JISB2401 P16 ⁽²⁾	—	JISB2401 P16 ⁽²⁾
⑬	Seal (A)	NBR	—	—	P36203015	—	P36203015
⑭	Seal (B)	NBR	—	—	P36203016	—	P36203016
⑮	Fixed orifice	Stainless steel	P36202018	P36202018	P36203017	P36202018	P36203017
Service parts kit no. (set of above items 1 through 14)			KT-IR1000 ⁽³⁾ KT-IR1010	KT-IR2000	KT-IR3000	KT-IR2120	KT-IR3120

Note 1) IR1000 uses P36201020-1 and IR1010/1020 use P36201020.

Note 2) Use mini-flick style.

Note 3) IR1000 uses KT-IR1000 and IR1010/1020 use KT-IR1010.

AC

AV

AU

AF

AR

IR

VEX

AW

AMR

AWM

AWD

ITV

VBA

VE

VY

G

AL

Series IR1000/2000/3000

Flow characteristics

* Testing methods conform to JIS B8372.

IR1000-01 Conditions: Supply pressure 0.5MPa

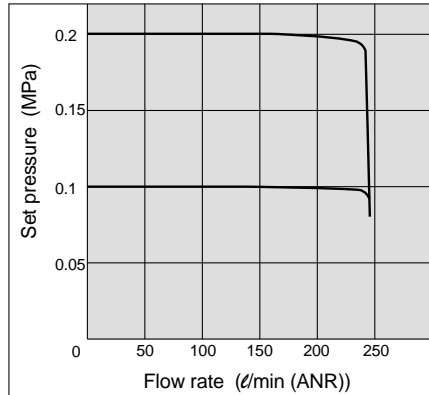

Relief characteristics

IR1000-01 Conditions: Back pressure 0.5MPa

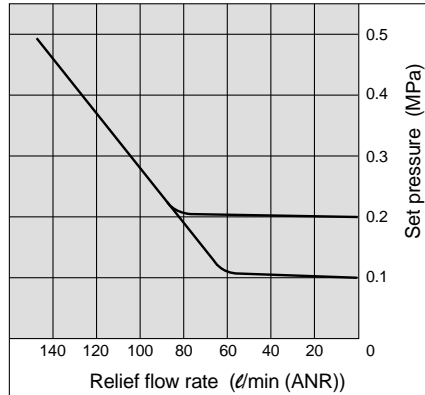

Pressure characteristics

Conditions: Supply pressure 0.7MPa
Set pressure 0.2MPa
Flow rate 0 l/min (ANR)

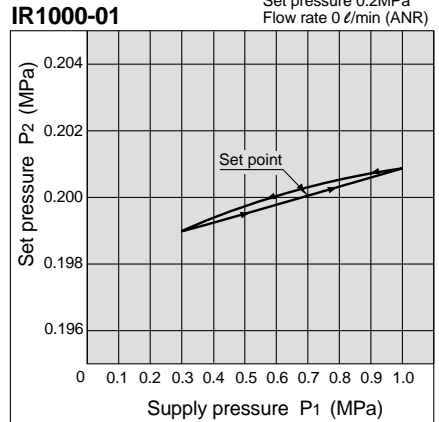

IR1010-01 Conditions: Supply pressure 0.7MPa

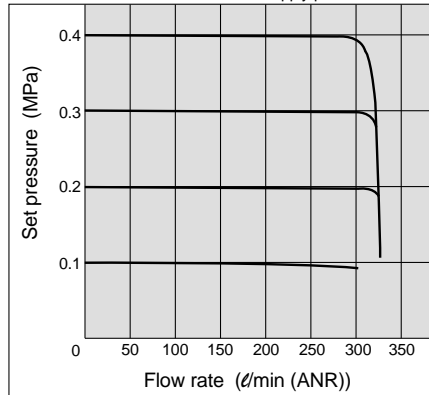

IR1010-01 Conditions: Back pressure 0.7MPa

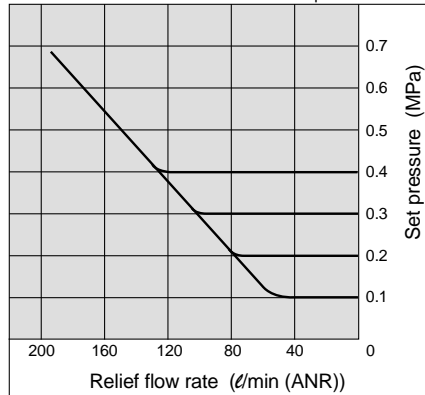

IR1010-01

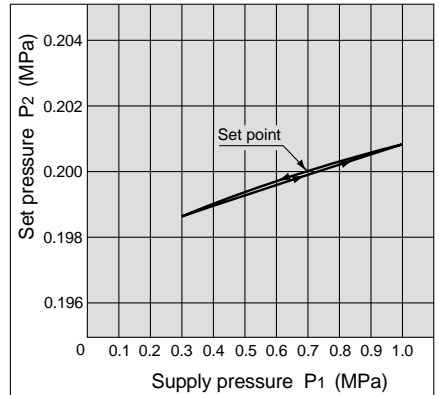

IR1020-01 Conditions: Supply pressure 1.0MPa

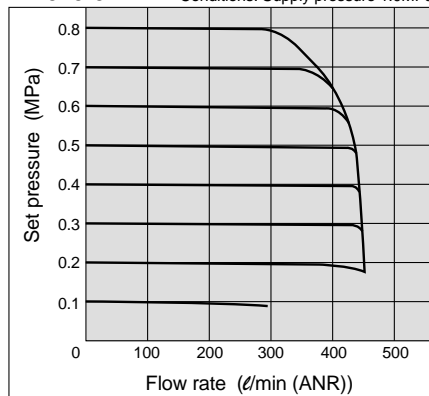

IR1020-01 Conditions: Back pressure 1.0MPa

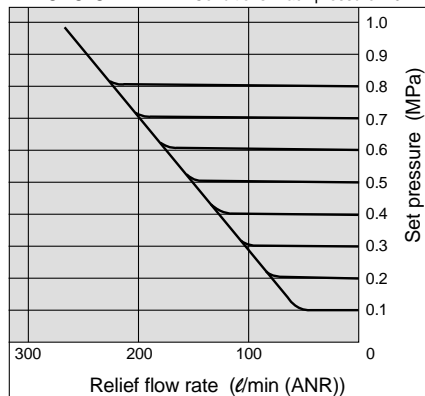

IR1020-01

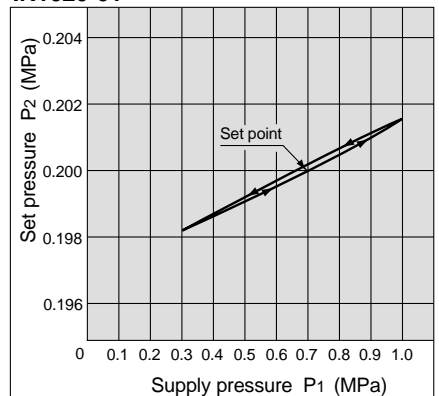

AC

AV

AU

AF

AR

IR

VEX

AW

AMR

AWM

AWD

ITV

VBA

VE

VY

G

AL

Series IR1000/2000/3000

Flow characteristics

* Testing methods conform to JIS B8372.

IR2000-02 Conditions: Supply pressure 0.5MPa

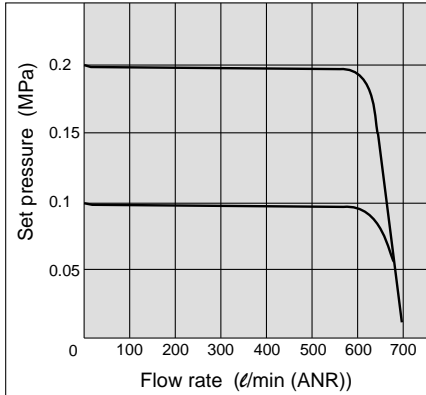

IR2010-02 Conditions: Supply pressure 0.7MPa

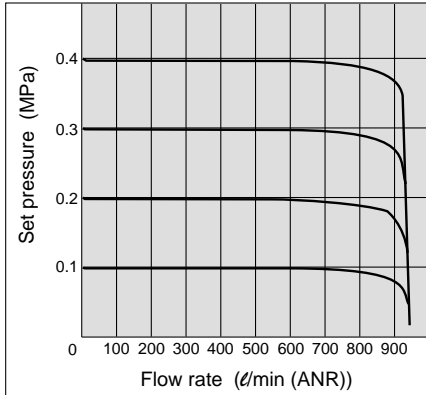

IR2020-02 Conditions: Supply pressure 1.0MPa

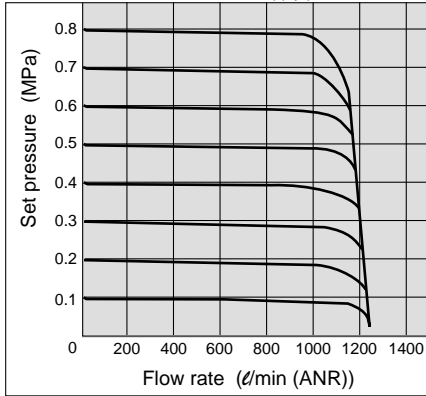

IR2120-02 Conditions: Supply pressure 1.0MPa

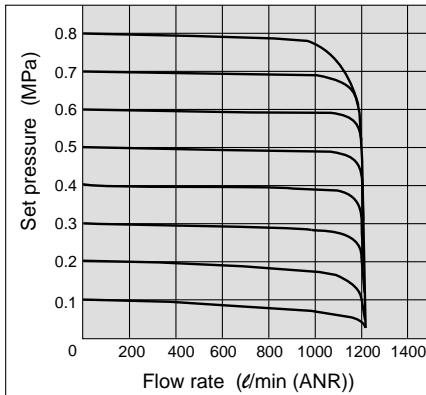

Relief characteristics

IR2000-02 Conditions: Back pressure 0.5MPa

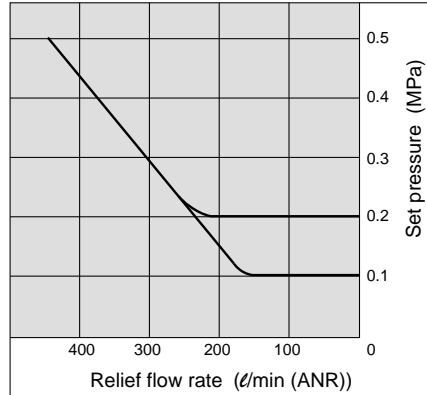

IR2010-02 Conditions: Back pressure 0.7MPa

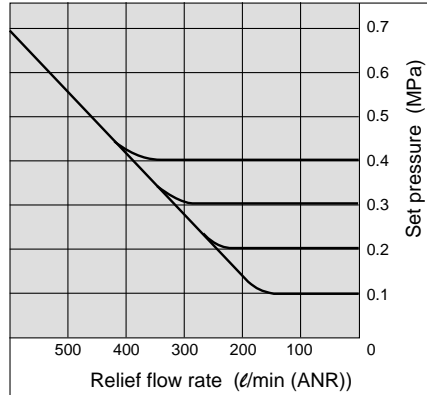

IR2020-02 Conditions: Back pressure 1.0MPa

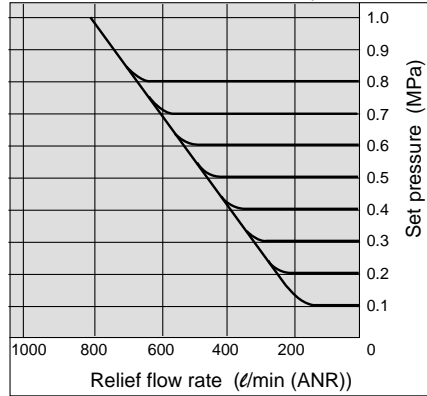

IR2120-02 Conditions: Back pressure 1.0MPa

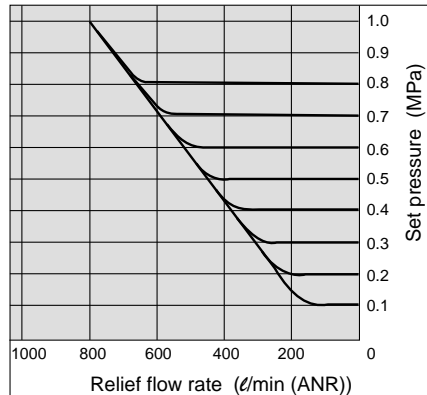

Pressure characteristics

Conditions: Supply pressure 0.7MPa
Set pressure 0.2MPa
Flow rate 0 l/min (ANR)

IR2000-02

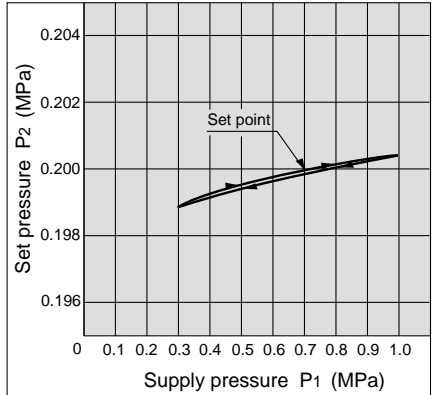

IR2010-02

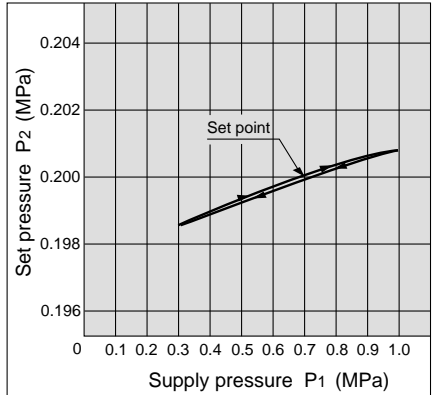

IR2020-02

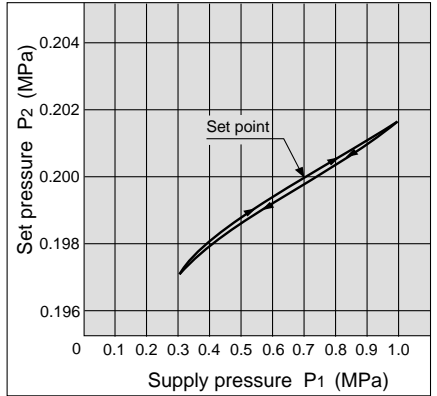

IR2120-02

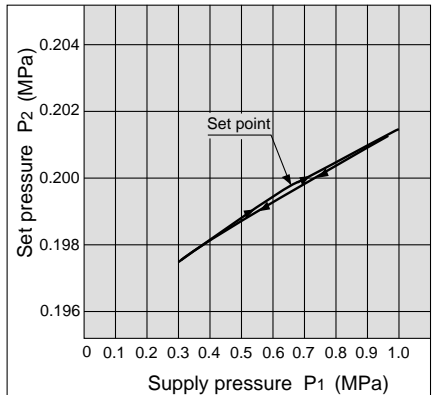

Series IR1000/2000/3000

Flow characteristics

* Testing methods conform to JIS B8372.

IR3000-03 Conditions: Supply pressure 0.5MPa

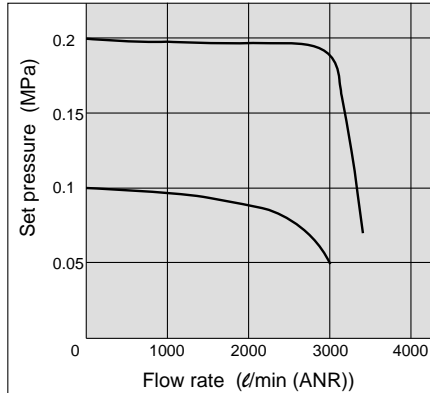

IR3010-03 Conditions: Supply pressure 0.7MPa

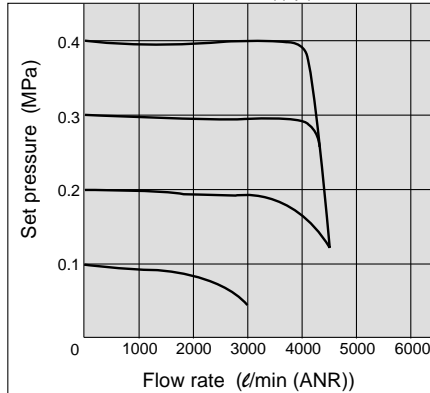

IR3020-03 Conditions: Supply pressure 1.0MPa

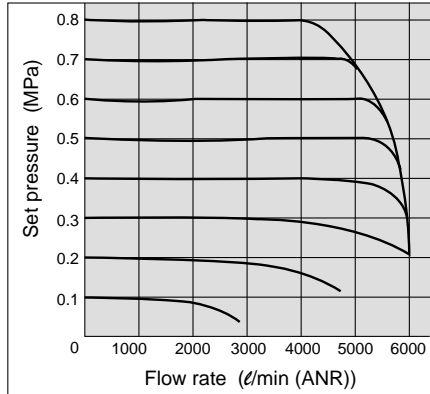

IR3120-03 Conditions: Supply pressure 1.0MPa

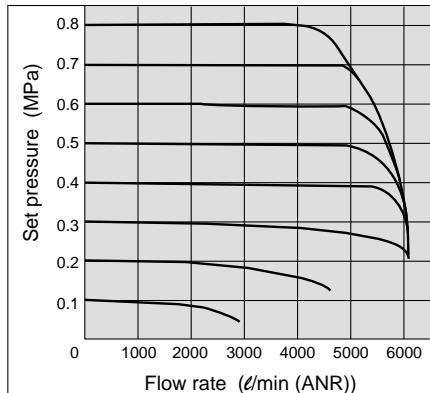

Relief characteristics

IR3000-03 Conditions: Back pressure 0.5MPa

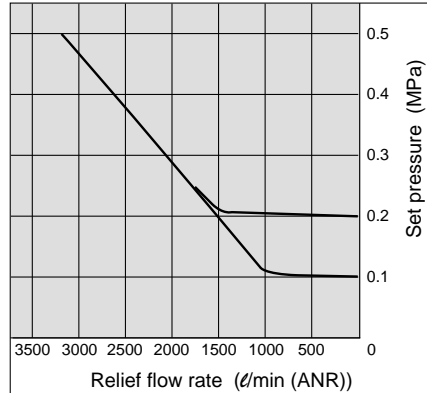

IR3010-03 Conditions: Back pressure 0.7MPa

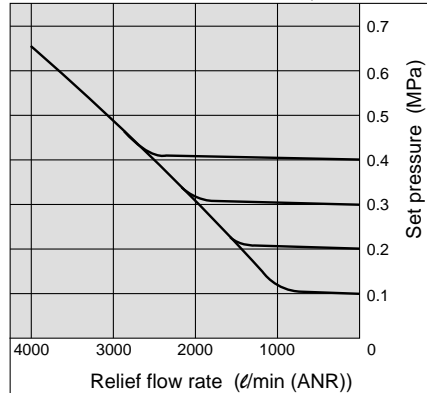

IR3020-03 Conditions: Back pressure 1.0MPa

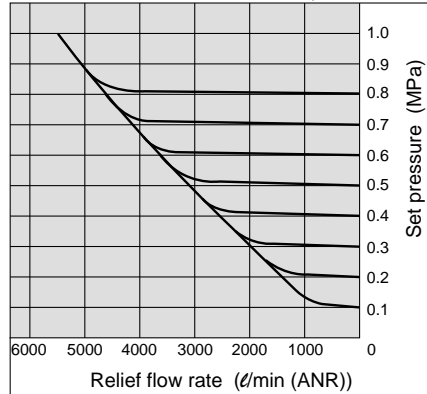

IR3120-03 Conditions: Back pressure 1.0MPa

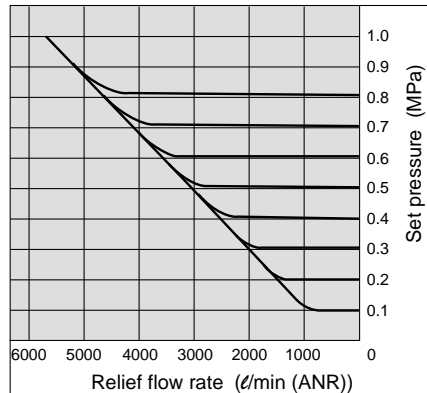

Pressure characteristics

Conditions: Supply pressure 0.7MPa
Set pressure 0.2MPa
Flow rate 0 l/min (ANR)

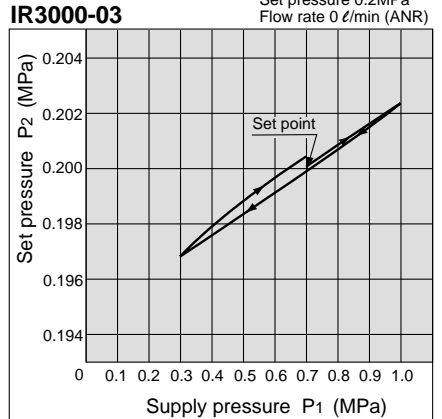

IR3010-03

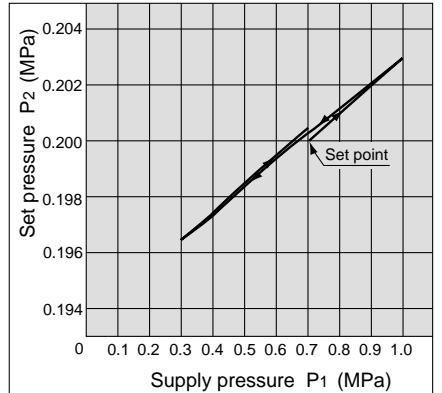

IR3020-03

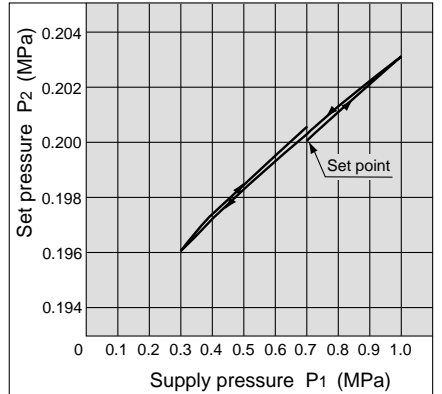

IR3120-03

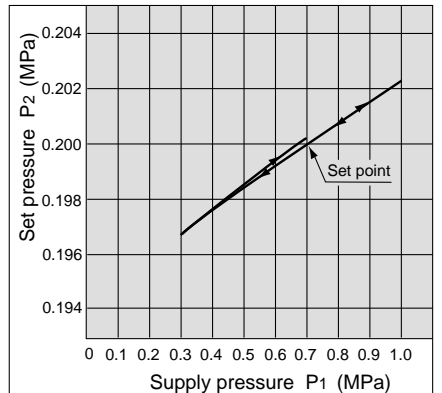

AC

AV

AU

AF

AR

IR

VEX

AW

AMR

AWM

AWD

ITV

VBA

VE

VY

G

AL

Series IR1000/2000/3000

Made to Order Specifications



Contact SMC for detailed dimensions, specifications and delivery times.

1 Clean Room

10 — Standard model number

Note) Contact SMC if equipped with pressure gauge.

● Clean room specifications

Specifications

Cleanliness	Class 10000
Bleed port	With M5 fitting (applicable tube O.D. ø6)
EXH port	IR1000/2000: M5 fitting (applicable tube O.D. ø6) IR3000: Rc(PT) 1/2 female thread
Grease	Teflon® grease

Teflon® is a registered trade mark of DuPont.

2 Copper-free

External and internal copper parts are changed to stainless steel or aluminum.

20 — Standard model number

Note) Contact SMC if equipped with pressure gauge.

● Copper-free specifications

3 Ozone Resistant

Fluoro rubber is used for rubber seal materials.

80 — Standard model number

● Ozone resistant specifications

4 For High and Low Temperature Environments

Standard model number — T

● For high/low temperature environments

T	For high temperature
L	For low temperature

Specifications

Symbol	T	L
Environment	For high temp. environments	For low temp. environments
Ambient temperature	-5 to 100°C (Max. 80°C with pressure gauge)	-30 to 60°C
Rubber material	Fluoro rubber	Special NBR or silicon rubber

5 Non-Grease

Assembly is performed in an ordinary environment without using grease. However, since parts are not washed, they are not completely oil-free.

Standard model number — X1

● Non-grease specifications

6 Manifold (except type IR2120 and series IR3000)

2 to 8 station manifold style regulators.
(Contact SMC regarding 9 or more stations.)

IRM 10 — 3 G —

● Set pressure and quantity

0	0.2MPa setting 1 to n pcs.
1	0.4MPa setting 1 to n pcs.
2	0.8MPa setting 1 to n pcs.

Example 1) 0.4MPa setting with 6 stations
IRM10-6G-16

Example 2) 0.2MPa setting 2 pcs.,
0.4MPa setting 2 pcs.,
0.8MPa setting 1 pc. with 5 stations
IRM20-5G-021221

● Accessory (pressure gauge)

—	None
G	IR1000: G33-□01 IR2000: G43-□01

● Stations

2	2 stations
⋮	⋮
8	8 stations

● Body size

10	IR1000
20	IR2000

● Manifold style regulator

Specifications

Stations	2 to 8 stations	
Ports	Common SUP	IR1000: Rc(PT) 1/4, IR2000: Rc(PT) 3/8
	Individual OUT	IR1000: Rc(PT) 1/8, IR2000: Rc(PT) 1/4
	Individual EXH (from IR body)	
Set pressure	0.2MPa, 0.4MPa and 0.8MPa settings can be combined	
Accessory (pressure gauge)	G33-□-01 (IR1000), G43-□-01 (IR2000)	

Note 1) Regulators to be manifolded are counted starting from station 1 on the left side with the OUT ports in front.

Note 2) When regulators with a different set pressure range are manifolded, viewing OUT ports from front the low pressure range is installed on the left side and the high pressure range is on the right side. In case of the "Example 2)" above mentioned, stations 1 and 2 are of 0.2MPa setting, stations 3 and 4 are of 0.4MPa setting, and station 5 is of 0.8MPa setting.

Note 3) Consult SMC when a blank plate is needed.



Series IR1000/2000/3000 Specific Product Precautions

Be sure to read before handling.

Refer to p.0-26 and 0-27 for Safety Instructions and common precautions on the products mentioned in this catalog.

Air Supply

⚠ Caution

1. If the supply pressure line contains drainage or dirt, etc., the fixed throttle can become clogged leading to malfunction, and therefore, in addition to an air filter (SMC Series AF) be sure to use a mist separator (SMC Series AM, AFM).

Refer to SMC's "Compressed Air Cleaning Systems" catalog regarding air quality.

2. Never use a lubricator on the supply side of the regulator, as this will positively cause the fixed throttle to become clogged and lead to malfunction. If lubrication is required for terminal devices, connect a lubricator on the output side of the regulator.

Maintenance

⚠ Warning

1. When the valve guide (refer to construction drawing on p.1.6-6) is to be removed during maintenance, first reduce the set pressure to "0" and completely shut off the supply pressure.
2. When a pressure gauge is to be mounted, remove the plug after reducing the set pressure to "0".

Precautions for IR10□0 only

⚠ Warning

1. When remounting the valve guide after removing it for maintenance, use a tightening torque of no more than 0.6Nm. Since the valve guide on this product is made of resin, there is a danger of damage if tightened with a torque exceeding the prescribed value.

Operation

⚠ Caution

1. Do not use a precision regulator outside the range of its specifications as this can cause failure. (Refer to specifications.)
2. When mounting is performed, make connections while confirming port indications.

Operation

⚠ Caution

3. If a directional switching valve (solenoid valve, mechanical valve, etc.) is mounted on the supply side of the regulator and repeatedly switched ON and OFF, wear of the nozzle/flapper section will be accelerated and a discrepancy in the setting value may occur. Therefore, avoid using a directional switching valve on the supply side. In the event a directional switching valve will be used, install it on the output side of the regulator.
4. Air is normally discharged from the bleed port (the hole on the side of the body's mid-section). This is a necessary consumption of air based on the construction of the precision regulator, and is not an abnormality.
5. Be sure to tighten the lock nut after pressure adjustment.

Precautions for IR30□0, IR3120 only

⚠ Caution

1. The supply pressure is relatively high (approx. 0.5MPa or more), the set pressure is low (approx. 0.1MPa or less), and when operated with the output side released to the atmosphere, there may be pulsations in the setting side pressure. In this kind of situation, operate with the supply pressure reduced as much as possible, or increase the set pressure somewhat and restrict the output line (add and adjust a stop valve, etc.).
2. The capacity of the output side is large, and when used for the purpose of a relief function, the exhaust sound will be loud when being relieved. Therefore, operate with a silencer (SMC Series AN) mounted on the exhaust port (EXH port). The connection is Rc(PT) 1/2.

Precautions for IR2120, IR3120 (air operated style) only

⚠ Caution

1. Since the output of types IR2120 and IR3120 is the same pressure as the input signal pressure, select a type of regulator (general purpose or precision type) for input signal pressure adjustment according to the application.
2. The screw on the topmost section is a zero point adjustment screw which is locked at the factory and requires no adjustment for operation.

AC

AV

AU

AF

AR

IR

VEX

AW

AMR

AWM

AWD

ITV

VBA

VE

VY

G

AL



Series IR1000/2000/3000 Precision Regulator Precautions

Be sure to read before handling.

Refer to p.0-26 and 0-27 for Safety Instructions and common precautions on the products mentioned in this catalog.

Piping

Warning

1. Screw piping together with the recommended proper torque while holding the side with female threads.

Looseness or faulty sealing will occur if tightening torque is insufficient, while thread damage will result if the torque is excessive. Furthermore, if the side with the female threads is not held while tightening, excessive force will be applied directly to piping brackets, etc. causing damage or other problems.

Recommended proper torque Nm

Connection thread	1/8	1/4	3/8	1/2
Torque	7 to 9	12 to 14	22 to 24	28 to 30

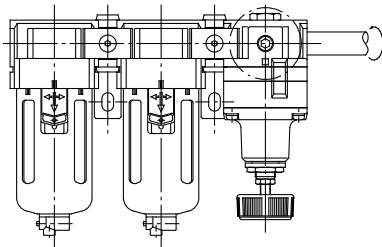

2. Do not allow twisting or bending moment to be applied other than the weight of the equipment itself.

Provide separate support for external piping, as damage may otherwise occur.

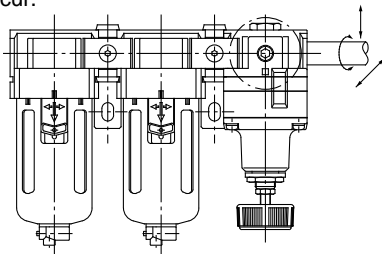

3. Since excessive moment loads and the propagation of vibrations, etc. can easily result from inflexible piping made of steel, etc., avoid these problems by using flexible tubing for intermediate connections.

Piping

Caution

1. Preparation before piping

Before piping is connected, it should be thoroughly blown out with air (flushing) or washed to remove cutting chips, cutting oil and other debris from inside the pipe.

2. Wrapping of pipe tape

When connecting pipes and fittings, etc., be sure that cutting chips from the pipe threads and sealing material do not get inside.

Further, when pipe tape is used, leave 1.5 to 2 thread ridges exposed at the end of the pipe/fitting.

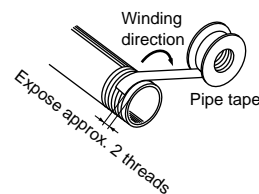

Operating Environment

Warning

1. Do not operate in locations having an atmosphere of corrosive gases, chemicals, sea water, water or steam, or where there will be contact with the same.
2. Do not operate in locations where vibration or impact occurs.
3. In locations which receive direct sunlight, provide a protective cover, etc.
4. In locations near heat sources, block off any radiated heat.
5. In locations where there is contact with spatter from water, oil or solder, etc., implement suitable protective measures.

Air Supply

Warning

1. These products are designed for use with compressed air. Contact SMC if any other fluid will be used.
2. Do not use compressed air which includes chemicals, synthetic oils containing organic solvents, salt, or corrosive gases, etc., as this can cause damage or malfunction.
3. If drainage is not removed from air filters and mist separators, it can flow out to the downstream side and lead to the malfunction of pneumatic equipment.

In cases where the management of drainage removal will be difficult, the use of filters with auto drains is recommended.