

Standard Type Series MHZ2

How to Order

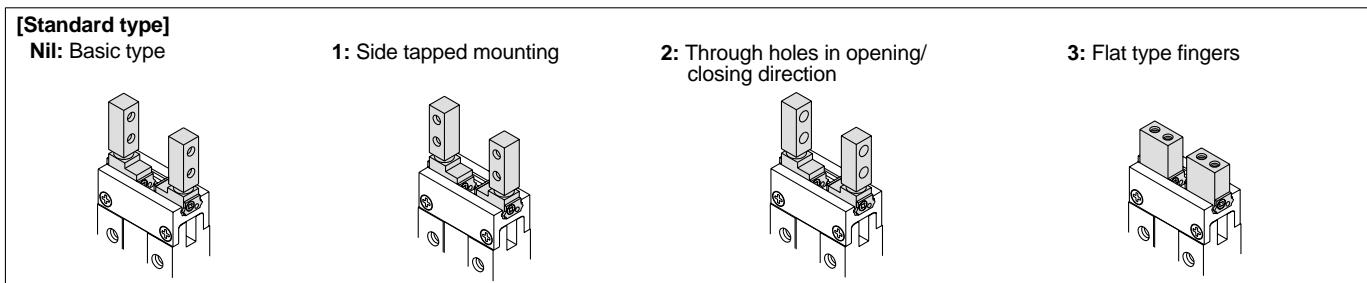
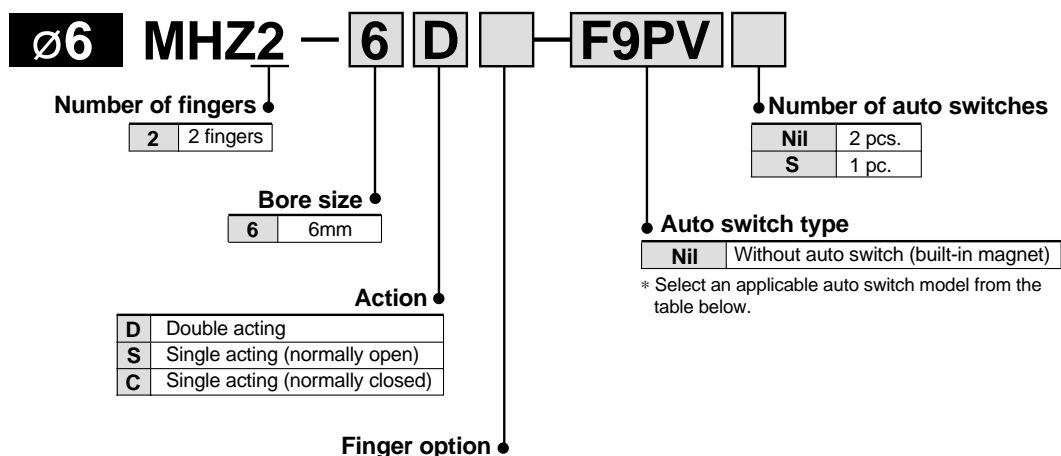

Applicable auto switches/* Refer to pages 48 through 60 for detailed auto switch specifications.

Type	Special function	Electrical entry	Indicator light	Wiring (output)	Load voltage		Auto switch part no.		Lead wire length (m)*				Applicable load		
					DC	AC	Electrical entry direction		0.5 (Nil)	3 (L)	5 (Z)	Flexible lead wire (-61)			
							Perpendicular	In-line							
Solid state switch	—	Grommet	Yes	3 wire (NPN)	24V	12V	—	F9NV	F9N	●	●	—	○	—	Relay, PLC
				3 wire (PNP)				F8N	—	●	●	○	○		
				2 wire				F9PV	F9P	●	●	—	○		
				F8P				—	●	●	○	○			
				F9BV				F9B	●	●	—	○			
F8B	—	●	●	○	○										

* Lead wire length symbols: 0.5m Nil (Example) F9N
3m L (Example) F9NL
5m Z (Example) F9NZ

* Auto switches marked with a "○" symbol are produced upon receipt of order.

Note 1) When using a D-F8□ switch, mount it at a distance of 10mm or more from magnetic substances such as iron, etc.

Note 2) Add "-61" at the end of the part number for the flexible lead wire.

(Examples)

When ordering with an air gripper

MHZ□ 2-16D-F9NVS-61

● Flexible lead wire

When ordering auto switches only

D-F9PL-61

● Flexible lead wire

How to Order

ø10 to ø25 MHZ2 - 16 D - - - F9PV - - -

Number of fingers

2	2 fingers
---	-----------

Bore size

10	10mm
16	16mm
20	20mm
25	25mm

Action

D	Double acting
S	Single acting (normally open)
C	Single acting (normally closed)

Number of auto switches

Nil	2 pcs.
S	1 pc.

Auto switch type

Nil	Without auto switch (built-in magnet)
-----	---------------------------------------

* Select an auto switch model from the table below.

Finger position/Option

Body option

Standard type
[MHQG2 compatible type]
Nil: Basic type

1: Side tapped mounting

2: Through holes in opening/closing direction

3: Flat type fingers

The flat type fingers do not have standard and narrow options. When MHQG2/MHQ2 compatible types are required, see the -X51 order made specifications on page 63.

Narrow type
[MHQ2 compatible type]
N: Basic type

N1: Side tapped mounting

N2: Through holes in opening/closing direction

Nil: Basic type

E: End boss type
Side ported (double acting/single acting)

W: End boss type
Axial port with ø4
One-touch fitting for coaxial tubing (double acting)

K: End boss type
Axial port with ø4
One-touch fitting (single acting)

M: End boss type
Axial M5 port (single acting)

Applicable auto switches/* Refer to pages 48 through 60 for detailed auto switch specifications.

Type	Special function	Electrical entry	Indicator light	Wiring (output)	Load voltage		Auto switch part no.		Lead wire length (m)*			Applicable load	Applicable model						
					DC	AC	Electrical entry direction	In-line	0.5 (Nil)	3 (L)	5 (Z)		Flexible lead wire (-61)	ø10	ø16	ø20	ø25		
Solid state auto switch	—	Grommet	Yes	3 wire (NPN)	24V	—	Perpendicular	Y69A	Y59A	●	●	○	Standard	IC circuit	●	●	●	●	
								F9NV	F9N	●	●	—	○	—	—	●	●	●	●
								F8N	—	●	●	○	○	—	—	●	●	●	●
								Y7PV	Y7P	●	●	○	Standard	IC circuit	●	●	●	●	●
								F9PV	F9P	●	●	—	○	—	—	●	●	●	●
								F8P	—	●	●	○	○	—	—	●	●	●	●
				Y69B	Y59B	●	●	○	○	—	—	●	●	●	●				
				F9BV	F9B	●	●	—	○	—	—	●	●	●	●				
				F8B	—	●	●	○	○	—	—	●	●	●	●				
				Y7NWV	Y7NW	●	●	○	Standard	IC circuit	—	—	●	●	—	—			
				F9NWV	F9NW	●	●	○	○	—	—	—	●	●	—	—			
				Y7PWV	Y7PW	●	●	○	Standard	IC circuit	—	—	●	●	—	—			
	F9PWV	F9PW	●	●	○	○	—	—	—	●	●	—	—						
	Y7BWV	Y7BW	●	●	○	Standard	—	—	—	●	●	—	—						
F9BWV	F9BW	●	●	○	○	—	—	—	●	●	—	—							

* Lead wire length symbols: 0.5m Nil (Example) F9N
3m L (Example) F9NL
5m Z (Example) Y59AZ

Note 2) Add "-61" at the end of the part number for the flexible lead wire.

(Examples)

When ordering with an air gripper

MHZ 2-16D-F9NVS- 61

Flexible lead wire ●

When ordering auto switches only

D-F9PL- 61

Flexible lead wire ●

Note 1) Use caution regarding hysteresis in the 2 color indicator types. When using this type, refer to "Auto Switch Hysteresis" on page 56.

Note 3) Through hole mounting is not possible when using auto switch types D-Y59, D-Y69, or D-Y7.

How to Order

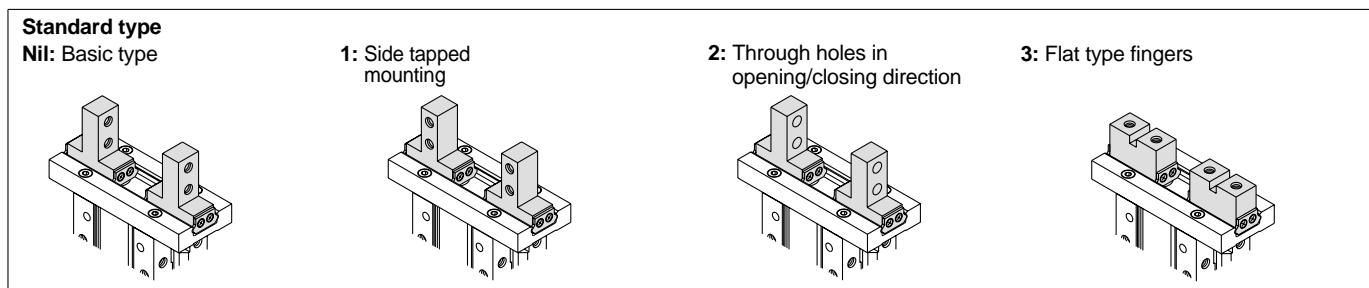
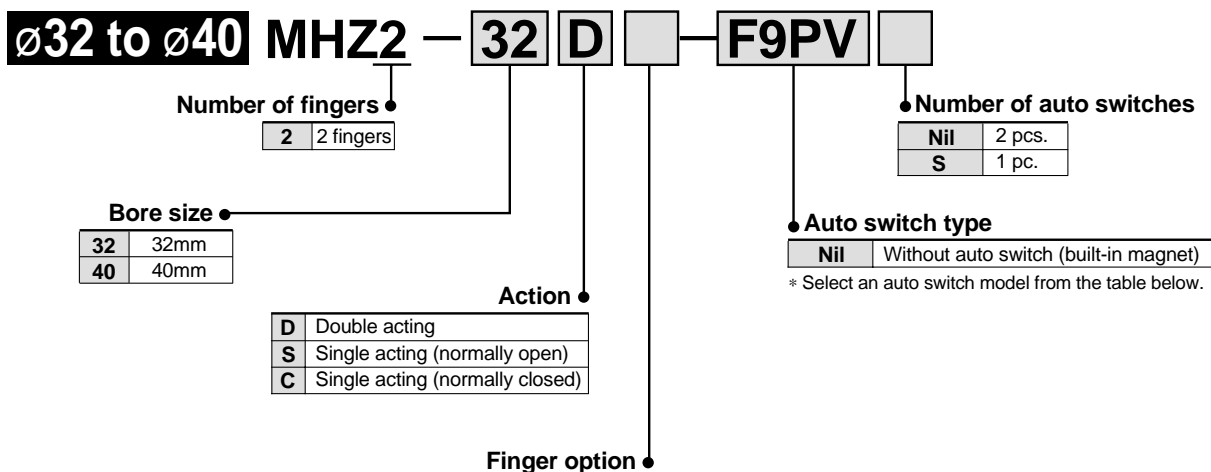

Applicable auto switches/* Refer to pages 48 through 60 for detailed auto switch specifications.

Type	Special function	Electrical entry	Indicator light	Wiring (output)	Load voltage		Auto switch part no.		Lead wire length (m)*			Applicable load	Applicable model						
					DC	AC	Electrical entry direction		0.5 (Nil)	3 (L)	5 (Z)		Flexible lead wire (-61)	ø32	ø40				
							Perpendicular	In-line											
Solid state auto switch	—	Grommet	Yes	3 wire (NPN)	5V, 12V	—	Y69A	Y59A	●	●	○	Standard	IC circuit	●	●				
							F9NV	F9N	●	●	—			○	—	●	●		
				3 wire (PNP)	5V, 12V	—	Y7PV	Y7P	●	●	○	Standard	IC circuit	●	●				
							F9PV	F9P	●	●	—			○	—	●	●		
				2 wire	12V	—	Y69B	Y59B	●	●	○	—	Relay, PLC	●	●				
							F9BV	F9B	●	●	—			○	—	●	●		
				Diagnostic indication (2 color indicator)	—	—	—	3 wire (NPN)	5V, 12V	—	Y7NWV	Y7NW	●	●	○	Standard	IC circuit	●	●
											F9NWV	F9NW	●	●	○			○	—
								3 wire (PNP)	5V, 12V	—	Y7PWV	Y7PW	●	●	○	Standard	IC circuit	●	●
											F9PWV	F9PW	●	●	○			○	—
	2 wire	12V	—	Y7BWV	Y7BW	●	●	○	Standard	—	●	●							
				F9BWV	F9BW	●	●	○			○	—	●	●					

* Lead wire length symbols: 0.5m Nil (Example) F9N
3m L (Example) F9NL
5m Z (Example) Y59AZ

* Auto switches marked with a "○" symbol are produced upon receipt of order.

Note 1) Use caution regarding hysteresis in the 2 color indicator types. When using this type, refer to "Auto Switch Hysteresis" on page 56.

Note 2) Add "-61" at the end of the part number for the flexible lead wire.

(Examples)

When ordering with an air gripper

MHZ□2-16D-F9NVS-□61

● Flexible lead wire

When ordering auto switches only

D-F9PL-□61

● Flexible lead wire

Note 3) Through hole mounting is not available when using auto switch types D-Y59, D-Y69, or D-Y7.

Series MHZ2

ø6



ø10 to ø25



ø32, ø40



Symbols:

Double acting type

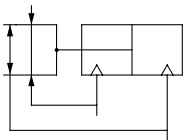

Single acting type, normally open

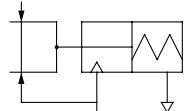

Single acting type, normally closed

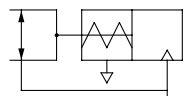

Specifications

Fluid		Air	
Operating pressure	Double acting	ø6: 0.15 to 0.7MPa ø10: 0.2 to 0.7MPa ø16 to ø40: 0.1 to 0.7MPa	
	Single acting	Normally open	ø6: 0.3 to 0.7MPa ø10: 0.35 to 0.7MPa ø16 to ø40: 0.25 to 0.7MPa
		Normally closed	ø6: 0.3 to 0.7MPa ø10: 0.35 to 0.7MPa ø16 to ø40: 0.25 to 0.7MPa
Ambient and fluid temperature		-10 to 60°C	
Repeatability		ø6 to ø25: ±0.01mm ø32, ø40: ±0.02mm	
Maximum operating frequency		ø6 to ø25: 180c.p.m. ø32, ø40: 60c.p.m.	
Lubrication		Non-lube	
Action		Double acting, Single acting	
Auto switch (option) ^{Note}		Solid state switch (3 wire, 2 wire)	

Note) Refer to pages 48 through 60 for details regarding auto switch specifications.

Models

Action	Model	Bore size (mm)	Gripping force ^{Note 1)}		Opening/Closing stroke (both sides) mm	Weight ^{Note 2)} g	
			Gripping force per finger Effective value N				
			External gripping force	Internal gripping force			
Double acting	MHZ2-6D	6	3.3	6.1	4	27	
	MHZ2-10D(N)	10	11	17	4	55	
	MHZ2-16D(N)	16	34	45	6	115	
	MHZ2-20D(N)	20	42	66	10	235	
	MHZ2-25D(N)	25	65	104	14	430	
	MHZ2-32D	32	158	193	22	715	
	MHZ2-40D	40	254	318	30	1275	
Single acting	Normally open	MHZ2-6S	6	1.9	—	4	27
		MHZ2-10S(N)	10	7.1		4	55
		MHZ2-16S(N)	16	27		6	115
		MHZ2-20S(N)	20	33		10	240
		MHZ2-25D(N)	25	45		14	435
		MHZ2-32S	32	131		22	760
		MHZ2-40S	40	217		30	1370
	Normally closed	MHZ2-6C	6	—	3.7	4	27
		MHZ2-10C(N)	10		13	4	55
		MHZ2-16C(N)	16		38	6	115
		MHZ2-20C(N)	20		57	10	240
		MHZ2-25C(N)	25		83	14	430
		MHZ2-32C	32		161	22	760
		MHZ2-40C	40		267	30	1370

Note 1) Values based on pressure of 0.5MPa, gripping point L = 20mm, at center of stroke.

Note 2) Values excluding weight of auto switch.

Options

• Body options/End boss type

Symbol	Piping port position	Type of piping port							Applicable model	
		MHZ2-6	MHZ2-10	MHZ2-16	MHZ2-20	MHZ2-25	MHZ2-32	MHZ2-40	Double acting	Single acting
Nil	Basic type	M3 x 0.5	M5 x 0.8				—		●	●
E	Side ported	—	M3 x 0.5	M5 x 0.8		—		●	●	
W	Axial port	—	With ø4 One-touch fitting for coaxial tube			—		●	—	
K	Axial port	—	With ø4 One-touch fitting			—		—	●	
M	Axial port	—	M5 x 0.8				—		—	●

* For detailed body option specifications, refer to option specifications on page 25.

Clean Room Series: Air Gripper

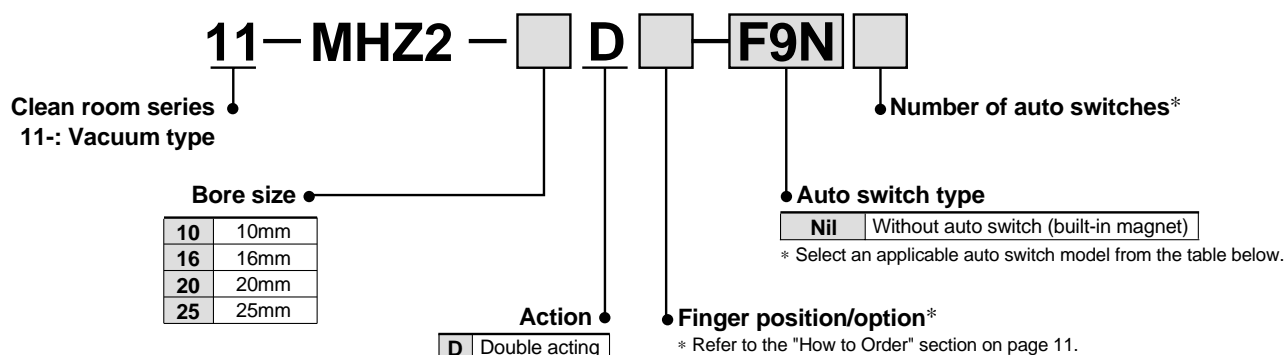

Applicable auto switches/* Refer to pages 48 through 60 for detailed auto switch specifications

Type	Special function	Electrical entry	Indicator light	Wiring (output)	Load voltage		Auto switch part no.		Lead wire length (m)*			Applicable load		
					DC	AC	Electrical entry direction		0.5 (Nil)	3 (L)	5 (Z)		Flexible lead wire (-61)	
							Perpendicular	In-line						
Solid state switch	—	Grommet	Yes	3 wire (NPN)	24V	12V	—	F9NV	F9N	●	●	—	○	Relay, PLC
				3 wire (PNP)				F9PV	F9P	●	●	—	○	
				2 wire				F9BV	F9B	●	●	—	○	
								F8N	—	●	●	○	○	
								F8P	—	●	●	○	○	
								F8B	—	●	●	○	○	

* Lead wire length symbols: 0.5m Nil (Example) F9N
3m L (Example) F9NL
5m Z (Example) F9NZ

* Auto switches marked with a "O" symbol are produced upon receipt of order.

Note 1) When using a D-F8□ switch, mount it at a distance of 10mm or more from magnetic substances such as iron, etc.

Note 2) Add "-61" at the end of the part number for the flexible lead wire.

(Examples)

When ordering with an air gripper

MHZ 2-16D-F9NVS-61

When ordering auto switches only

D-F9PL-61

● Flexible lead wire

● Flexible lead wire

Specifications

Fluid	Air
Operating pressure	ø10: 0.2 to 0.7MPa ø16 to ø25: 0.1 to 0.7MPa
Ambient and fluid temperature	-10 to 60°C
Repeatability	±0.01mm
Maximum operating frequency	180c.p.m.
Lubrication	Non-lube
Action	Double acting
Particulate generation grade	Grade 2
Auto switch (option)	Solid state switch (3 wire, 2 wire)

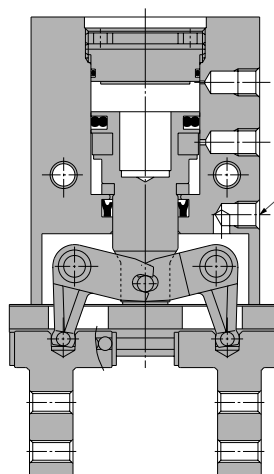

Relief port

The concentrated vacuuming of internally generated particulates prevents them from spreading into the clean room.

For details, refer to SMC Information "Clean Series: Air Gripper Series 11-MHZ2" (98-E461).

Series MHZ2

Construction/MHZ2-6□

Double acting/with fingers open

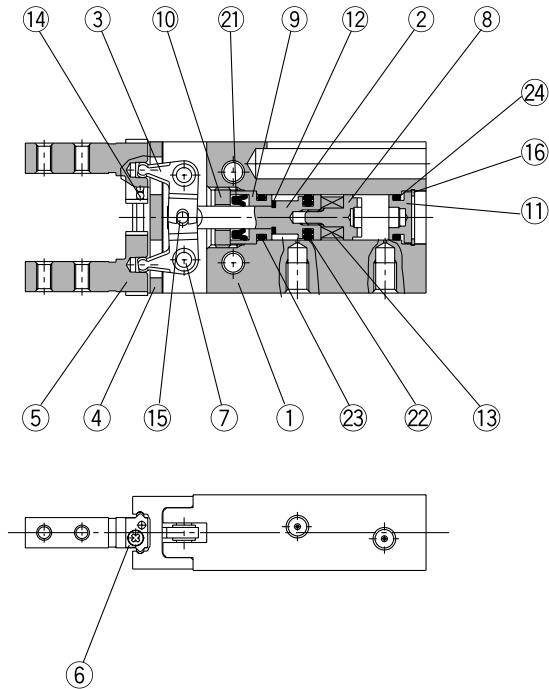

Double acting/with fingers closed

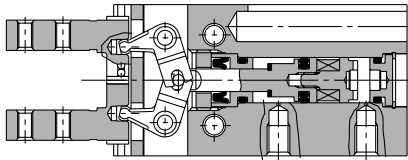

Single acting/normally open

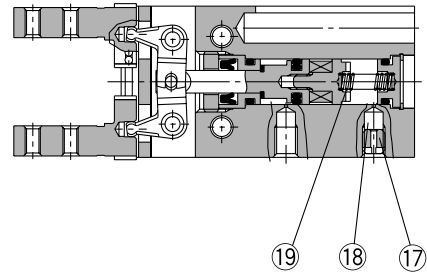

Single acting/normally closed

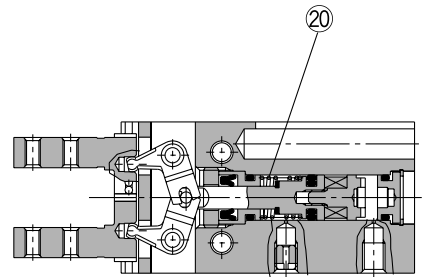

Parts list

No.	Description	Material	Note
1	Body	Aluminum alloy	Hard anodized
2	Piston	Stainless steel	
3	Lever	Stainless steel	Heat treated
4	Guide	Stainless steel	Heat treated
5	Finger	Stainless steel	Heat treated
6	Roller stopper	Stainless steel	
7	Lever shaft	Stainless steel	Nitrided
8	Magnet holder	Stainless steel	
9	Holder	Brass	Electroless nickel plated
10	Holder lock	Stainless steel	
11	Cap	Aluminum alloy	Clear anodized
12	Bumper	Urethane rubber	
13	Magnet	Rare earth magnet	Nickel plated

Parts list

No.	Description	Material	Note
14	Steel balls	High carbon chromium bearing steel	
15	Needle roller	High carbon chromium bearing steel	
16	C type snap ring	Carbon steel	Nickel plated
17	Exhaust plug	Brass	Electroless nickel plated
18	Exhaust filter	Polyvinyl formal	
19	N.O. spring	Stainless steel spring wire	
20	N.C. spring	Stainless steel spring wire	
21	Rod seal	NBR	
22	Piston seal	NBR	
23	Gasket	NBR	
24	Gasket	NBR	

Replacement parts: Seal kits

Seal kit no.	Description
MHZ6-PS	Kit includes items 21, 22, 23 and 24 from the table above.

* Seal kits consist of items 21, 22, 23 and 24 in one kit, and can be ordered using the seal kit number.

Note) Contact SMC when replacing seals.

Construction/MHZ2-10□ to 40□

Double acting/with fingers open

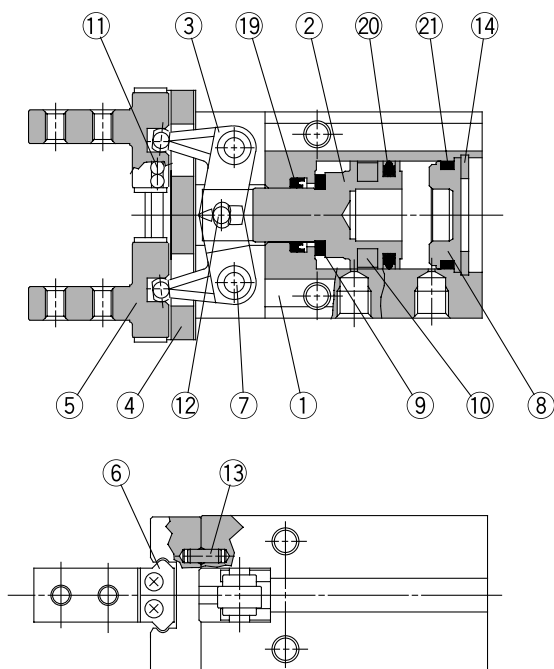

Single acting/normally open

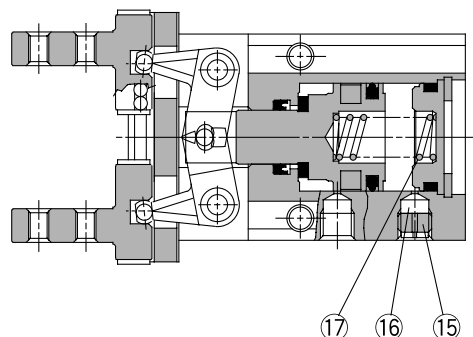

Single acting/normally closed

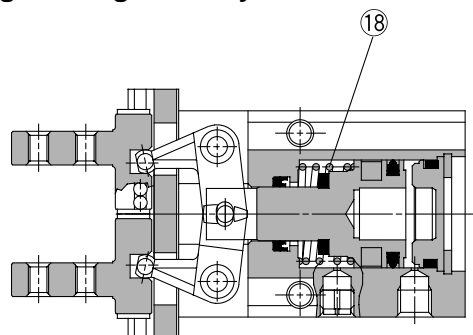

Double acting/with fingers closed

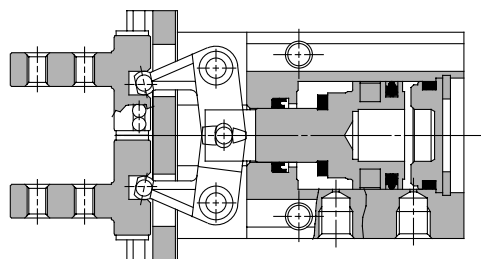

Parts list

No.	Description	Material	Note
1	Body	Aluminum alloy	Hard anodized
2	Piston	ø10, ø16: Stainless steel ø20 to ø40: Aluminum alloy	ø20 to ø40: Hard anodized
3	Lever	Stainless steel	Heat treated
4	Guide	Stainless steel	Heat treated
5	Finger	Stainless steel	Heat treated
6	Roller stopper	Stainless steel	
7	Lever shaft	Stainless steel	Nitrided
8	Cap	ø10 to ø25: Synthetic resin ø32, ø40: Aluminum alloy	ø32, ø40: Clear anodized
9	Bumper	Urethane rubber	
10	Rubber magnet	Synthetic rubber	

Parts list

No.	Description	Material	Note
11	Steel balls	High carbon chromium bearing steel	
12	Needle roller	High carbon chromium bearing steel	
13	Parallel pin	Stainless steel	
14	C type snap ring	Carbon steel	Nickel plated
15	Exhaust plug A	Brass	Electroless nickel plated
16	Exhaust filter A	Polyvinyl formal	
17	N.O. spring	Stainless steel spring wire	
18	N.C. spring	Stainless steel spring wire	
19	Rod seal	NBR	
20	Piston seal	NBR	
21	Gasket	NBR	

Replacement parts: Seal kits

Seal kit no.						Description
MHZ2-10D	MHZ2-16D	MHZ2-20D	MHZ2-25D	MHZ2-32D	MHZ2-40D	Kits include items 19, 20 and 21 from the table above.
MHZ10-PS	MHZ16-PS	MHZ20-PS	MHZ25-PS	MHZ32-PS	MHZ40-PS	

* Seal kits consist of items 19, 20 and 21 in one kit, and can be ordered using the seal kit number for each cylinder bore size.

Series MHZ2

Dimensions

Scale: 100%

MHZ2-6□

Double acting/Single acting

Basic type

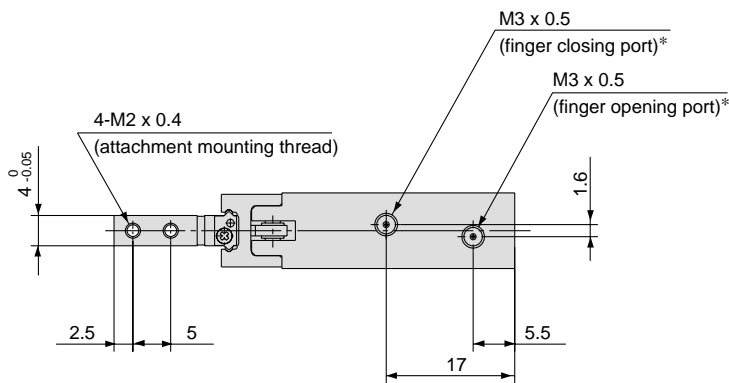
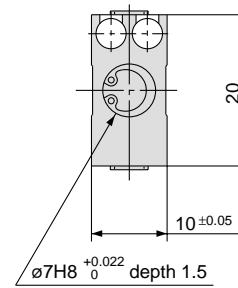
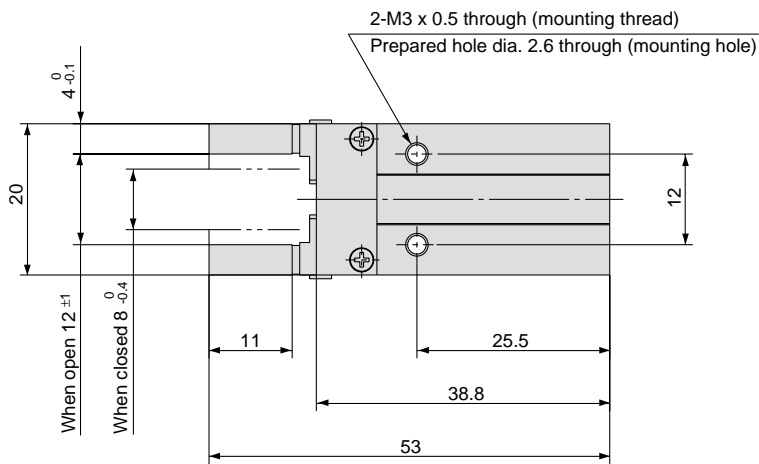
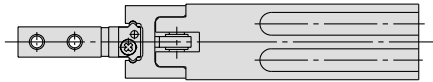

* For single action, the port on one side is a breathing hole.

Auto switch mounting groove dimensions

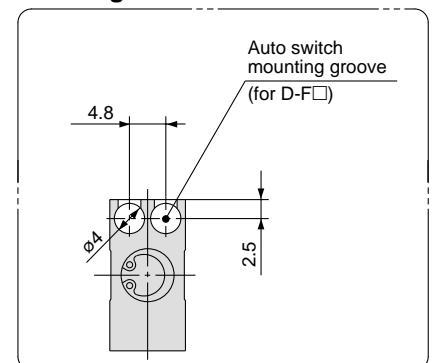

Scale: 90%

MHZ2-10□
Double acting/Single acting
Basic type

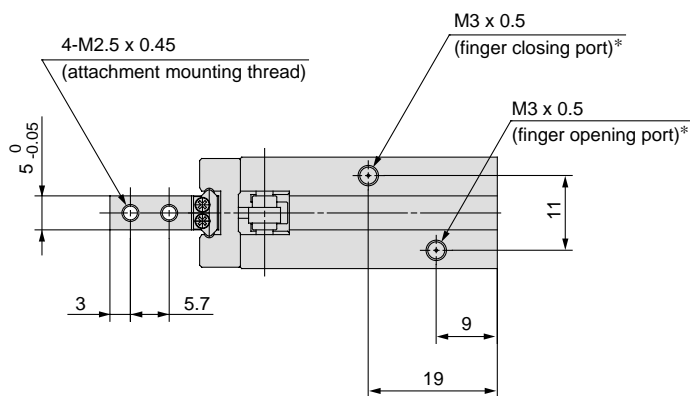
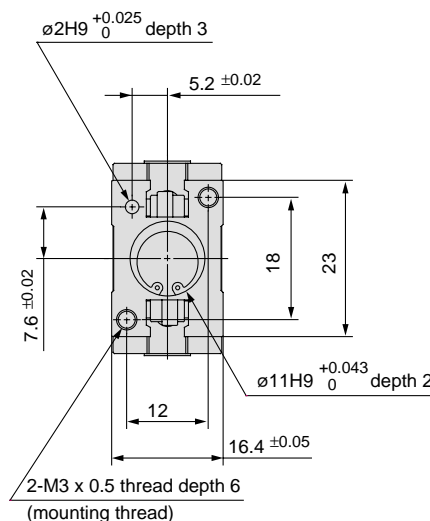
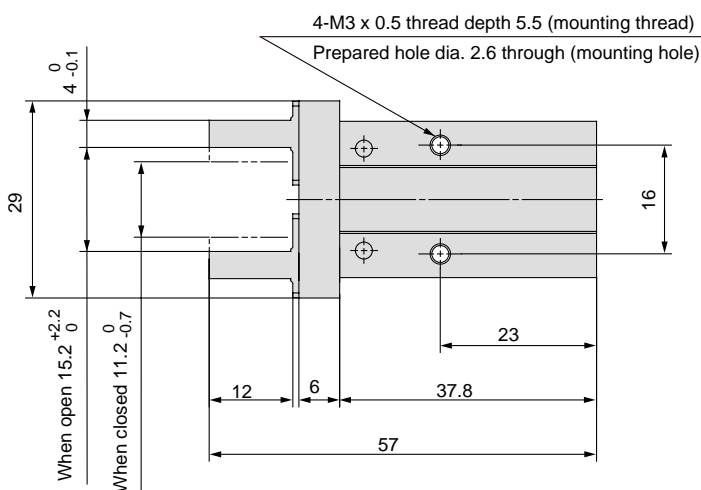
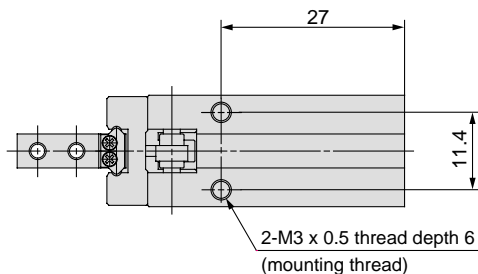

* For single action, the port on one side is a breathing hole.

Finger position/Narrow type

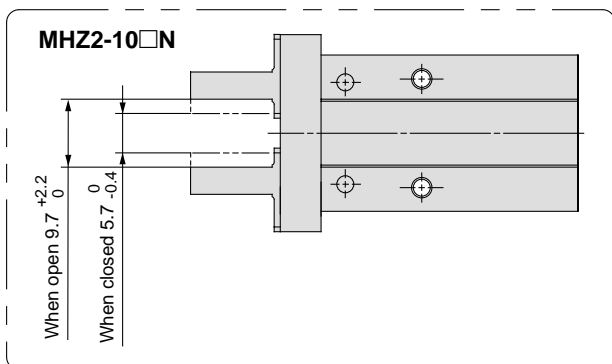

Auto switch mounting groove dimensions

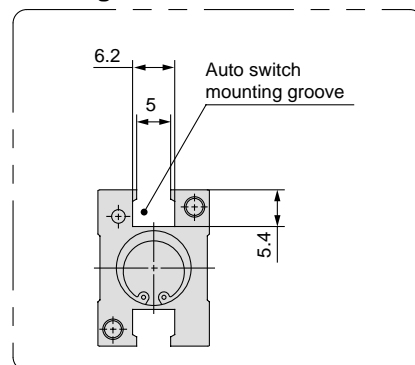

Note) When using D-Y59, D-Y69 and D-Y7 type auto switches, through hole mounting is not possible.

Series MHZ2

Dimensions

MHZ2-16□

Double acting/Single acting
Basic type

Scale: 65%

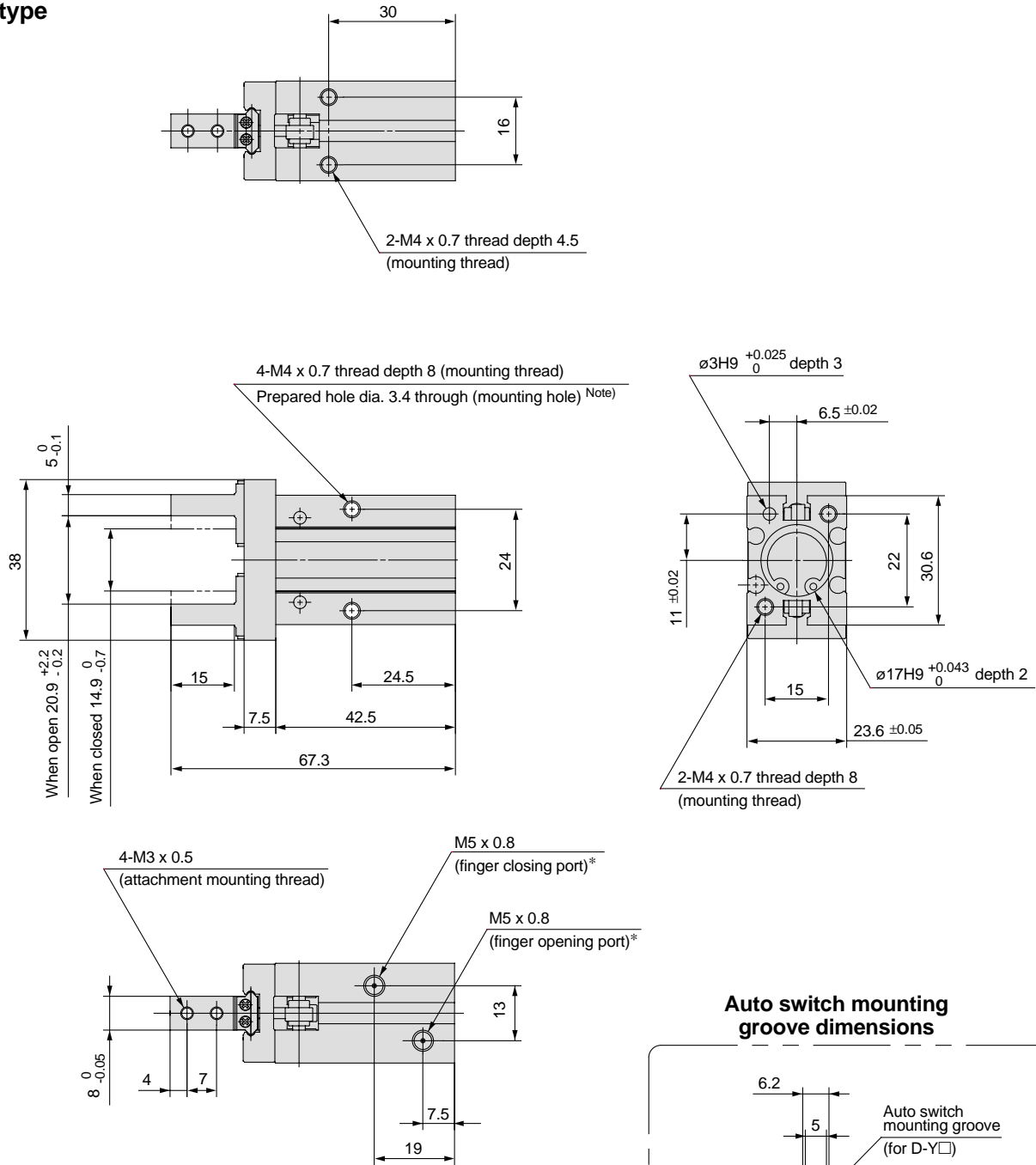

* For single action, the port on one side is a breathing hole.

Finger position/Narrow type

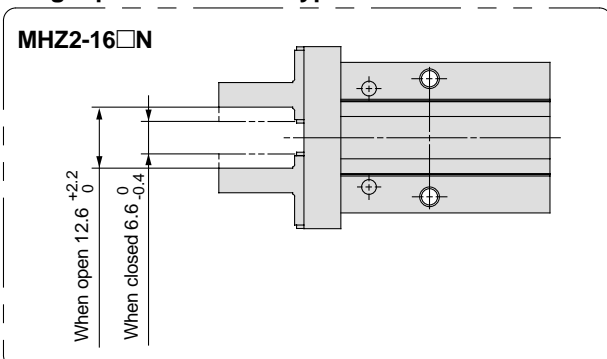

Auto switch mounting groove dimensions

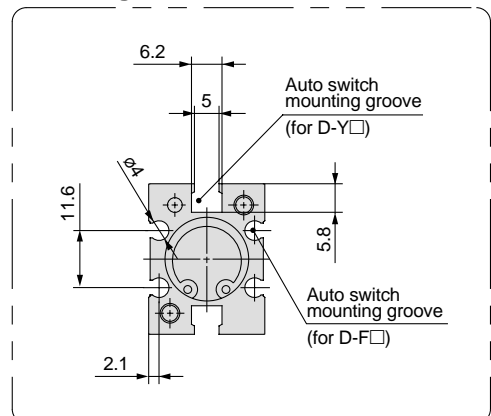

Note) When using D-Y59, D-Y69 and D-Y7 type auto switches, through hole mounting is not possible.

Scale: 60%

MHZ2-20□

Double acting/Single acting
Basic type

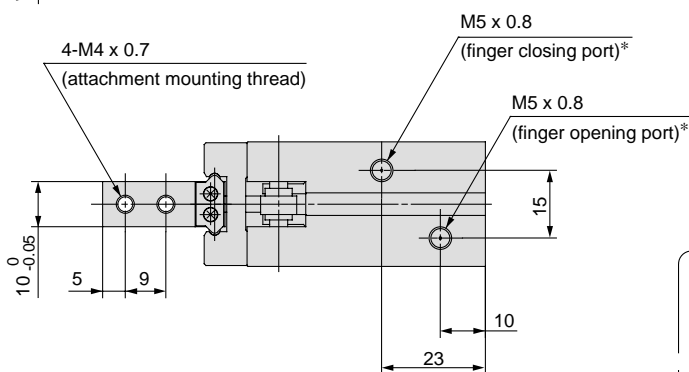
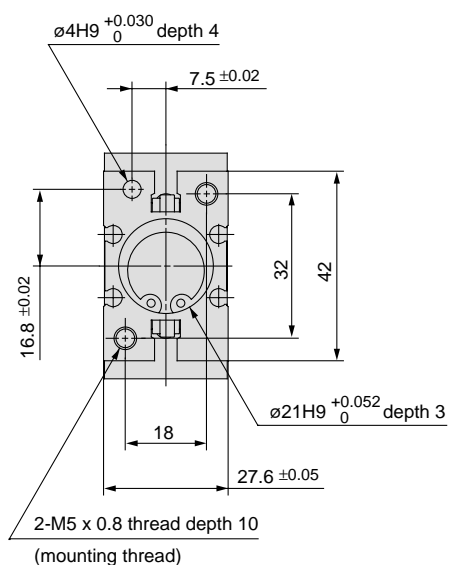
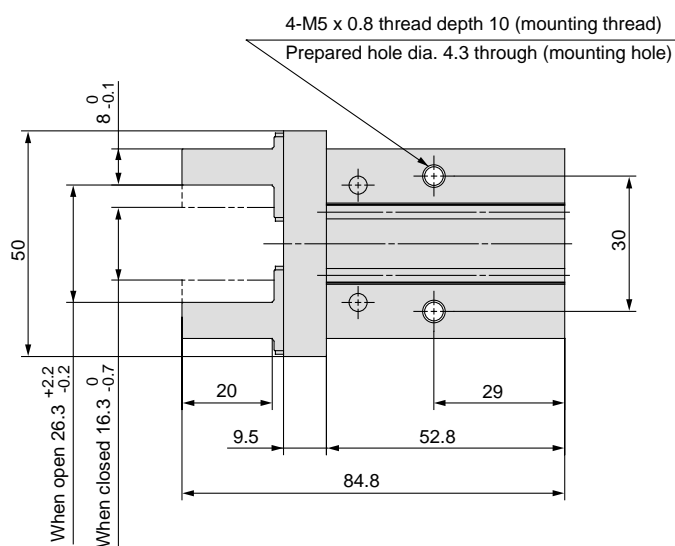
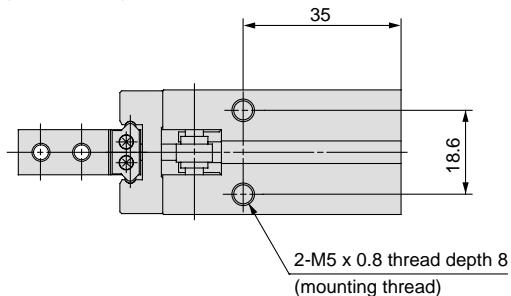

* For single action, the port on one side is a breathing hole.

Finger position/Narrow type

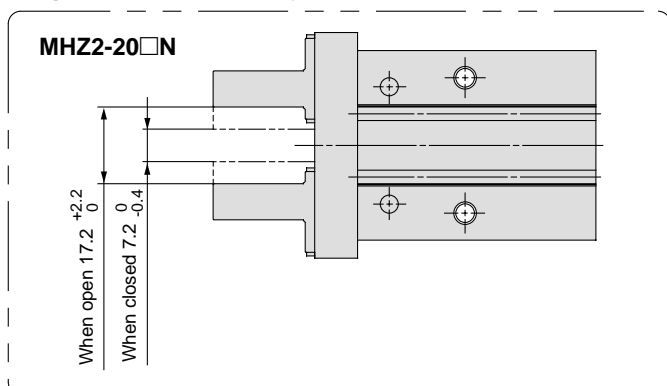

Auto switch mounting groove dimensions

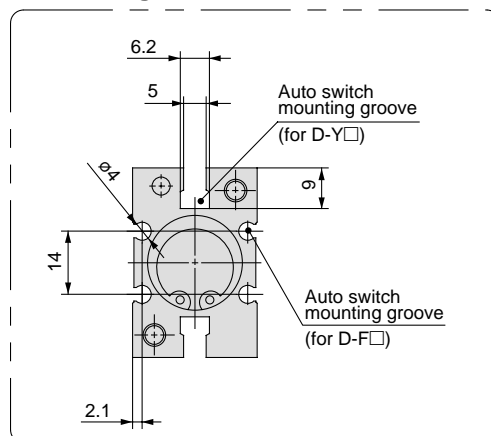

Note) When using D-Y59, D-Y69 and D-Y7 type auto switches, through hole mounting is not possible.

Series MHZ2

Dimensions

MHZ2-25□

Double acting/Single acting

Basic type

Scale: 50%

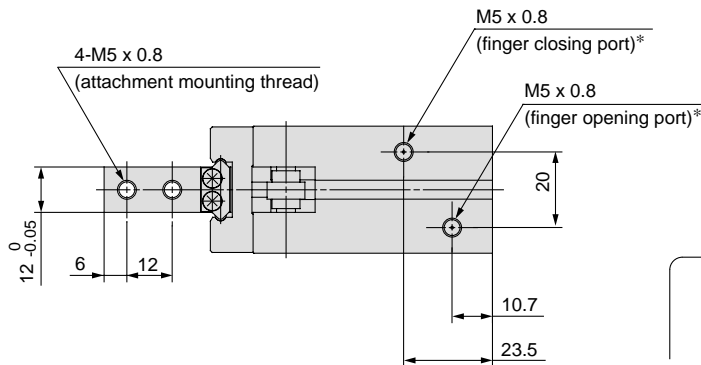
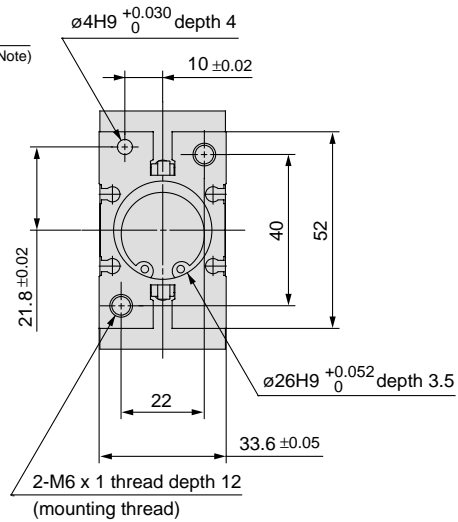
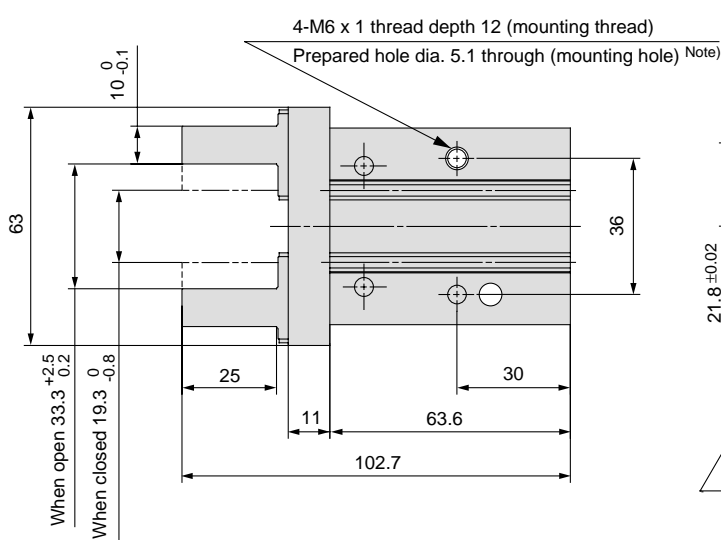
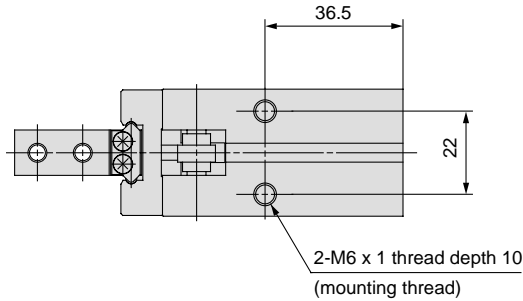

* For single action, the port on one side is a breathing hole.

Auto switch mounting groove dimensions

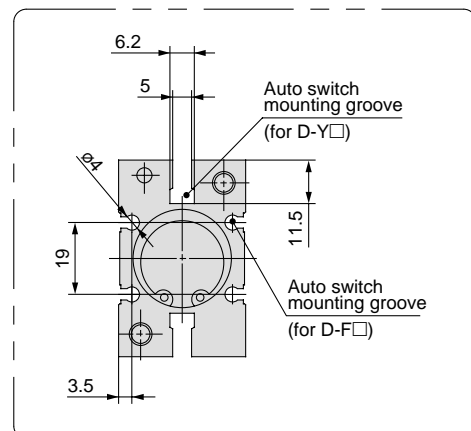

Note) When using D-Y59, D-Y69 and D-Y7 type auto switches, through hole mounting is not possible.

Finger position/Narrow type

MHZ2-25□N

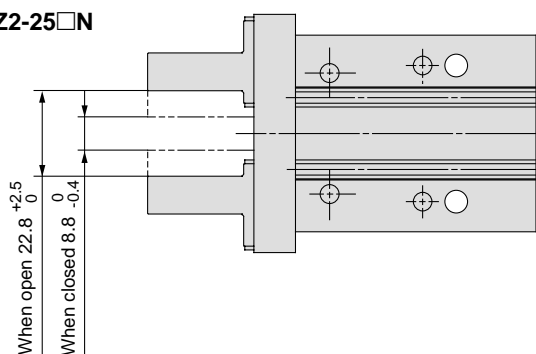

Scale: 40%

MHZ2-32□
Double acting/Single acting
Basic Type

The values inside () are dimensions for the single acting type.

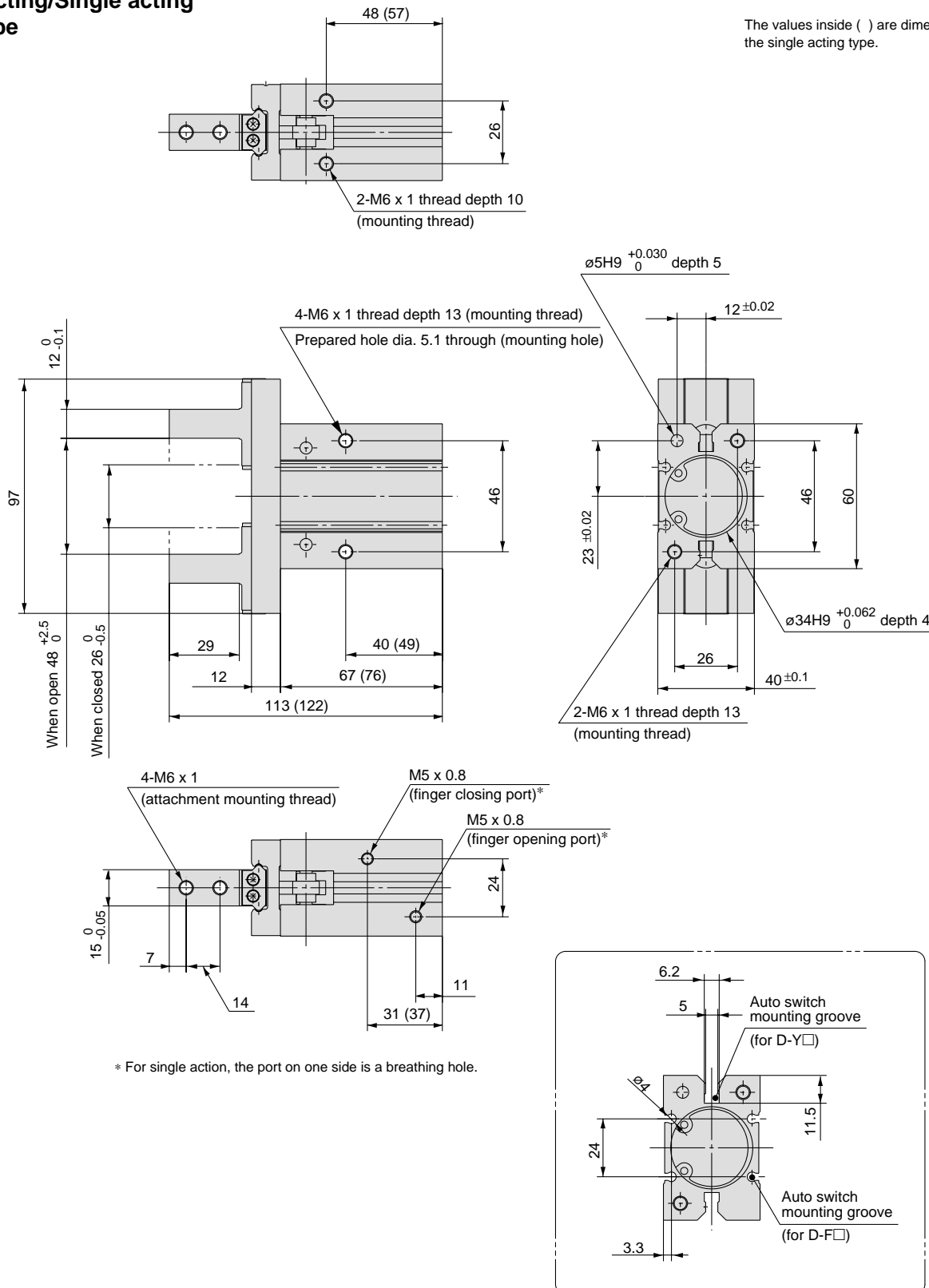

* For single action, the port on one side is a breathing hole.

Note) When using D-Y59, D-Y69 and D-Y7 type auto switches, through hole mounting is not possible.

Series MHZ2

Dimensions

MHZ2-40□

Double acting/Single acting
Basic type

Scale: 40%

The values inside () are dimensions for the single acting type.

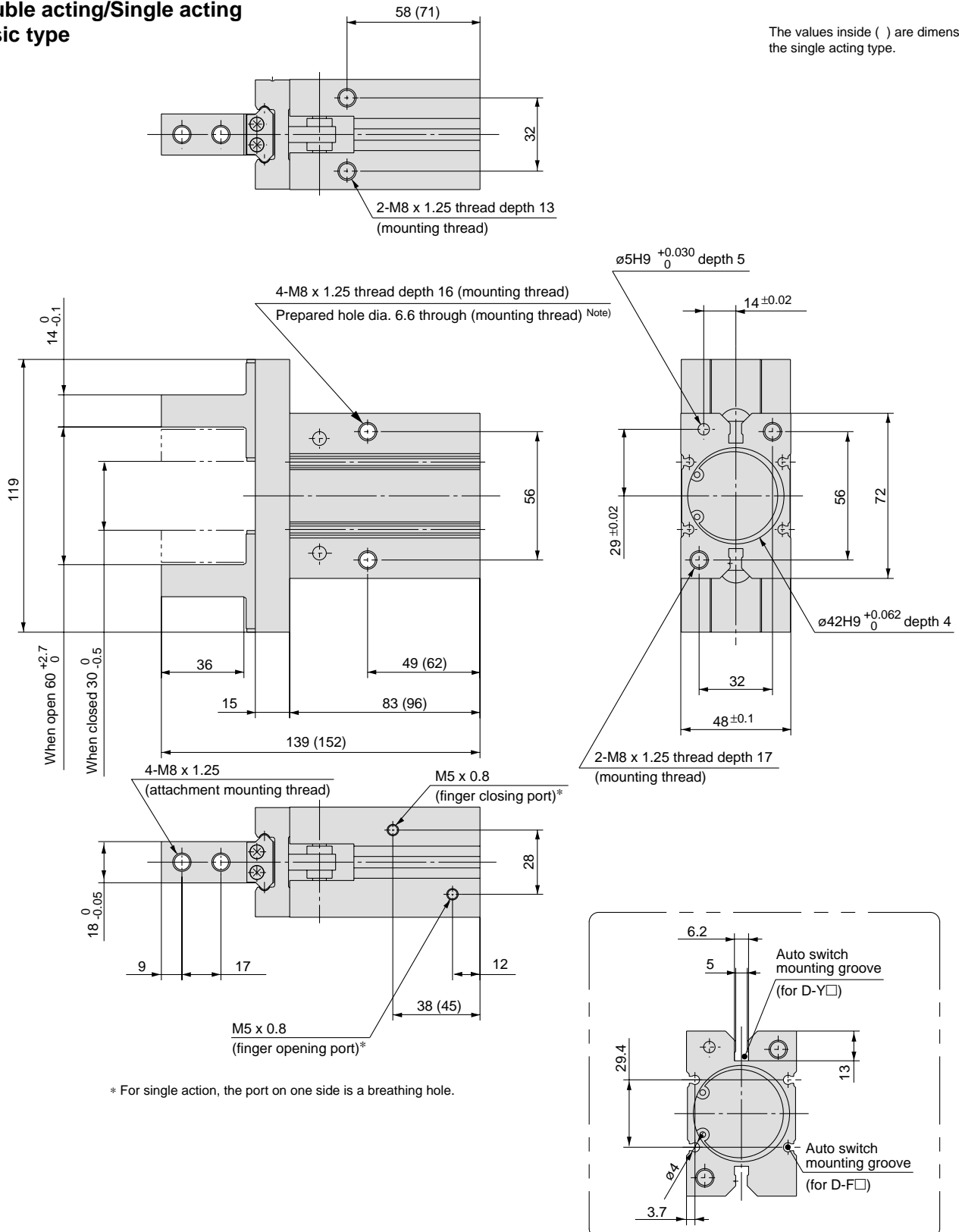

* For single action, the port on one side is a breathing hole.

Note) When using D-Y59, D-Y69 and D-Y7 type auto switches, through hole mounting is not possible.

Standard Type/Series MHZ2 Finger Options

Side Tapped Mounting [1/N1]

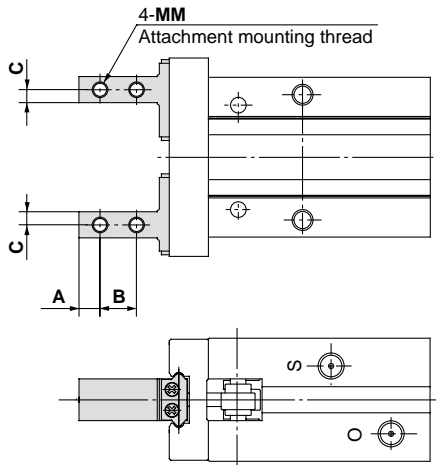

Unit: mm

Model	A	B	C	MM
MHZ2- 6□1	2.5	5	2	M2 x 0.4
MHZ2-10□ ¹ _{N1} □	3	5.7	2	M2.5 x 0.45
MHZ2-16□ ¹ _{N1} □	4	7	2.5	M3 x 0.5
MHZ2-20□ ¹ _{N1} □	5	9	4	M4 x 0.7
MHZ2-25□ ¹ _{N1} □	6	12	5	M5 x 0.8
MHZ2-32□1□	7	14	6	M6 x 1
MHZ2-40□1□	9	17	7	M8 x 1.25

* Specifications and dimensions other than the above are the same as the basic type (including narrow type).

Through Holes in Opening/Closing Direction [2/N2]

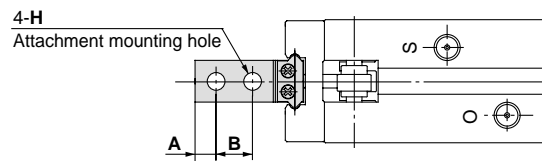
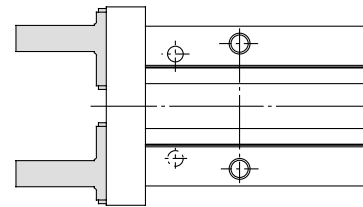

Unit: mm

Model	A	B	H
MHZ2- 6□2	2.5	5	2.4
MHZ2-10□ ² _{N2} □	3	5.7	2.9
MHZ2-16□ ² _{N2} □	4	7	3.4
MHZ2-20□ ² _{N2} □	5	9	4.5
MHZ2-25□ ² _{N2} □	6	12	5.5
MHZ2-32□2□	7	14	6.6
MHZ2-40□2□	9	17	9

* Specifications and dimensions other than the above are the same as the basic type (including narrow type).

Flat Type Fingers [3]

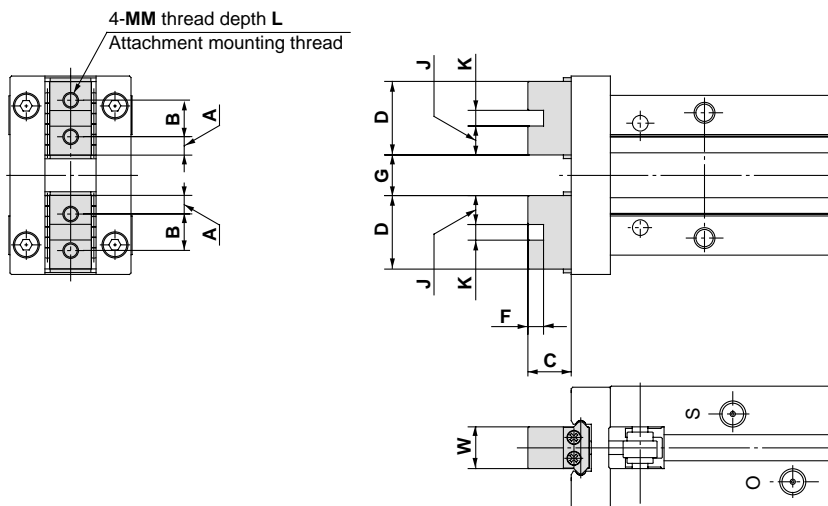

Unit: mm

Model	A	B	C	D	F	G		J	K	MM	L	W	Weight g
						Open	Closed						
MHZ2- 6□3 *1)	2	3.5	7.2	7.5	—	5 ^{+1.2} _{-0.8}	1 ^{+0.2} ₀	—	—	M2 x 0.4	3	4 ⁰ _{-0.05}	26
MHZ2-10□3□ *2), *3)	2.45	6	5.2	10.9	2	5.4 ^{+2.2} ₀	1.4 ⁰ _{-0.2}	4.45	2H9 ^{+0.025} ₀	M2.5 x 0.45	5	5 ⁰ _{-0.05}	55
MHZ2-16□3□ *2), *3)	3.05	8	8.3	14.1	2.5	7.4 ^{+2.2} ₀	1.4 ⁰ _{-0.2}	5.8	2.5H9 ^{+0.025} ₀	M3 x 0.5	6	8 ⁰ _{-0.05}	115
MHZ2-20□3□ *2), *3)	3.95	10	10.5	17.9	3	11.6 ^{+2.3} ₀	1.6 ⁰ _{-0.2}	7.45	3H9 ^{+0.025} ₀	M4 x 0.7	8	10 ⁰ _{-0.05}	235
MHZ2-25□3□ *2), *3)	4.9	12	13.1	21.8	4	16 ^{+2.5} ₀	2 ⁰ _{-0.2}	8.9	4H9 ^{+0.030} ₀	M5 x 0.8	10	12 ⁰ _{-0.05}	420
MHZ2-32□3□	7.3	20	18	34.6	5	25 ^{+2.7} ₀	3 ⁰ _{-0.2}	14.8	5H9 ^{+0.030} ₀	M6 x 1	12	15 ⁰ _{-0.05}	740 (785) *4)
MHZ2-40□3□	8.7	24	22	41.4	6	33 ^{+2.9} ₀	3 ⁰ _{-0.2}	17.7	6H9 ^{+0.030} ₀	M8 x 1.25	16	18 ⁰ _{-0.05}	1335 (1430) *4)

*1) To mount attachments, use M2 hexagon socket head cap screws with ø3.3 top diameter, or JISB1101 type M2 round head screws.

*2) Specifications and dimensions other than the above are the same as the basic type (including narrow type).

*3) The overall length is the same as the MHQ(G) flat finger type.

*4) The values inside () are for the single acting type.

Compact Series
MHZA2-6/MHZA2J2-6

Standard Type
MHZ2

Long Stroke
MHZL2

With Dust Cover
MHZJ2

Auto Switches

Order Made

Model Selection

Precautions

Standard Type/Series MHZ2

Body Options: End Boss Type

Applicable Models

Symbol	Piping port position	Type of Piping Port				Applicable model		
		MHZ2-10	MHZ2-16	MHZ2-20	MHZ2-25	Double acting	Single acting	
						Normally open	Normally closed	
E	Side ported	M3 x 0.5	M5 x 0.8		●	●	●	
W	Axial port	With ø4 One-touch fitting for coaxial tube				●	—	—
K		With ø4 One-touch fitting				—	●	●
M		M5 x 0.8				—	●	●

Side Ported [E]

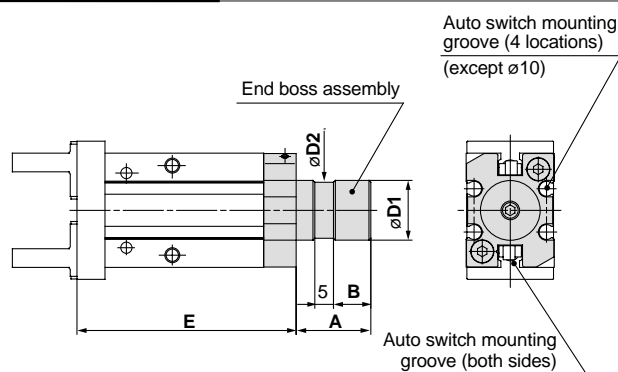

Unit: mm

Model	A	B	D1	D2	E
MHZ2-10□□	15	7	12f8 ^{-0.016} _{-0.043}	11	52.8
MHZ2-16□□	20	10	16f8 ^{-0.016} _{-0.043}	15	58.7
MHZ2-20□□	22	12	20f8 ^{-0.020} _{-0.053}	19	70.5
MHZ2-25□□	25	15	25f8 ^{-0.020} _{-0.053}	24	82.9

Other dimensions and specifications correspond to the standard type.

- * Refer to the dimension table.
- * When auto switches are used, side mounting with through holes is not possible.

Axial Port (One-Touch Fitting for Coaxial Tubing) [W]

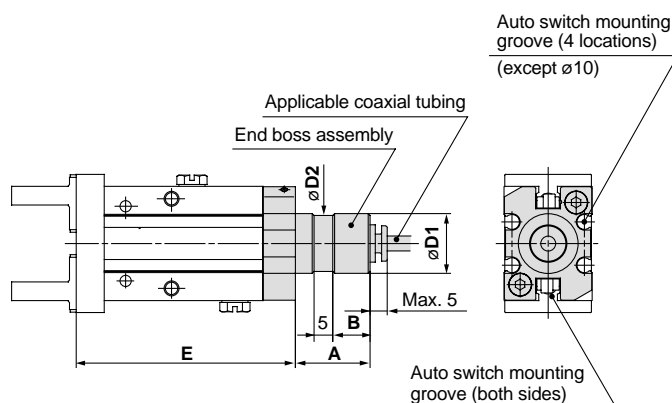

Unit: mm

Model	A	B	D1	D2	E
MHZ2-10□□	15	7	12f8 ^{-0.016} _{-0.043}	11	52.8
MHZ2-16□□	20	10	16f8 ^{-0.016} _{-0.043}	15	58.7
MHZ2-20□□	22	12	20f8 ^{-0.020} _{-0.053}	19	70.5
MHZ2-25□□	25	15	25f8 ^{-0.020} _{-0.053}	24	82.9

Other dimensions and specifications correspond to the standard type.

Applicable coaxial tubing

Reference symbol

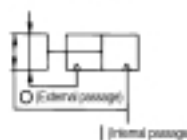

Specification	Model	TW04B-20
Outside diameter		4mm
Max. operating pressure		0.6MPa
Min. bending radius		10mm
Operating temperature		-20 to 60°C
Material		Nylon 12

- * Refer to the dimension table.
- * When auto switches are used, side mounting with through holes is not possible.

Changing from Coaxial to Single Tubing

Changing to single tubing is possible by using a branch "Y" or branch tee fitting. In this case particularly, single tube fittings and tubing for ø3.2 will be necessary.

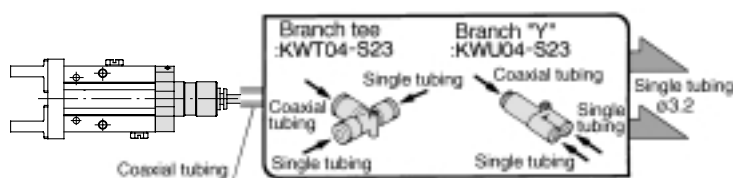

Branch tee, Different diameter tee, Branch "Y", Male run tee

Refer to catalog CAT.E004-A "Coaxial Air Tubing System" regarding coaxial tubing.

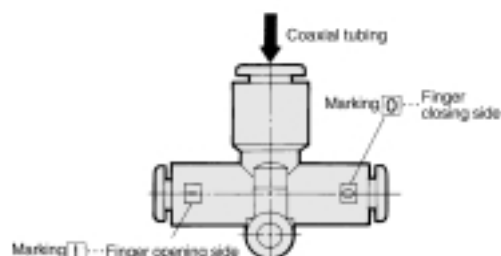

Axial Port (with One-touch Fitting) [K]

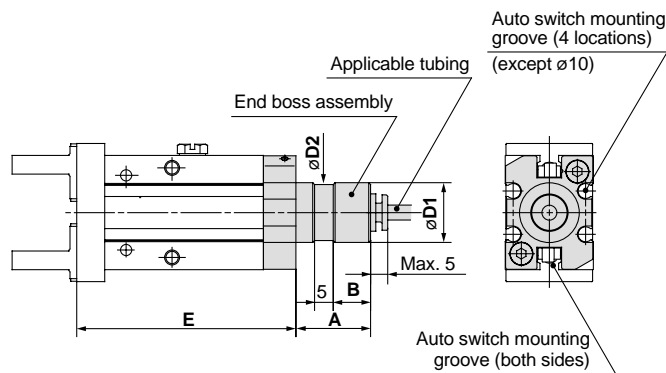

- * Refer to the dimension table.
- * When auto switches are used, side mounting with through holes is not possible.

Unit: mm

Model	A	B	D1	D2	E
MHZ2-10□□	15	7	12f8 ^{-0.016} _{-0.043}	11	52.8
MHZ2-16□□	20	10	16f8 ^{-0.016} _{-0.043}	15	58.7
MHZ2-20□□	22	12	20f8 ^{-0.020} _{-0.053}	19	70.5
MHZ2-25□□	25	15	25f8 ^{-0.020} _{-0.053}	24	82.9

Other dimensions and specifications correspond to the standard type.

Applicable tubing

Description/ Model	Nylon tubing	Soft nylon tubing	Polyurethane tubing	Polyurethane coiled tubing
	T0425	TS0425	TU0425	TCU0425B-1
Outside diameter mm	4	4	4	4
Max. operating pressure MPa	1.0	0.8	0.5	0.5
Min. bending radius mm	13	12	10	—
Operating temperature °C	-20 to 60	-20 to 60	-20 to 60	-20 to 60
Material	Nylon 12	Nylon 12	Polyurethane	Polyurethane

Refer to catalog CAT. E501-B "Air Fittings and Tubing" regarding One-touch fittings and tubing.

Axial Port (M5 Port) [M]

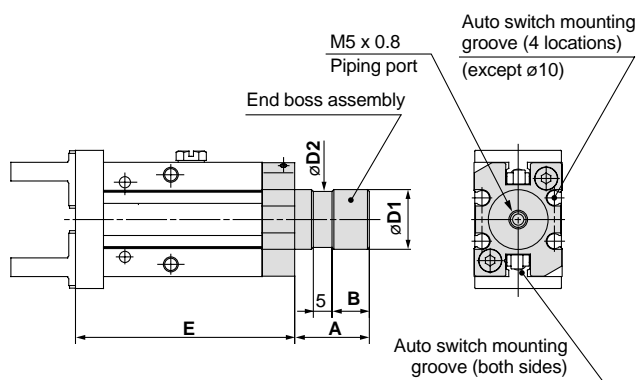

- * Refer to the dimension table.
- * When auto switches are used, side mounting with through holes is not possible.

Unit: mm

Model	A	B	D1	D2	E
MHZ2-10□□	15	7	12f8 ^{-0.016} _{-0.043}	11	52.8
MHZ2-16□□	20	10	16f8 ^{-0.016} _{-0.043}	15	58.7
MHZ2-20□□	22	12	20f8 ^{-0.020} _{-0.053}	19	70.5
MHZ2-25□□	25	15	25f8 ^{-0.020} _{-0.053}	24	82.9

Other dimensions and specifications correspond to the standard type.

Weights

Unit: g

Model	End boss type (symbol)			
	E	W	K	M
MHZ2-10□□	65	64	66	65
MHZ2-16□□	148	147	148	147
MHZ2-20□□	277	277	277	277
MHZ2-25□□	495	495	496	494

Solid-state Auto Switches for Direct Mounting Series D-M9N(V)/D-M9P(V)/D-M9B(V)



Grommet

- Reduced load currents for two-wire model (2.5 to 40 mA)
- Compliance with lead-free requirements
- Use of UL-approved lead wires (style 2844)



Internal circuits

D-M9N/M9NV

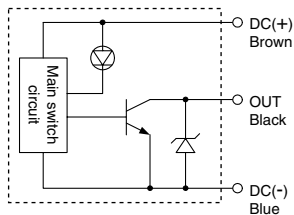

D-M9P/M9PV

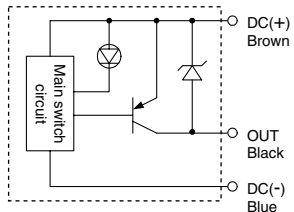

D-M9B/M9BV

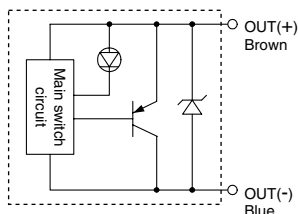

Auto Switch Specifications

PLC: Programmable Logic Controller

D-M9□/D-M9□V (with Indicator light)						
Model number	D-M9N	D-M9NV	D-M9P	D-M9PV	D-M9B	D-M9BV
Electrical entry	In-line	Perpendicular	In-line	Perpendicular	In-line	Perpendicular
Wiring	Three-wire			Two-wire		
Output	NPN		PNP		—	
Applicable load	Integrated circuit, relay and PLC				24 V DC relay and PLC	
Power voltage	5, 12, or 24 V DC (4.5 to 28 V DC)				—	
Current consumption	10 mA or less				—	
Load voltage	28 V DC or less		—		24 V DC (10 to 28 V DC)	
Load current	40 mA or less				2.5 to 40 mA	
Internal voltage drop	0.8 V or less				4 V or less	
Leakage current	100 μA max. at 24 V DC				0.8 mA or less	
Indicator light	Red LED lights when ON.					

- Lead wire: oil-proof heavy-duty vinyl cable
 2.7 x 3.2 with elliptic cross-section, 0.15 mm², two cores (D-M9B),
 or three cores (D-M9N and D-M9P)

Solid state switch specifications

Leakage current	3-wire: 100 μA or less; 2-wire: 0.8 mA max.
Operating time	1 ms or less
Impact resistance	1000 m/s ²
Insulation resistance	50 MΩ or more at 500 V DC (between lead wire and case)
Withstand voltage	1000 V AC for 1 min. (between lead wire and case)
Ambient temperature	-10°C to 60°C
Enclosure	IEC529 standard IP67, JIS C 0920 watertight construction

Weight

Unit: g

Model	D-M9N(V)	D-M9P(V)	D-M9B(V)
Lead wire length (m)	0.5	8	7
	3	41	38
	5	68	63

How to Order

Standard Model Number

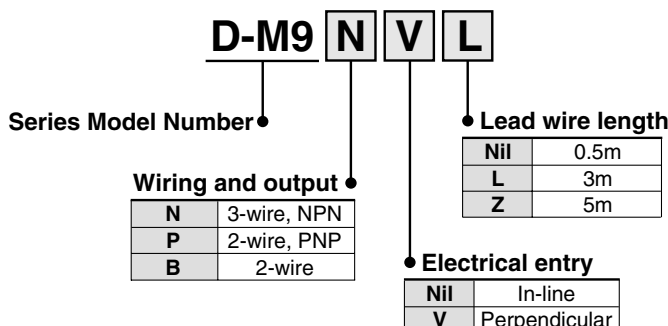

Series D-M9

Auto Switch Dimensions

D-M9□

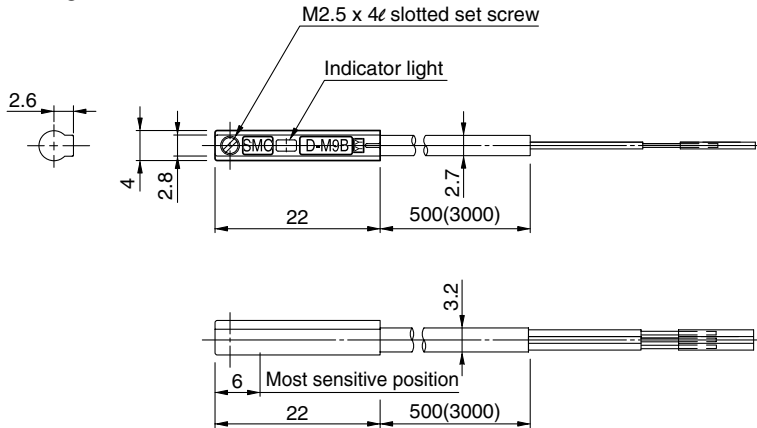

D-M9□V

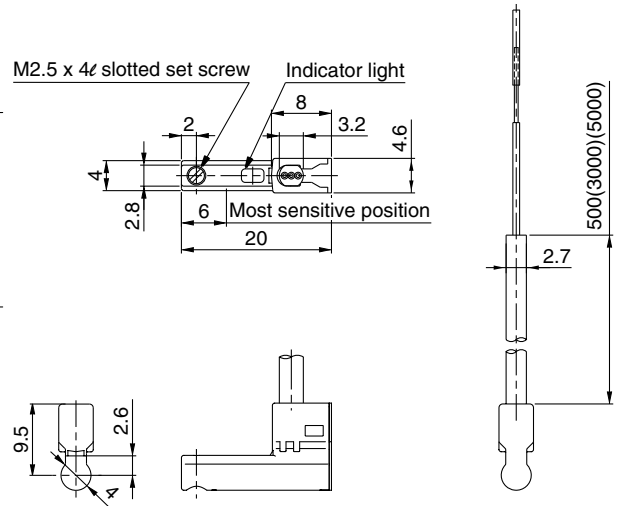

⚠ Specific Product Precautions

Be sure to read before handling. Contact SMC when the required specification is out of range.

Handling

⚠ Caution

Observe the following precautions when handling the product.

- The D-M9 series of auto switches is not overcurrent-protected. Faulty wiring or short circuit may result in breakage or burning-out of the switch.
- When stripping the cable clad, be careful about the orientation of the cable being stripped. The insulator may be accidentally torn or damaged depending on the orientation, as shown on the right.

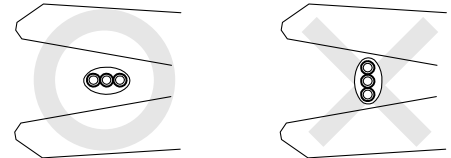

- We recommend the following tools

Manufacturer	Product name	Product number
VESSEL	Wire stripper	No 3000G
Tokyo Ideal	Strip master	45-089

* The stripper for the round shape cords (ø2.0) is for a 2-wire style.

- Please do not attach the switch with any other screws than those already attached to the auto switch body.

The operation range is shorter than that of the conventional models.

If the auto switch replaces the conventional model, it may not function depending on its application because the operation range is shorter. Refer to the examples below.

- In an application where at the end, the stopping position shifting range is larger than the operation range. For example, pushing a work against something, or pressing a work into a hole, or clamping a work.
- In an application where the auto switch is used to detect an intermediate stopping position. (Detecting time is shortened.)

Note) Please contact SMC for the operation range details for each actuator.

The switch is damaged instantly when a load is shortened since short circuit protection is not built-in. Pay special attention to avoid reversing the connection of the brown lead of the power supply line and the black output line connection.