

# Rotary Table/Vane Type: Basic

# Series MSUB

## Sizes 1, 3, 7, 20



### How to Order

**Bearing type**

B	Basic type
---	------------

**Free-mount**

**Connection port position**

Nil	Side ports
E	Top ports

Available with side ports only, when equipped with switch unit.

**Without Auto Switch Unit**

**MSUB 20-90-S**

**With Auto Switch Unit**

**M D SUB 20-90-S R73 L**

**Nominal size (torque)**

1	MSUB 1
3	MSUB 3
7	MSUB 7
20	MSUB 20

**Rotation**

Application	Symbol	Rotation
Single vane	90	90°
	180	180°
Double vane	90	90°

Rotation adjustment range  
 Single vane: Both ends ±5° each  
 Double vane: Both ends ±2.5° each

**Vane type**

S	Single vane
D	Double vane

**Number of auto switches**

S	1 pc.*
Nil	2 pcs.

\* For 1 piece, a right hand auto switch is installed.

**Electrical entry/Lead wire length**

Nil	Grommet/lead wire 0.5m
L	Grommet/lead wire 3m
C	Connector/lead wire 0.5m
CL	Connector/lead wire 3m
CN	Connector/without lead wire

\* Available only with R73, R80 and T79 type connectors.  
 \*\* Lead wire with connector part nos.  
 D-LC05: Lead wire 0.5m  
 D-LC30: Lead wire 3m  
 D-LC50: Lead wire 5m

**Type of auto switch**

Nil	Without auto switch
-----	---------------------

\* Select applicable auto switches from the table below.

### Applicable auto switches/Refer to pages 26 through 35 for detailed auto switch specifications.

Applicable model	Type	Electrical entry	Indicator light	Wiring (output)	Load voltage		Auto switch part no.	Lead wire type	Lead wire length (m)*				Applicable loads															
					DC	AC			0.5 (Nil)	3 (L)	5 (Z)	None (N)																
MDSUB1 MDSUB3	Reed	Grommet	No	2 wire	24V	5V, 12V	5V, 12V, 24V	90	Parallel cord	●	●	●	—	Relay, PLC														
						5V, 12V, 100V	5V, 12V, 24V, 100V	90A	Heavy duty	●	●	●	—															
						—	100V	93A	Parallel cord	●	●	●	—															
	Solid state					Yes	3 wire (NPN)	24V	5V, 12V	—	T99	Heavy duty	—		●	●	—	—										
											T99V				●	●	—	—										
											S99				●	●	—	—										
Grommet	Yes	3 wire (PNP)	24V	5V, 12V	—						S99V			Heavy duty	—	●	●	—	—									
											S9P					●	●	—	—									
											S9PV					●	●	—	—									
Reed						Grommet	Yes	2 wire	24V	—	100V	R73	Heavy duty			—	●	●	—	—								
												R73C					●	●	●	●								
												Connector					No	2 wire	24V	48V, 100V	24V, 48V, 100V	R80	Heavy duty	—	●	●	—	—
	R80C	●	●	●	●																							
	Solid state	Yes	3 wire (NPN)	24V	12V							—		T79	Heavy duty							—			●	●	—	—
														T79C											●	●	●	●
Grommet						Yes	3 wire (PNP)	24V	5V, 12V	—	S79		Heavy duty	—		●									●	—	—	
											S7P					●									●	—	—	

- Order example: MSUA20 single vane type (connection port side position selected)
- Standard type (without auto switches), rotation 90°, side port position MSUB20-90S
  - With switch unit (without auto switches), rotation 180°, side port position MDSUB20-180S
  - With switch unit + auto switch R73, rotation 180°, side port position MDSUB20-180S-R73

\* Lead wire length symbols 0.5m ..... Nil (Example) R73C ● Operating time — 1.2ms ● Operating temperature range — 5 to 60°C  
 3m ..... L (Example) R73CL ● Impact resistance — 300m/s<sup>2</sup> (reed), 1000m/s<sup>2</sup> (solid state)  
 5m ..... Z (Example) R73CZ  
 None ..... N (Example) R73CN

## Specifications

Model <sup>3*</sup>		MSUB1			MSUB3			MSUB7			MSUB20		
<b>Vane type</b>		Single vane		Double vane	Single vane		Double vane	Single vane		Double vane	Single vane		Double vane
<b>Rotation <sup>1*</sup></b>		90°±10°		180°±10°	90°±5°		180°±10°	90°±5°		180°±10°	90°±5°		180°±10°
<b>Fluid</b>		Air (unlubricated)											
<b>Proof pressure MPa</b>		1.05						1.5					
<b>Ambient and fluid temperature</b>		5 to 60°C											
<b>Operating pressure range MPa</b>		0.2 to 0.7			0.15 to 0.7						0.15 to 1.0		
<b>Rotation time adjustment range sec/90°</b>		0.07 to 0.3											
<b>Shaft load</b>	<b>Allowable radial load</b>	20N			40N			50N			60N		
	<b>Allowable thrust load <sup>2*</sup></b>	15N			30N			60N			80N		
	<b>Allowable moment</b>	10N			15N			30N			40N		
<b>Bearing</b>		Bearings											
<b>Port position</b>		Side ports or Top ports											
<b>Port size</b>	<b>Side ports</b>	M3 x 0.5			M5 x 0.8								
	<b>Top ports</b>	M3 x 0.5						M5 x 0.8					

- \*1. Single vane 90° type can be adjusted to 90°±10° (both ends of rotation ±5° each)  
 Single vane 180° type can be adjusted to 180°±10° (both ends of rotation ±5° each)  
 Double vane 90° type can be adjusted to 90°±5° (both ends of rotation ±2.5° each)  
 • Rotation angles other than 90° and 180° (single vane) are available by special order.

\*2. The allowable thrust load is directional. For details refer to the allowable load table below.

(Note) Refer to page 39 for allowable kinetic energy.

\*3. Correspondence to equivalent conventional free-mount types

Rotary table	Free-mount rotary actuator
MSUB 1	CRBUW10
MSUB 3	CRBUW15
MSUB 7	CRBUW20
MSUB20	CRBUW30

## Table Rotation Range

Angle adjustment is possible as shown in the drawings below using adjustment bolts (A) and (B).

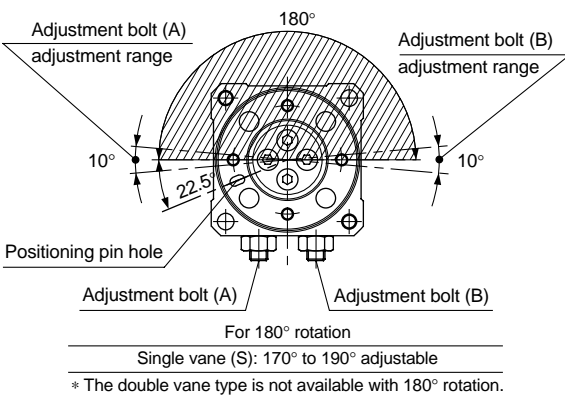
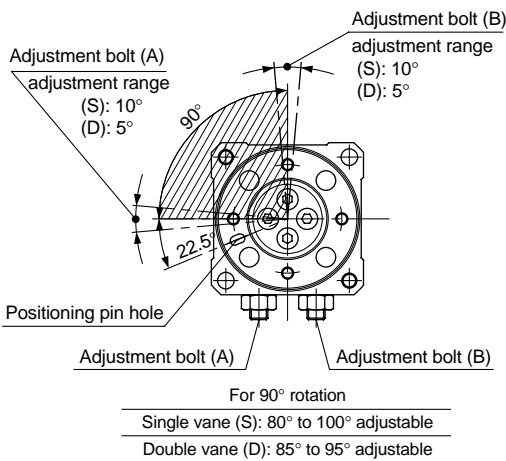

## Applicable Auto Switches

Auto switch type	MDSUB1, 3	MDSUB7, 20
Reed switch	D-90/97, D-90A/93A	D-R7, R8
Solid state switch	D-S99, D-T99, D-S9P	D-S7, D-S7P, T7

## Weights

Unit: g

Size	Rotation	Basic weight		Auto switch unit + Auto switch 2 pcs.
		Single vane	Double vane	
1	90	145	150	25
	180	140	—	
3	90	230	240	30
	180	225	—	
7	90	360	375	50
	180	355	—	
20	90	510	580	60
	180	505	—	

## Allowable Loads

Do not permit the load and moment applied to the table to exceed the allowable values shown in the table below. (Operation above the allowable values can cause adverse effects on service life, such as play in the table and loss of accuracy.)

Size	Allowable radial load (N)	Allowable thrust load (N)		Allowable moment (N·m)
1	20	(A) 15	(B) 10	0.3
3	40	30	15	0.7
7	50	60	30	0.9
20	60	80	40	2.9

# Series MSUB

## Dimensions

These drawings indicate the condition when the B port is pressurized.

### MSUB1 (Single vane)

#### MSUB1-□S, SE

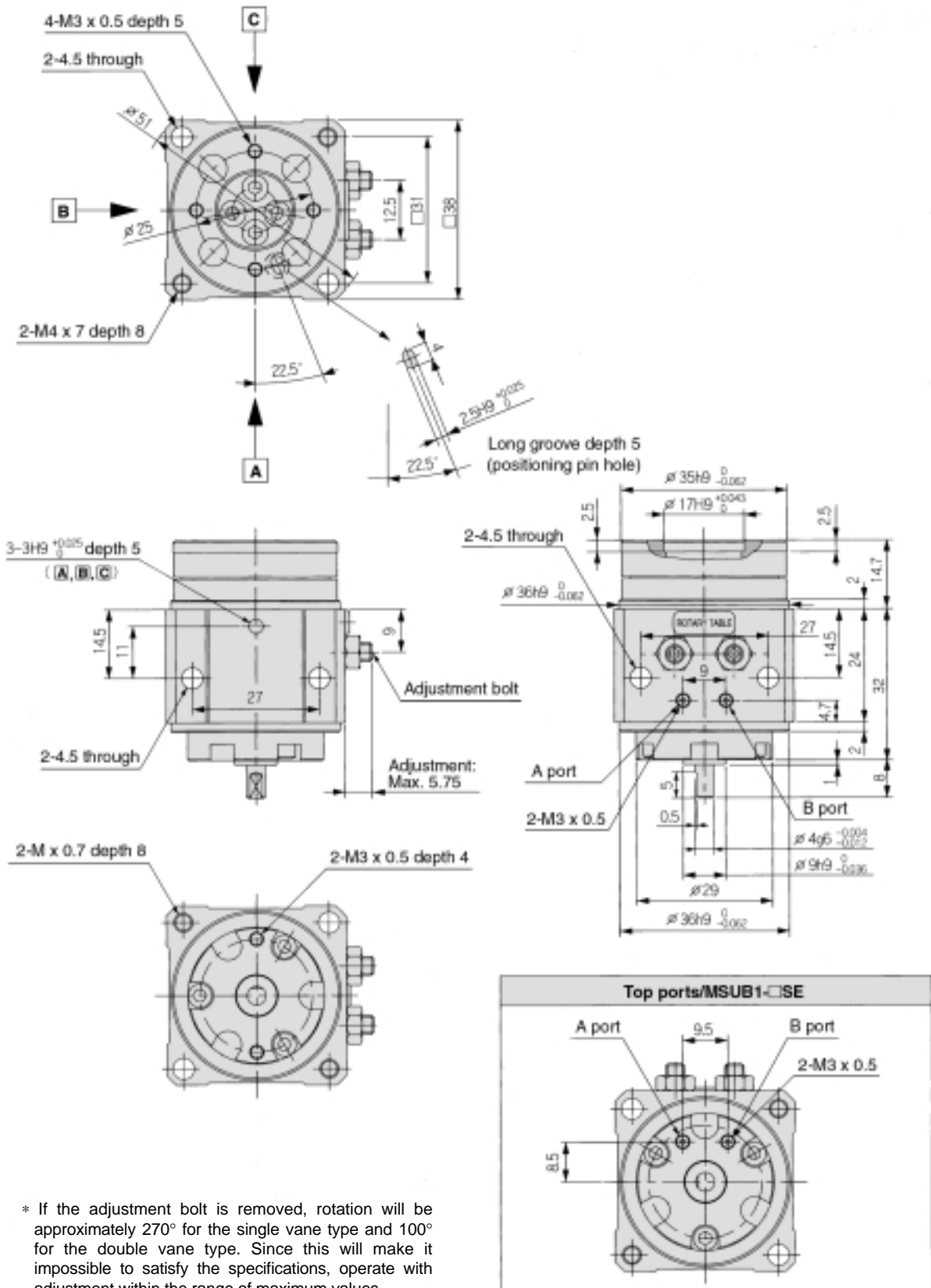

\* If the adjustment bolt is removed, rotation will be approximately 270° for the single vane type and 100° for the double vane type. Since this will make it impossible to satisfy the specifications, operate with adjustment within the range of maximum values.

These drawings indicate the condition when the B port is pressurized.

## With auto switch: MDSUB1-□S

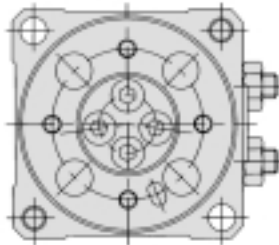

- \*1) When using 24 : D-90, 90A, S99(V), T99(V), S9P(V)  
When using 30 : D-97, 93A
- \*2) When using 60° : D-90, 90A, 97, 93A  
When using 69° : D-S99(V), T99(V), S9P(V)

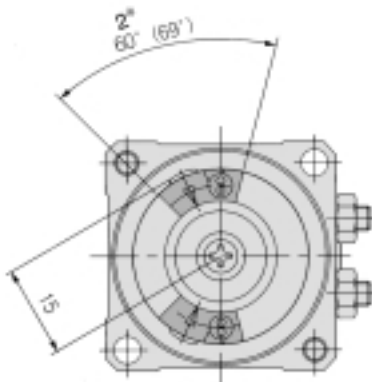
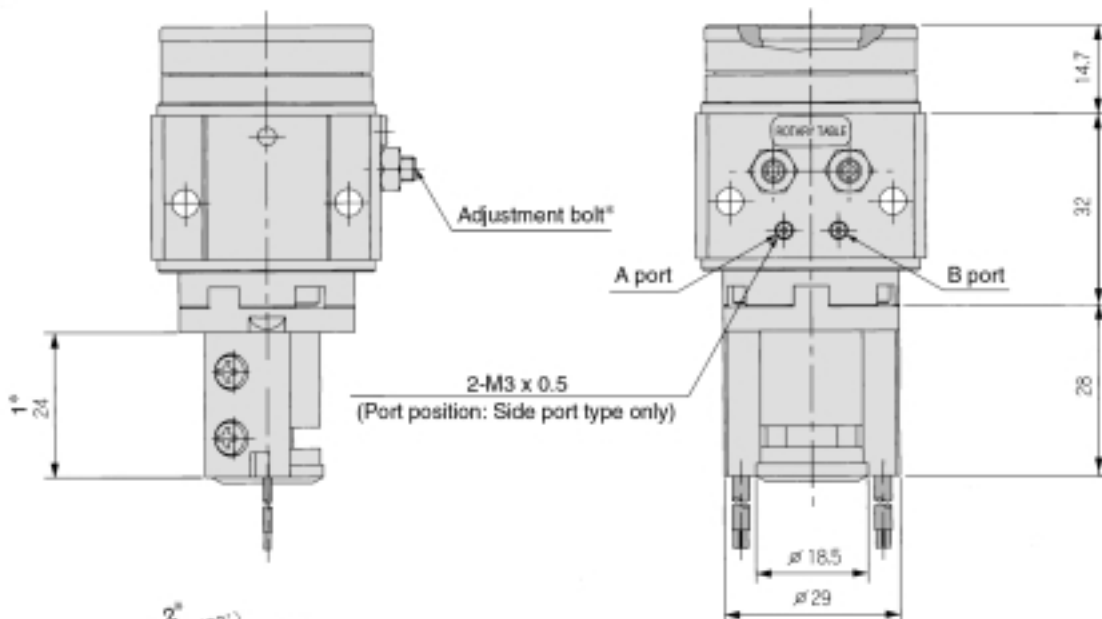

D-97, 93A

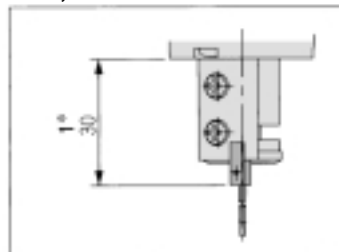

\* If the adjustment bolt is removed, rotation will be approximately 270° for the single vane type and 100° for the double vane type. Since this will make it impossible to satisfy the specifications, operate with adjustment within the range of maximum values.

# Series MSUB

## Dimensions

These drawings indicate the condition when the B port is pressurized.

### MSUB1 (Double vane)

#### MSUB1-□D

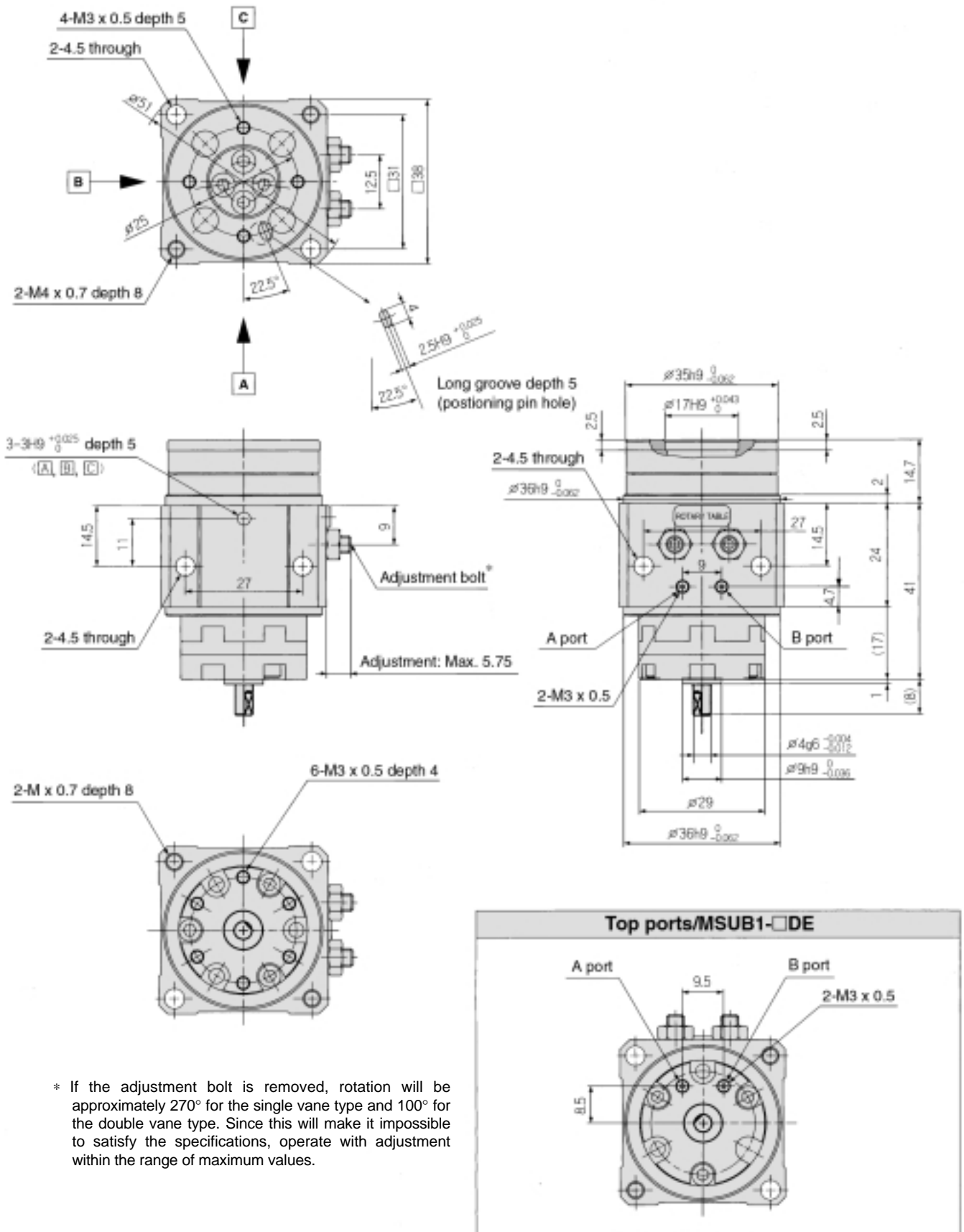

\* If the adjustment bolt is removed, rotation will be approximately 270° for the single vane type and 100° for the double vane type. Since this will make it impossible to satisfy the specifications, operate with adjustment within the range of maximum values.

These drawings indicate the condition when the B port is pressurized.

## With auto switch: MDSUB1-□D

\*1) When using 24 : D-90, 90A, S99(V), T99(V), S9P(V)  
When using 30 : D-97, 93A

\*2) When using 60° : D-90, 90A, 97, 93A  
When using 69° : D-S99(V), T99(V), S9P(V)

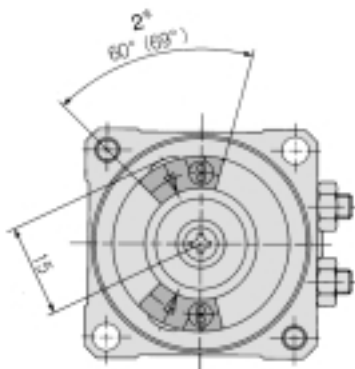
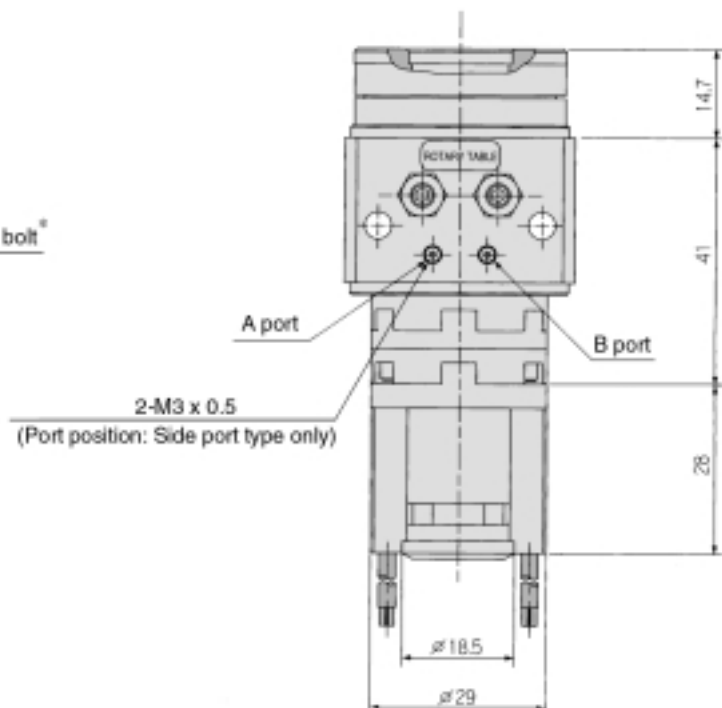
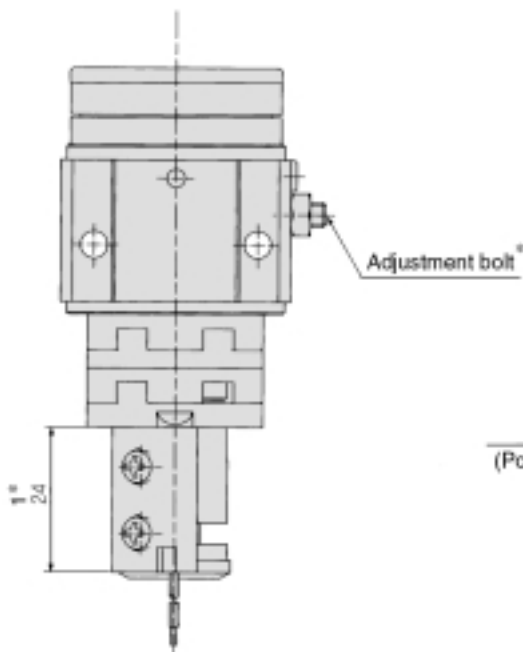
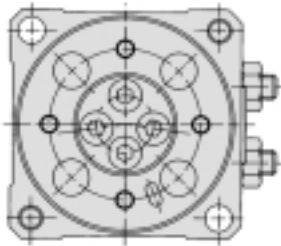

### D-97, 93A

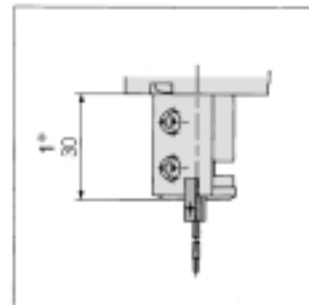

\* If the adjustment bolt is removed, rotation will be approximately 270° for the single vane type and 100° for the double vane type. Since this will make it impossible to satisfy the specifications, operate with adjustment within the range of maximum values.

# Series MSUB

## Dimensions

These drawings indicate the condition when the B port is pressurized.

### MSUB3 (Single vane, Double vane)

MSUB3-□S, D

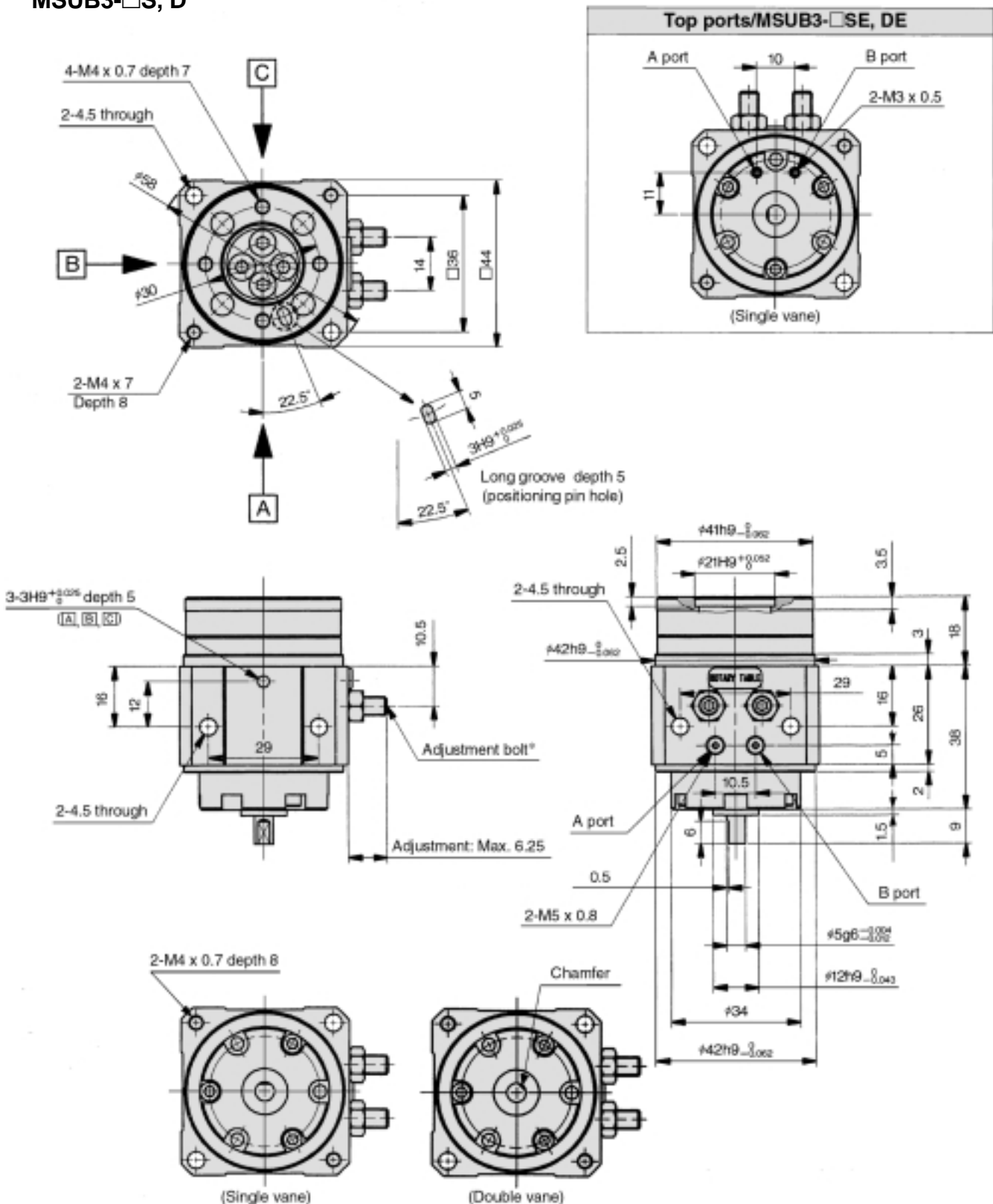

The outside drawings show the single vane type, but only the position of the chamfered sections shown in the above drawings differs for single and double vane.

\* If the adjustment bolt is removed, rotation will be approximately 270° for the single vane type and 100° for the double vane type. Since this will make it impossible to satisfy the specifications, operate with adjustment within the range of maximum values.

These drawings indicate the condition when the B port is pressurized.

## With auto switch: MDSUB3

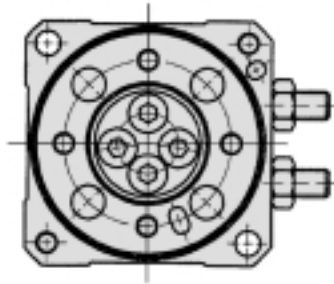

\*1) When using 24 : D-90, 90A, S99(V), T99(V), S9P(V)  
When using 30 : D-97, 93A

\*2) When using 60° : D-90, 90A, 97, 93A  
When using 69° : D-S99(V), T99(V), S9P(V)

\* If the adjustment bolt is removed, rotation will be approximately 270° for the single vane type and 100° for the double vane type. Since this will make it impossible to satisfy the specifications, operate with adjustment within the range of maximum values.

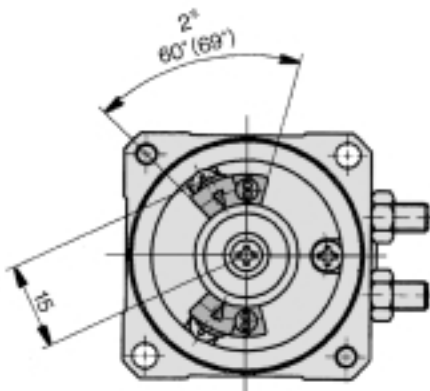
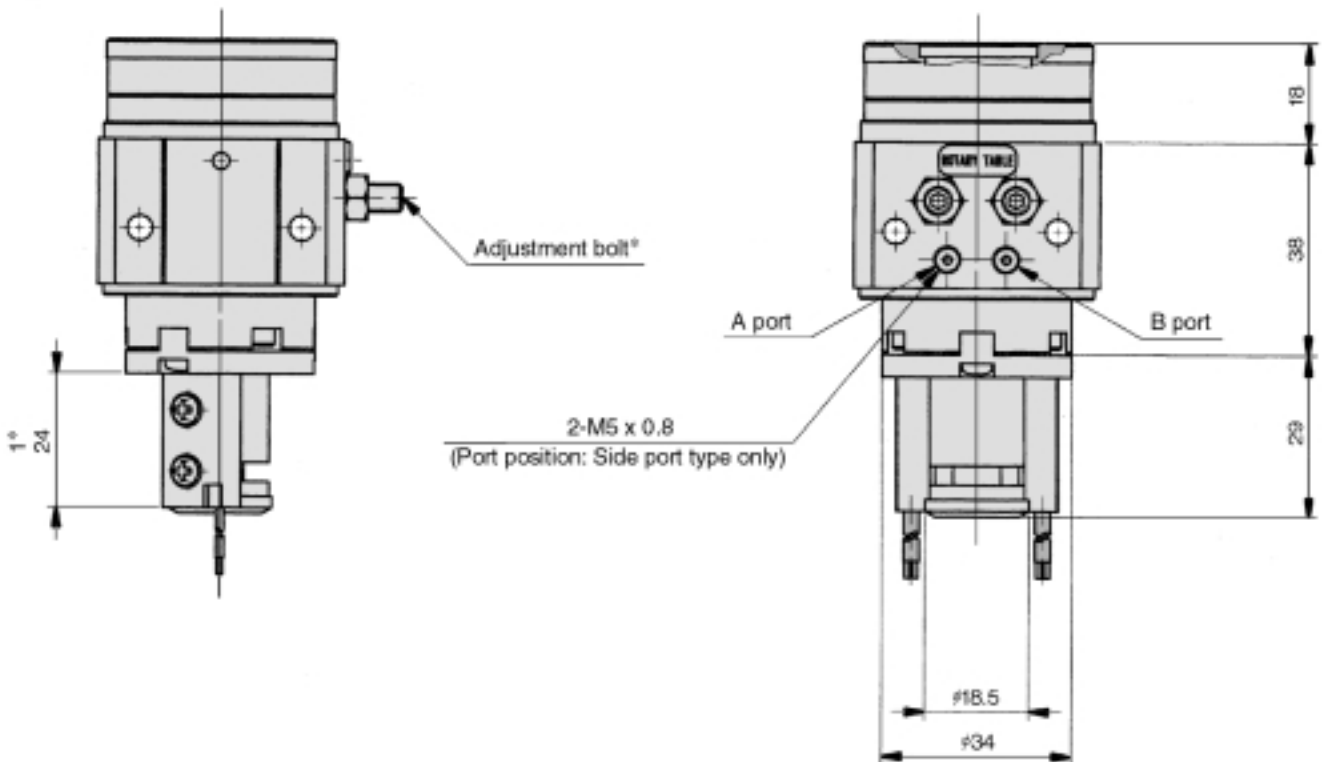

## D-97, 93A

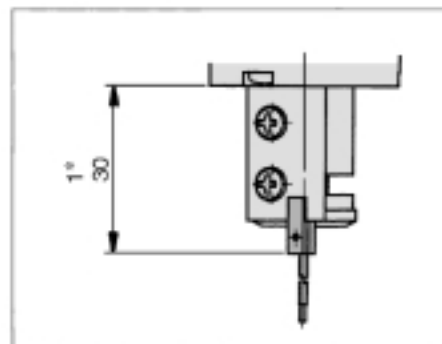

# Series MSUB

## Dimensions

These drawings indicate the condition when the B port is pressurized.

### MSUB7 (Single vane, Double vane)

MSUB7-□S, D

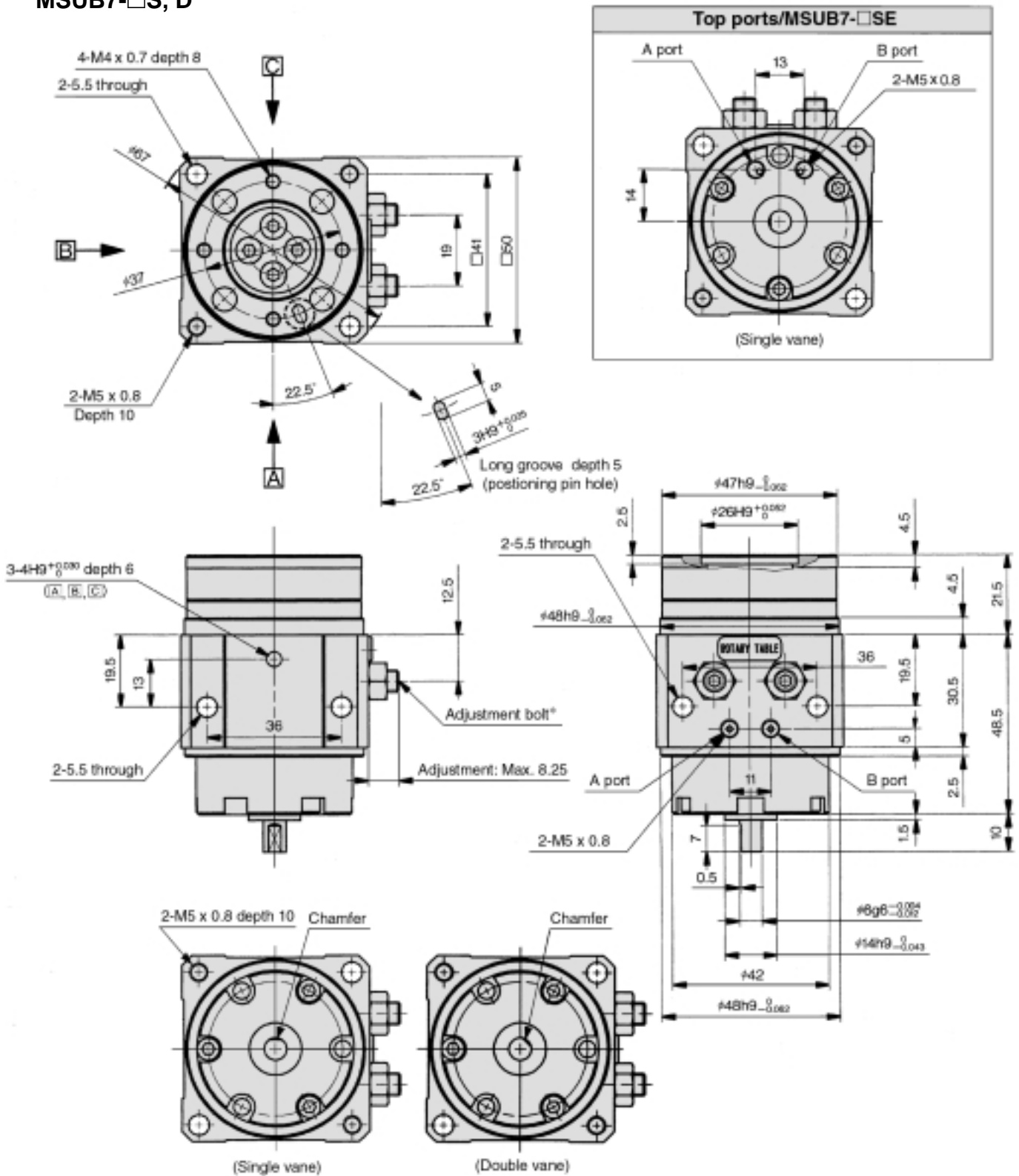

The outside drawings show the single vane type, but only the position of the chamfered sections shown in the above drawings differs for single and double vane.

\* If the adjustment bolt is removed, rotation will be approximately 270° for the single vane type and 100° for the double vane type. Since this will make it impossible to satisfy the specifications, operate with adjustment within the range of maximum values.

These drawings indicate the condition when the B port is pressurized.

## With auto switch: MDSUB7

- \*1) 25.5: Grommet type  
34.5: Connector type
- \*2) 20.5: Grommet type  
26.5: Connector type

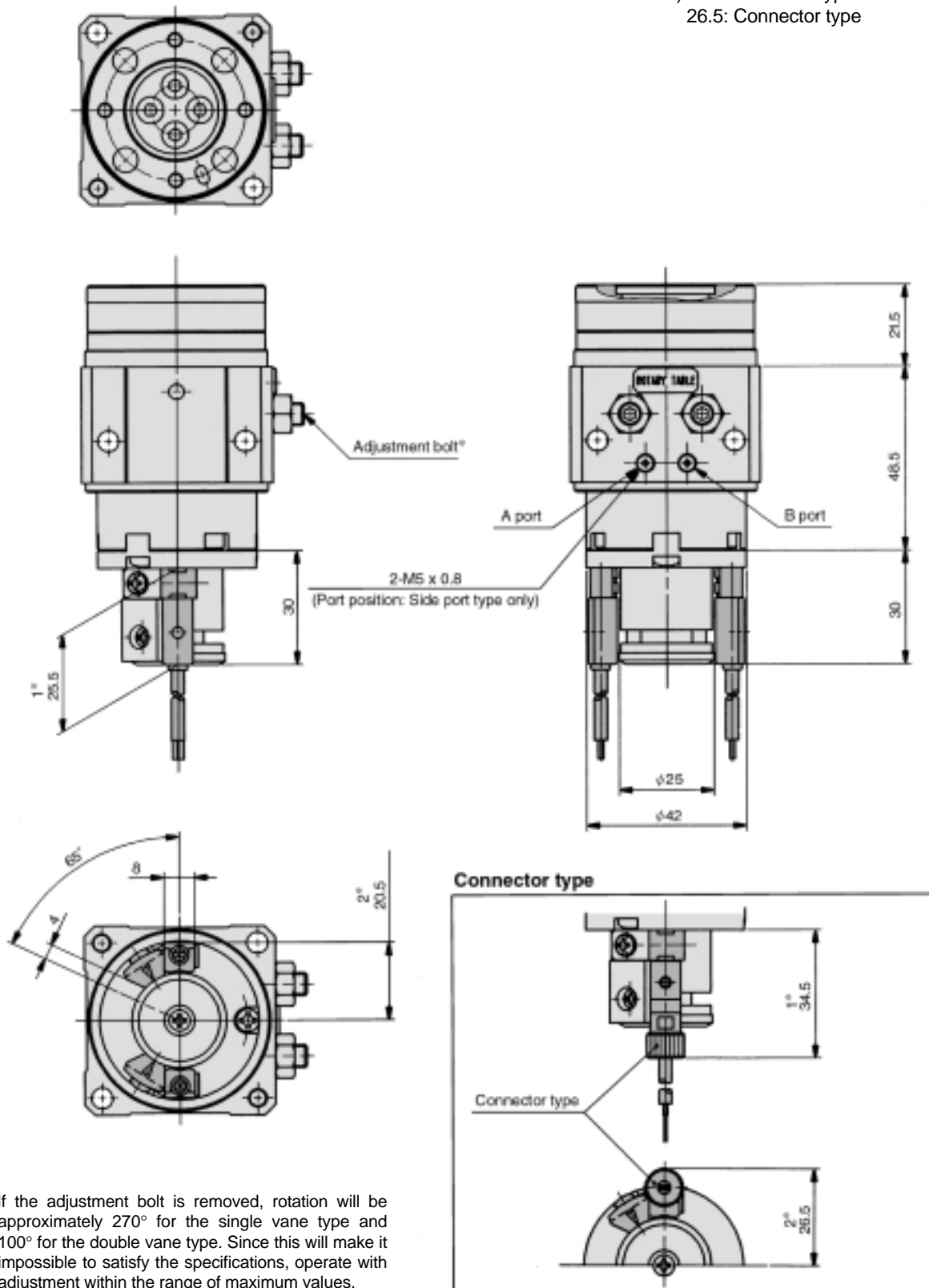

\* If the adjustment bolt is removed, rotation will be approximately 270° for the single vane type and 100° for the double vane type. Since this will make it impossible to satisfy the specifications, operate with adjustment within the range of maximum values.

# Series MSUB

## Dimensions

These drawings indicate the condition when the B port is pressurized.

### MSUB20 (Single vane, Double vane)

MSUB20-□S, D

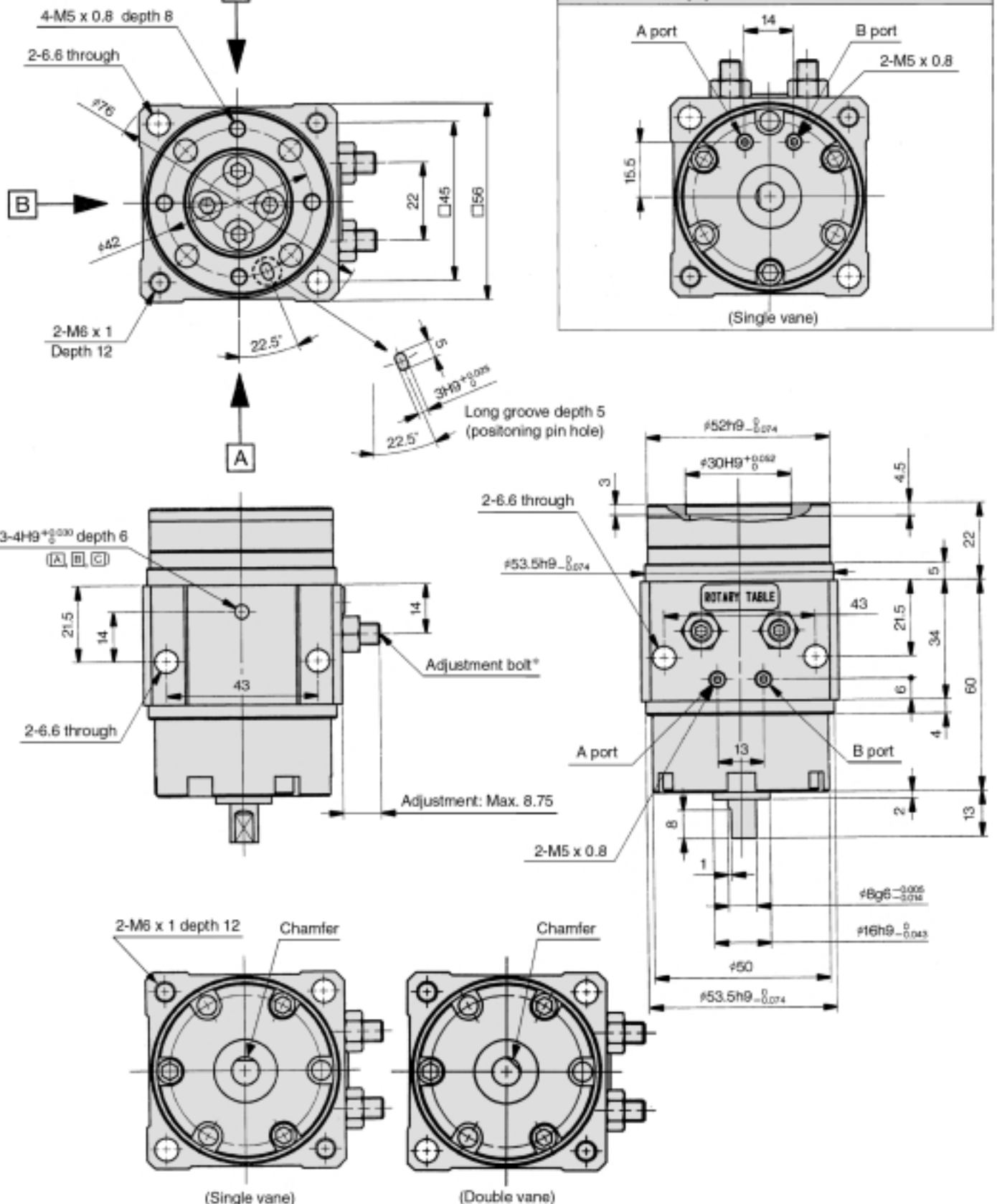

The outside drawings show the single vane type, but only the position of the chamfered sections shown in the above drawings differs for single and double vane.

\* If the adjustment bolt is removed, rotation will be approximately 270° for the single vane type and 100° for the double vane type. Since this will make it impossible to satisfy the specifications, operate with adjustment within the range of maximum values.

These drawings indicate the condition when the B port is pressurized.

## With auto switch: MDSUB20

- \*1) 25.5: Grommet type  
34.5: Connector type
- \*2) 20.5: Grommet type  
26.5: Connector type

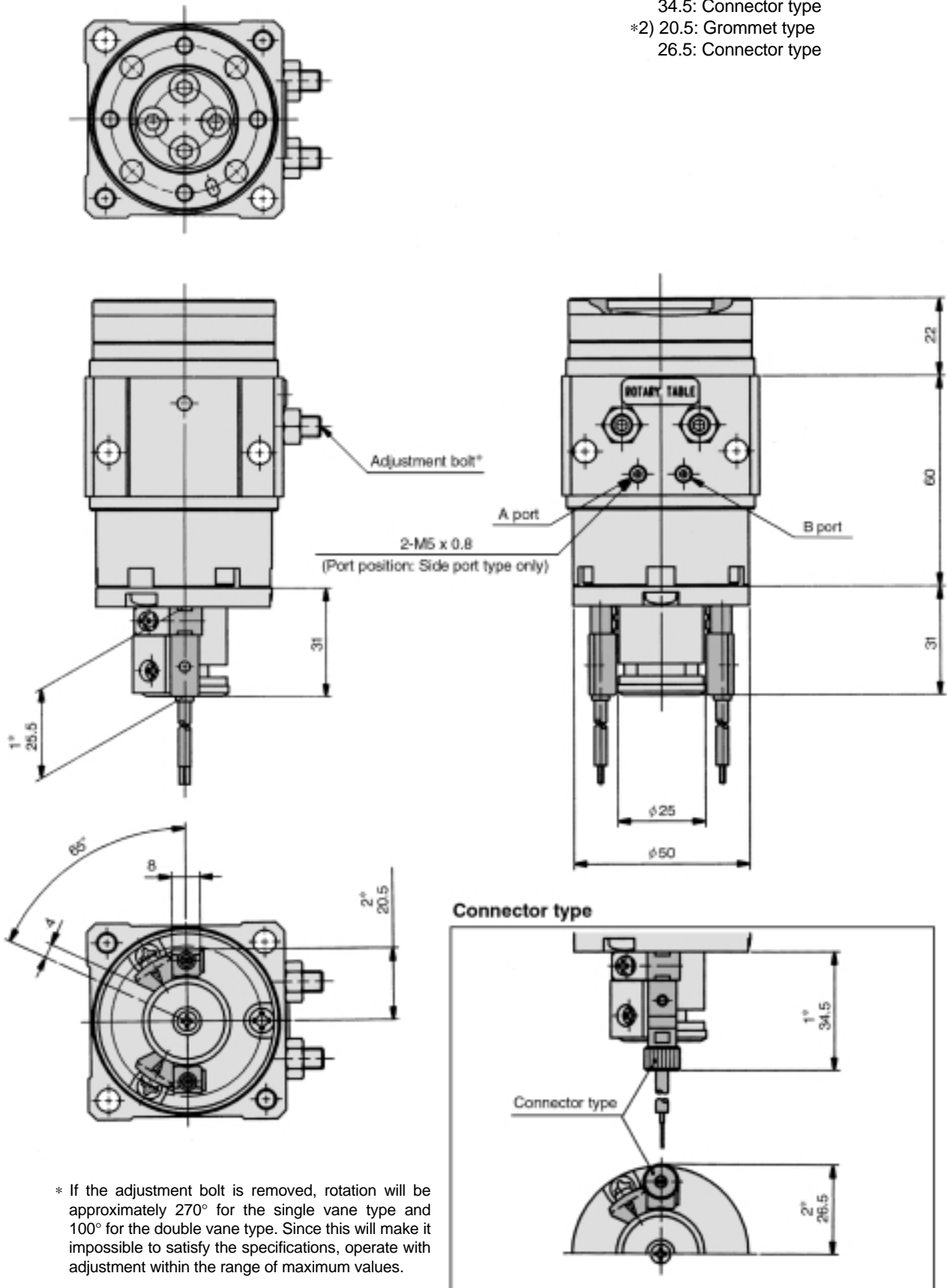

\* If the adjustment bolt is removed, rotation will be approximately 270° for the single vane type and 100° for the double vane type. Since this will make it impossible to satisfy the specifications, operate with adjustment within the range of maximum values.

# Series MSUB

## Construction/Parts List

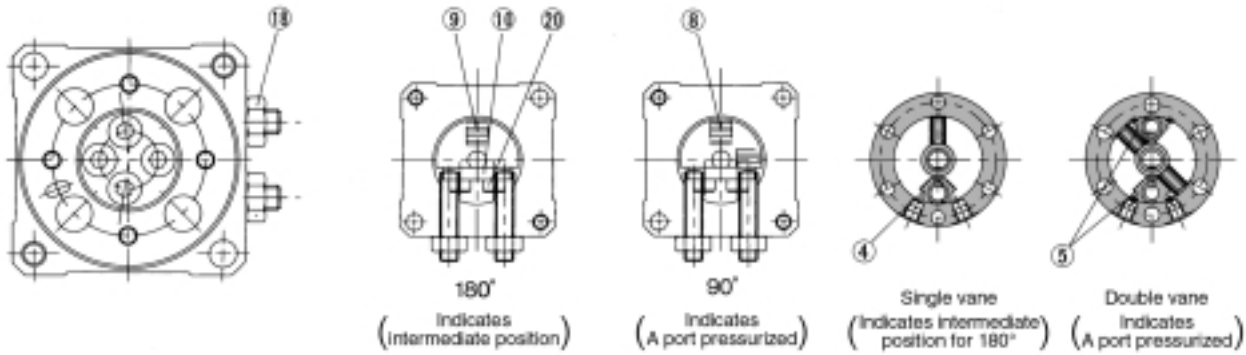

Single vane: Size 1

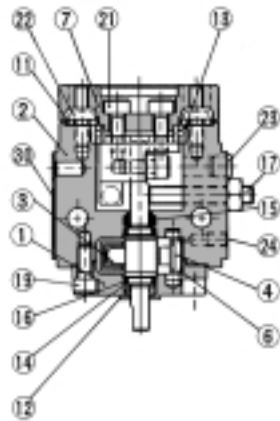

Double vane: Size 1

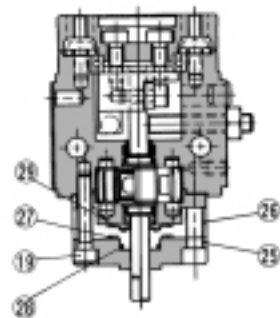

Single vane: Sizes 3, 7, 20

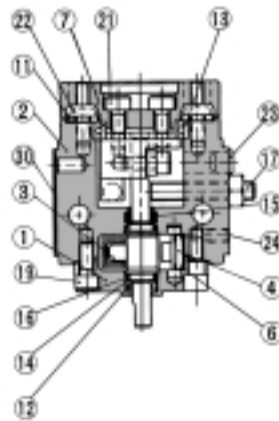

Double vane: Sizes 3, 7, 20

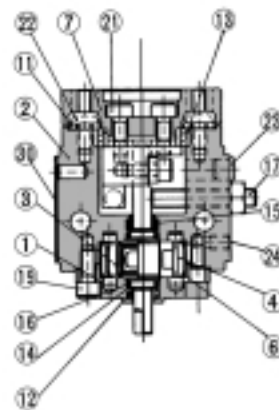

### Parts list

No.	Description	Material	Note
1	Body (A)	Aluminum alloy	Light gray color
2	Body (B)	Aluminum alloy	Light gray color
3	Vane shaft	Stainless steel (MSUB20: Carbon steel)	Single vane
		Carbon steel	Double vane
4	Stopper	Resin	Single vane
5	Stopper	Stainless steel	Double vane
6	Stopper seal	NBR	
7	Table	Aluminum alloy	Light gray color
8	Stopper lever (D)	Carbon steel	
9	Stopper lever (S)	Carbon steel	
10	Lever retainer	Carbon steel	
11	Ring collar	Carbon steel	
12	Bearing	High carbon chrome bearing steel	
13	Bearing	High carbon chrome bearing steel	
14	Back-up ring	Stainless steel	
15	Scraper	NBR	
16	O-ring	NBR	
17	Adjustment bolt	Carbon steel	
18	Hexagon nut	Stainless steel	
19	Hexagon socket head cap screw	Stainless steel	
20	Hexagon socket head cap screw	Stainless steel	
21	Hexagon socket head cap screw	Stainless steel	
22	Button bolt	Carbon steel	
23	Rubber cap	NBR	
24	Hexagon socket head set screw	Stainless steel	
25	Cover	Aluminum alloy	SE type only
26	Plate	Resin	
27	Gasket	NBR	
28	O-ring	NBR	
29	O-ring	NBR	
30	Label		

\* The plug number 24 is used only when the connection port is type SE.

### Internal construction with auto switch

Units are common for both single and double vane.

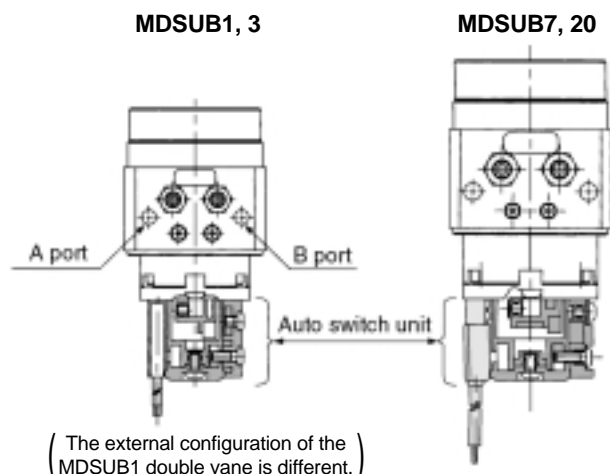

(The external configuration of the MDSUB1 double vane is different.)

Model	Auto switch unit part no.
MDSUB 1	P211070-1
MDSUB 3	P211090-1
MDSUB 7	P211060-1
MDSUB20	P211080-1

\* Auto switches are not included with switch units.

Auto switch block unit		
For MDSUB1, 3		For MDSUB7, 20
Right-handed	Left-handed	Combination left & right-handed
Part no.: P211070-8	Part no.: P211070-9	Part no.: P211060-8

\* A switch block unit is the assembly required to mount one auto switch on a switch unit.