

Series MXS

Adjuster Options

Stroke adjuster

- Adjustable stroke range: 0 to 5mm

With adjuster at extension end (AS)
 With adjuster at retraction end (AT)
 With adjuster at both ends (A)

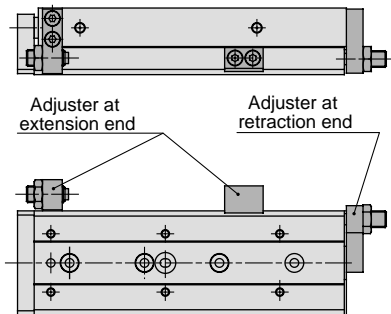

With shock absorber

- Absorbs the collision at stroke end and stops smoothly.
- Enables adjustment of stroke

With shock absorber at extension end (BS)
 With shock absorber at retraction end (BT)
 With shock absorber at both ends (B)

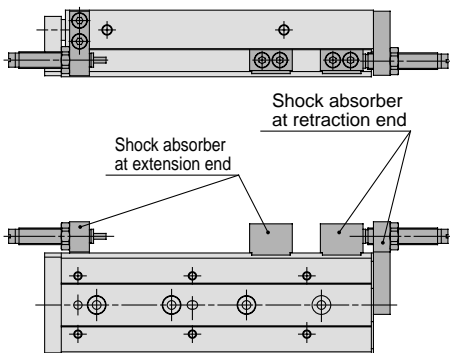

Functional Options

With buffer

- Cushioning at the extending stroke end protects the work and tool.
- Auto switch is attachable at buffer section.

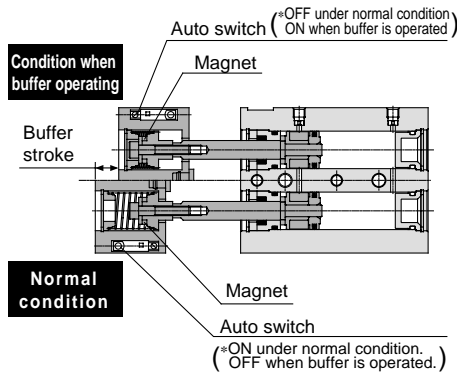

*ON/OFF setting can be changed with auto switch mounting direction.

Applicable example

Buffer mechanism absorbs shock and prevents damage to work in case the positioning is not accurate when load is inserted.

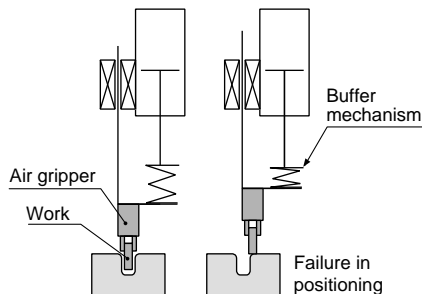

With end lock

- Keeps cylinder at original position and prevents the load from dropping when air is cut off.

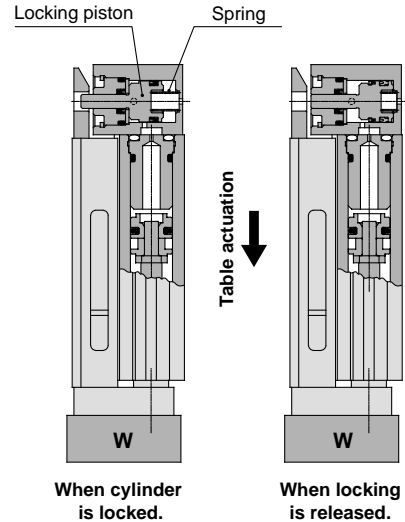

Axial piping

- Centralized piping in axial direction saves space around the body.

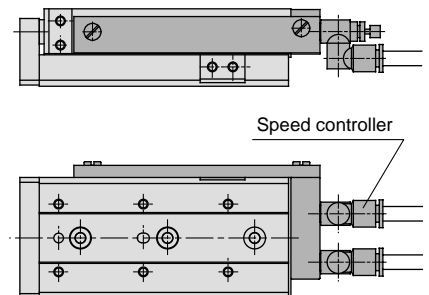



Series MXS/Precautions^①

Be sure to read before handling.

Refer to p.0-39 to 0-43 for Safety Instructions and actuator precautions.

Selection

⚠ Caution

① Do not apply a load over the operating limit range.

Select the model considering max. allowable load and allowable moment. Refer to p.3.11-10 and 3.11-11 for the details. When actuator is used outside of operating limits, eccentric loads on guide will be in excess this causing vibration on guide and inaccuracy, and shortens life.

② If intermediate stops by external stopper is done, avoid ejection.

If ejection occurs, it may cause damage. In case the slid table is stopped at intermediate positions by an external stopper then forwarded to the front, return the slide table to the back for just a moment to retract the stopper, then supply pressure to the opposite port to operate slide table.

③ Do not apply excessive forces and impacts.

This will cause problems and possible failure.

Mounting

⚠ Caution

① Do not scratch and dent mounting side of body, table and end plate.

The damage will result in a decrease in parallelism, vibration of guide and an increase in moving part resistance.

② Do not scratch and dent forward side of rail and guide.

This causes vibration and increases moving part resistance.

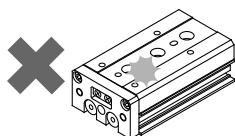

Mounting

③ Do not apply excessive power and load when work is mounted.

Vibrations on guide and moving part resistance will result when power over the allowable moment is applied.

④ Flatness of mounting surface should be less than 0.02mm.

Insufficient flatness of workpiece or base to which Air Slide Table is mounted can cause generation of play at guide section or increase sliding resistance.

⑤ Select the proper connection with the load which has external support and/or guide mechanism on the outside, and align it properly.

⑥ Avoid contact with the air slide table during operation.

Adjuster option creates additional pinch points which can cause injury to operator when table is moving. Preventative measures, e.g. installation of a cover, should be taken to avoid such accidents.

⑦ Keep away from objects which is influenced by magnets.

A magnet is built in the guide block for use with an auto switch, there for do not use magnetic disk, magnetic card, or magnetic tape, else data will be eliminated.

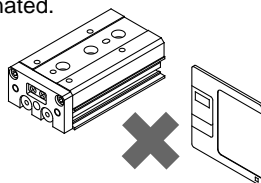

⑧ When mounting an air slide table, use appropriate length of screws and do not exceed the maximum tightening torque.

If tightening the screw beyond the designated value, it may malfunction. If tightening it insufficiently, it may result in position sliding or falling off of air slide table.

1. Lateral mounting (Body tapped)

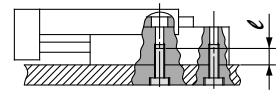

Model	Bolt	Max. torque (Nm)	Max. screw-in depth l (mm)
MXS 6	M4 X 0.7	2.1	8
MXS 8	M4 X 0.7	2.1	8
MXS12	M5 X 0.8	4.4	10
MXS16	M6 X 1	7.4	12
MXS20	M6 X 1	7.4	12
MXS25	M8 X 1.25	18	16

2. Lateral mounting (Through hole)

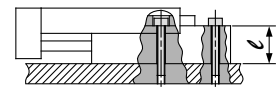

Model	Bolt	Max. torque (Nm)	Max. screw-in depth l (mm)
MXS 6	M3 X 0.5	1.2	11
MXS 8	M3 X 0.5	1.2	13
MXS12	M4 X 0.7	2.8	18.5
MXS16	M5 X 0.8	5.7	24
MXS20	M5 X 0.8	5.7	29
MXS25	M6 X 1	10	34

3. Axial mounting (Body tapped)

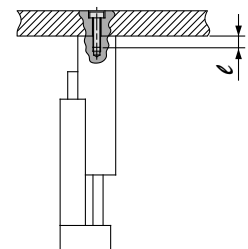

Model	Bolt	Max. torque (Nm)	Max. screw-in depth l (mm)
MXS 6	M2.5 X 0.45	0.5	3.5
MXS 8	M3 X 0.5	0.9	4
MXS12	M4 X 0.7	2.1	6
MXS16	M5 X 0.8	4.4	7
MXS20	M5 X 0.8	4.4	8
MXS25	M6 X 1	7.4	10

CL

MLGC

CNA

CB

CV/MVG

CXW

CXS

CXT

MX

MXU

MXS

MXQ

MXF

MXW

MXP

MG

MGP

MGQ

MGG

MGC

MGF

CY1

MY1



Series MXS/Precautions^②

Be sure to read before handling.

Refer to p.0-39 to 0-43 for Safety Instructions and actuator precautions.

Mounting

⚠ Caution

1. Front face mounting

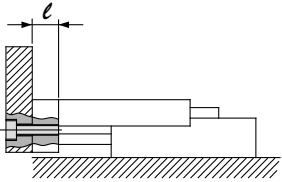

Model	Bolt	Max. torque (Nm)	Max. screw-in depth l (mm)
MXS 6	M3 X 0.5	0.9	5
MXS 8	M4 X 0.7	2.1	6
MXS12	M5 X 0.8	4.4	8
MXS16	M6 X 1	7.4	10
MXS20	M6 X 1	7.4	13
MXS25	M8 X 1.25	18	15

2. Top face mounting

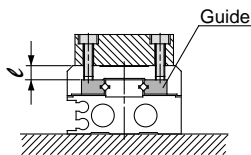

⚠ Caution

When attaching work to guide, use a bolt which is at least 0.5mm shorter than the maximum thread depth. Longer bolts can cause malfunction due to contact with guide bearings.

Model	Bolt	Max. torque (Nm)	Max. screw-in depth l (mm)
MXS 6	M3 X 0.5	0.9	4
MXS 8	M3 X 0.5	0.9	5
MXS12	M4 X 0.7	2.1	5.5
MXS16	M5 X 0.8	4.4	6
MXS20	M5 X 0.8	4.4	10
MXS25	M6 X 1	7.4	13

- ① The positioning hole on the table and the positioning hole at the bottom of the body do not have the same center. Use these holes during reinstallation after the table has been removed for the maintenance of an identical product.

Environment

⚠ Caution

- ① Do not use in atmosphere where the actuator contacts directly the liquid such as cutting oil.

Conditions where the cylinder piston rod and guide shafts are exposed directly to cutting oil, coolant and oil mist lead to vibration, increase of moving part resistance, air leakage, etc.

- ② Do not use in atmosphere where the actuator contacts directly the material such as powder dust, dust, spatter etc.

This causes vibration, increase of moving part and air leakage. Consult SMC when the use in such environment is required.

- ③ Do not use in direct sun light.

- ④ Do not use in environment where there is heat source.

Use a cover when there is a heat source around the actuator, or if temperature of product increases and exceeds operating temperature range by emissive heat.

- ⑤ Do not subject it to excessive vibration and/or impact.

This results in damage and/or malfunction. Contact SMC if the actuator is used in the above conditions.

Precautions for Adjuster Option

Stroke adjuster

⚠ Caution

- ① Never replace the original adjuster bolts.

Impact energy causes play, damage, etc.

- ② Refer to the below table for lock nut tightening torque.

If the lock nut is not tightened sufficiently, it leads to low positioning accuracy.

Model	Tightening torque (Nm)
MXS 6	3.0
MXS 8	5.0
MXS12	12.5
MXS16	25.0
MXS20	43.0
MXS25	69.0

Precautions for Adjuster Option

Stroke adjuster

⚠ Caution

- ③ When stroke adjuster is adjusted, do not hit the table with the wrench.

This can cause excessive play.

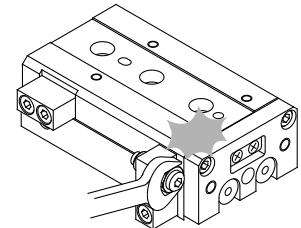

With shock absorber

⚠ Caution

- ① Do not rotate the screw set on bottom of shock absorber.

This is not the screw for adjusting. If this screw is rotated, it may cause oil leakage.

- ② Do not scratch the exposed portion of the piston rod.

Decrease in life or malfunction may result.

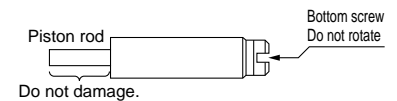

- ③ Shock absorber is considered a consumable component. When energy absorption is decreased, replace it.

Model	Part No. of shock absorber
MXS 8	RB0805
MXS12	RB0806
MXS16	RB1007
MXS20	RB1411
MXS25	RB1412

- ④ Refer to the below table for tightening torque for lock nut of shock absorber.

Model	Tightening torque (Nm)
MXS 8 MXS12	1.67
MXS16	3.14
MXS20 MXS25	10.8



Series MXS/Precautions^③

Be sure to read before handling.

Refer to p.0-39 to 0-43 for Safety Instructions and actuator precautions.

Precautions on Functional Option

With end lock

⚠ Caution

- ① 2 position, 4 or 5 port solenoid valves are recommended.

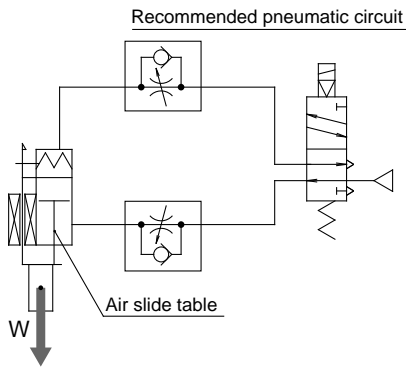

- ② Be sure to use meter-out speed control valves.
- ③ When releasing the end lock manually, be sure that air pressure is released. If the end lock is disengaged while air pressure remains in the cylinder, the piston could lurch suddenly, causing damage to the workpiece.

How to release end lock

* Prior to work, be sure that air pressure is released.

- ① Push down the lock piston pin.
- ② Slide the table forward.

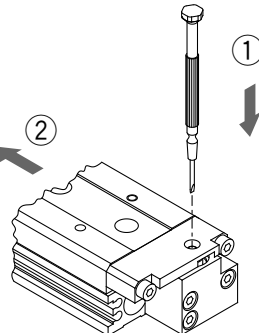

With buffer mechanism

⚠ Caution

- ① When mounting the air slide table with buffer it must be oriented as shown in the sketch below.

When mounting horizontally, operation of the buffer is dependent on the speed and the load. Auto switch should be set according to the buffer stroke used, subject to the speed and load.

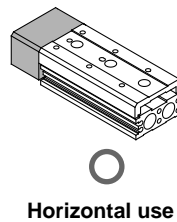
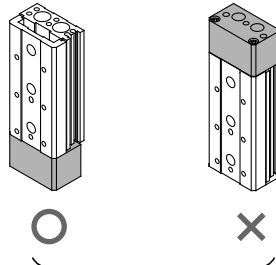

- ② Auto switch for buffer/Correct mounting position for detection at the end of stroke.

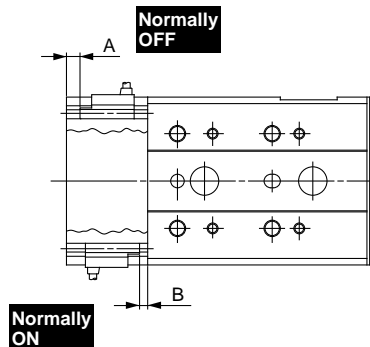

* Adjust the switch position according to load and speed.

(Unit: mm)

Model	A	B
MXS 6	2	3
MXS 8	2.5	
MXS12	4	
MXS16	5	
MXS20	5.5	
MXS25	10	

CL

MLGC

CNA

CB

CV/MVG

CXW

CXS

CXT

MX

MXU

MXS

MXQ

MXF

MXW

MXP

MG

MGP

MGQ

MGG

MGC

MGF

CY1

MY1

Air Slide Table

Series *MXS*

How to Order

Air slide table

MXS 12 — **50** — — — **F9N S**

Bore size (Stroke mm)

6	10, 20, 30, 40, 50
8	10, 20, 30, 40, 50, 75
12	10, 20, 30, 40, 50, 75, 100
16	10, 20, 30, 40, 50, 75, 100, 125
20	10, 20, 30, 40, 50, 75, 100, 125, 150
25	10, 20, 30, 40, 50, 75, 100, 125, 150

Stroke adjuster option

—	Without adjuster
AS	Adjuster at extension end
AT	Adjuster at retraction end
A	Adjuster at both ends
BS⁽¹⁾	Absorber at extension end
BT⁽¹⁾	Absorber at retraction end
B⁽¹⁾	Absorber at both ends

Note 1) Shock absorber is not available for series MXS6.

Number of auto switches

—	2
S	1
n	n

Auto switch

—	Without auto switch
---	---------------------

* Refer to below table for parts No. of auto switch.

Functional option

—	Standard
F	With buffer
R⁽²⁾	With end lock
P	Axial piping
FR⁽²⁾	With buffer, end lock
FP	With buffer, axial piping

Note 2) End lock option is not available for series MXS6.

Combination of Options

○: Possible X: Not possible

Functional option / Adjuster option	Functional option					
	—	F	R	P	FR	FP
—	○	○	○	○	○	○
AS	○	○ ⁽³⁾	○	○	○ ⁽³⁾	○ ⁽³⁾
AT	○	○	X	X	X	X
A	○	○ ⁽³⁾	X	X	X	X
BS	○	X	○	○	X	X
BT	○	○	X	X	X	X
B	○	X	X	X	X	X

Note 3) For combination of buffer mechanism style and stroke adjuster at extension end style, the buffer stroke is shortened by the adjusted length with the stroke adjuster at extension end.

Applicable Auto Switches/Refer to p.5.3-2 for further information on auto switch.

Style	Special function	Electrical entry	Indicator	Wiring (Output)	Load voltage			Auto switch model		Lead wire (m) ⁽¹⁾		Load		Specification details
					DC	AC	Electrical entry		0.5 (-)	3 (L)	IC circuit	Relay, PLC		
							Perpendicular	In-line						
Reed switch	—	Grommet	No	2 wire	24V	5V, 12V	≤100V	A90V	A90	●	●	—	Relay, PLC	P.5.3-19
						12V	100V	A93V	A93	●	●			
						—	5V	—	A96V	A96	●			
Solid state switch	Diagnostic indication (2 color)	Grommet	Yes	3 wire (NPN)	24V	12V	—	F9NV	F9N	●	●	—	Relay, PLC	P.5.3-39
				3 wire (PNP)				F9PV	F9P	●	●			
				2 wire				F9BV	F9B	●	●			
				3 wire (NPN)				F9NWV	F9NW	●	●			
				3 wire (PNP)				F9PWV	F9PW	●	●			
				2 wire				F9B WV	F9B W	●	●			
				—				—	—	—				

Note 1) Lead wire length 0.5m..... — (Ex.) A93
3m..... L A93L

PLC: Programmable Logic Controller

Air Slide Table *Series MXS*

Specifications



Bore size (mm)	6	8	12	16	20	25
Port size	M3 X 0.5	M5 X 0.8			Rc(PT)1/8	
Fluid	Air					
Action	Double acting					
Operating pressure	0.15 to 0.7MPa					
Proof pressure	1.05MPa					
Ambient and fluid temperature	-10 to 60°C					
Piston speed	50 to 500mm/s					
Cushion	Rubber bumper (Standard, With stroke adjuster) Shock absorber (Option)					
Lubrication	Not required					
Auto switch (Option)	Reed switch (2 wire, 3 wire) Solid state switch (2 wire, 3 wire) 2 color solid state switch (2 wire, 3 wire)					
Stroke length tolerance	+1 ₀ mm					

Option

Stroke adjuster option	With stroke adjuster	Adjuster at extension end (AS)	Adjustable stroke range 0 to 5mm
		Adjuster at retraction end (AT)	
		Adjuster at both ends (A)	
With shock absorber	Absorber at extension end (BS)	Shock absorber is not available for MXS6.	
	Absorber at retraction end (BT)		
	Absorber at both ends (B)		
Functional option	With buffer (F)		End lock is not available for MXS6.
	With end lock (R)		
	Axial piping (P)		



Made to Order Specifications

Refer to p.5.4-89 for "Made to Order Specifications" of series MXS.



* For details of adjuster and functional options, please refer to "Optional specifications" on p.3.11-24 to 3.11-26.

Theoretical Force

The dual rod ensures an output twice that of existing cylinders.

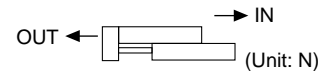

Bore size (mm)	Rod diameter (mm)	Operating direction	Piston area (mm ²)	Operating pressure (MPa)					
				0.2	0.3	0.4	0.5	0.6	0.7
6	3	OUT	57	11	17	23	29	34	40
		IN	42	8	13	17	21	25	29
8	4	OUT	101	20	30	40	51	61	71
		IN	75	15	23	30	38	45	53
12	6	OUT	226	45	68	90	113	136	158
		IN	170	34	51	68	85	102	119
16	8	OUT	402	80	121	161	201	241	281
		IN	302	60	91	121	151	181	211
20	10	OUT	628	126	188	251	314	377	440
		IN	471	94	141	188	236	283	330
25	12	OUT	982	196	295	393	491	589	687
		IN	756	151	227	302	378	454	529

Note) Theoretical force (N)=Pressure (MPa) X Piston area (mm²)

Standard Stroke

Model	Standard stroke (mm)
MXS 6	10, 20, 30, 40, 50
MXS 8	10, 20, 30, 40, 50, 75
MXS12	10, 20, 30, 40, 50, 75, 100
MXS16	10, 20, 30, 40, 50, 75, 100, 125
MXS20	10, 20, 30, 40, 50, 75, 100, 125, 150
MXS25	10, 20, 30, 40, 50, 75, 100, 125, 150

Weight

Model	Standard stroke (mm)									Extra for options						
	10	20	30	40	50	75	100	125	150	Extension adjuster	Retraction adjuster	Extension shock absorber	Retraction shock absorber	Buffer	End lock	Axial piping S: Stroke (mm)
MXS 6	80	100	115	155	180	—	—	—	—	10	5	—	—	30	—	13+0.15S
MXS 8	150	160	190	235	285	415	—	—	—	15	9	35	45	40	40	26+0.17S
MXS12	340	340	340	400	500	690	930	—	—	30	20	50	60	80	90	43+0.21S
MXS16	600	600	610	670	800	1150	1450	1800	—	50	30	80	105	120	160	55+0.21S
MXS20	1000	1020	1050	1150	1300	1700	2250	2800	3350	100	71	170	205	140	310	166+0.45S
MXS25	1720	1740	1750	1900	2160	2750	3400	4300	4900	150	125	215	300	240	540	240+0.45S

CL

MLGC

CNA

CB

CV/MVG

CXW

CXS

CXT

MX

MXU

MXS

MXQ

MXF

MXW

MXP

MG

MGP

MGQ

MGG

MGC

MGF

CY1

MY1

Series MXS

Table Deflection

Table deflection by pitch moment

Table pitch deflection due to static pitch moment applied at arrow for fully extended stroke of slide table

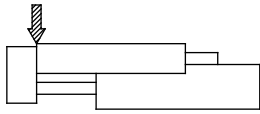

ø6

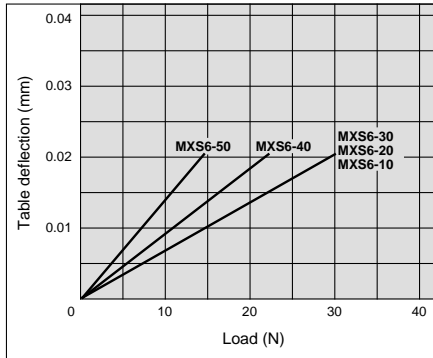

ø8

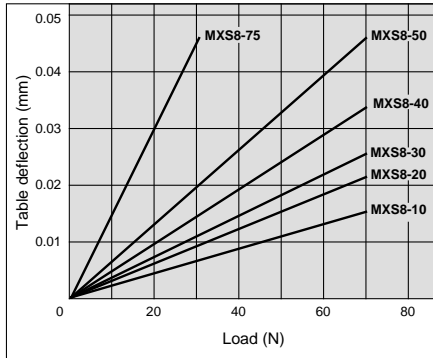

ø12

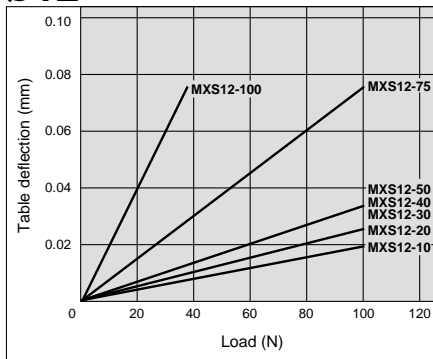
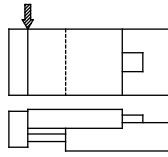
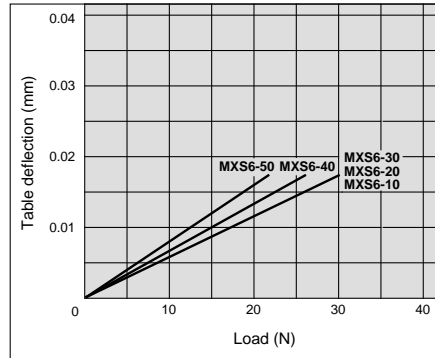

Table deflection by yaw moment

Table yaw deflection due to static yaw moment applied at arrow for fully extended stroke of slide table.



ø6



ø8

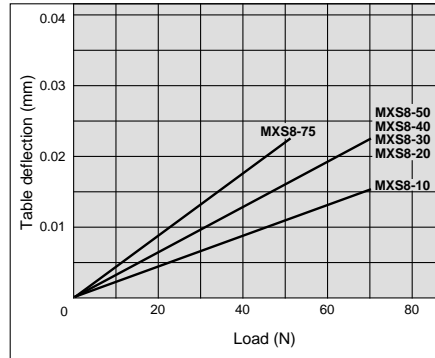

ø12

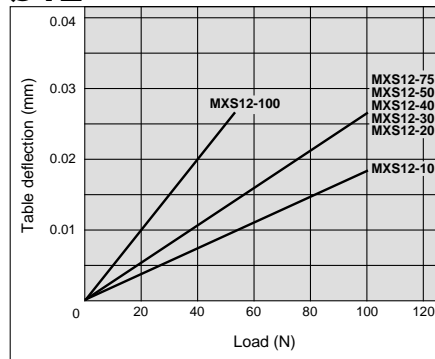
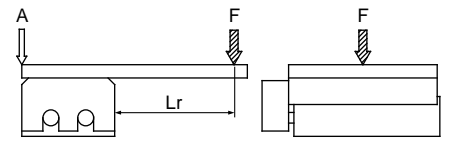
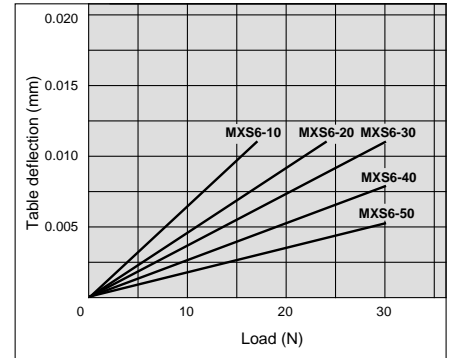

Table deflection by roll moment

Table roll deflection arrow A due to static roll moment applied at arrow F when $L_r =$ (see table) and table is retracted.



ø6



ø8

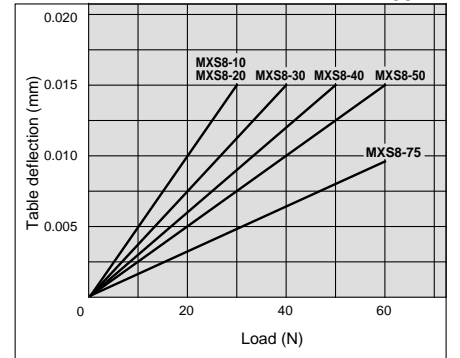

ø12

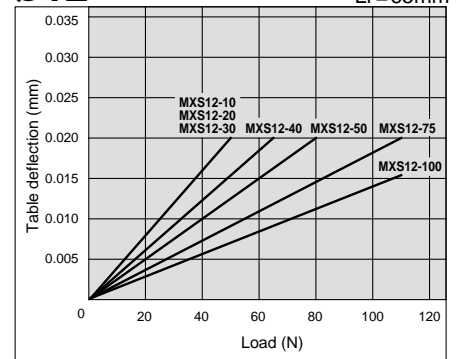
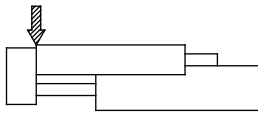
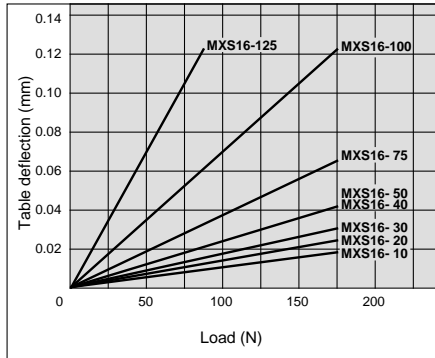

Table deflection by pitch moment

Table pitch deflection due to static pitch moment applied at arrow for fully extended stroke of slide table



ø16



ø20

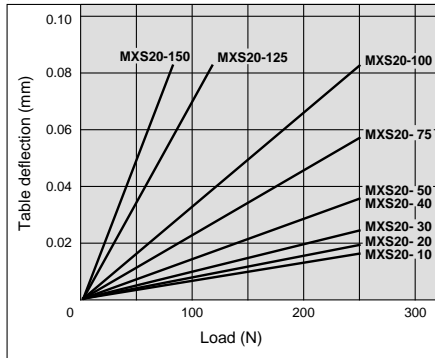

ø25

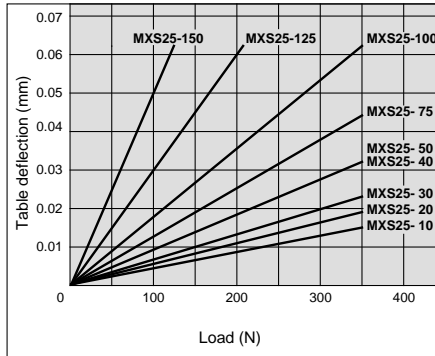
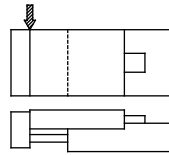
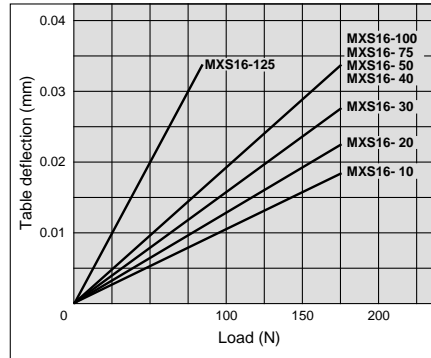

Table deflection by yaw moment

Table yaw deflection due to static yaw moment applied at arrow for fully extended stroke of slide table.



ø16



ø20

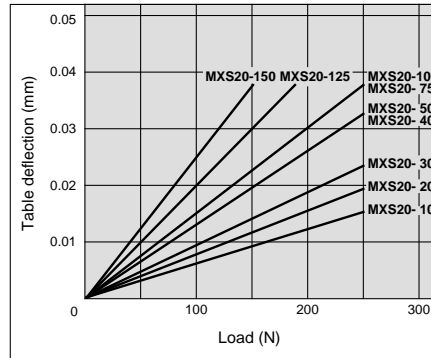

ø25

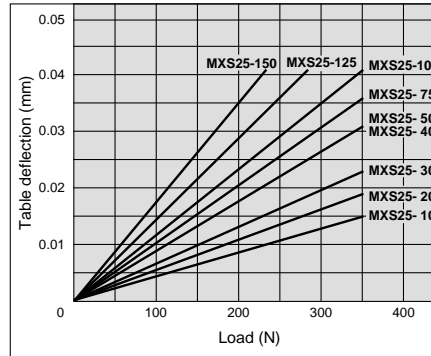
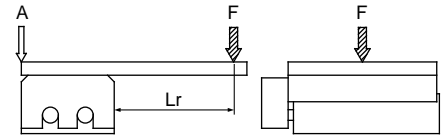
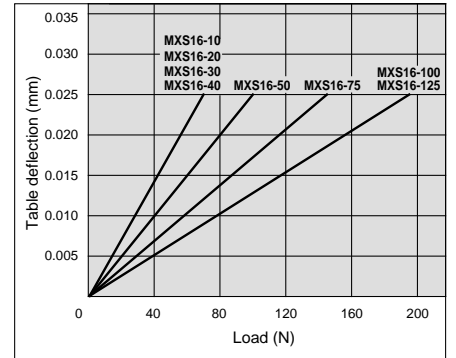

Table deflection by roll moment

Table roll deflection arrow A due to static roll moment applied at arrow F when $L_r =$ (see table) and table is retracted.



ø16



ø20

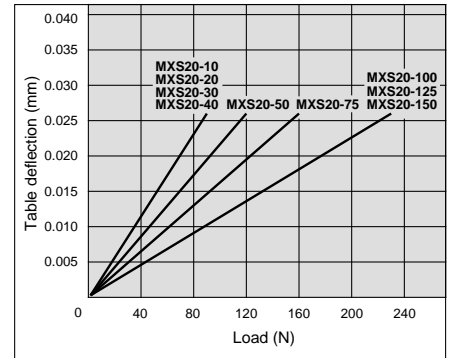

ø25

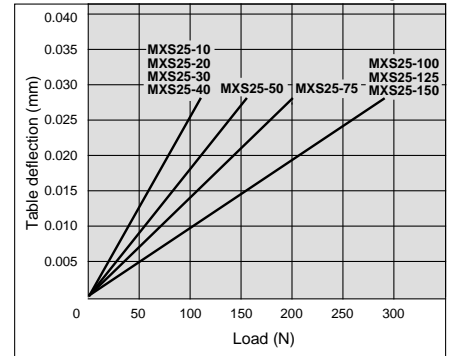

- CL
- MLGC
- CNA
- CB
- CV/MVG
- CXW
- CXS
- CXT
- MX
- MXU
- MXS**
- MXQ
- MXF
- MXW
- MXP
- MG
- MGP
- MGQ
- MGG
- MGC
- MGF
- CY1
- MY1

Series MXS

How to Select

Selection Flow Chart

Formula and Data

Selection Example

1 Operation conditions

Enumerate the operating conditions according to mounting position and work form.

- Model used
- Cushion style
- Work mounting position
- Mounting position
- Average speed Va (mm/s)
- Allowable load W (N): **Fig.1**
- Over hang Ln (mm): **Fig.2**

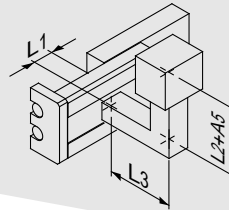

Cylinder: MAX16-15
Cushion: Rubber bumper
Work table mounting
Mounting: Lateral wall mounting
Average speed: Va=300 [mm/s]
Load W=10 [N]
L1=10mm
L2=30mm
L3=30mm

2 Kinetic energy

Calculate kinetic energy E (J) of work.
Calculate allowable kinetic energy Ea (J).
Check that kinetic energy of work does not exceed allowable kinetic energy.

$$E = \frac{1}{2} \cdot \frac{W}{9.8} \left(\frac{V}{1000} \right)^2$$

Collision speed $V=1.4 \cdot Va$
*) Corrected coefficient

$$Ea = K E_{max}$$

Work mounting coefficient K: **Fig.3**
Max. allowable kinetic energy E_{max} : **Table 1**
Kinetic energy (E) ≤ Allowable kinetic energy (Ea)

$$E = \frac{1}{2} \cdot 1 \cdot \left(\frac{420}{1000} \right)^2 = 0.088$$

$$V = 1.4 \times 300 = 420$$

$$Ea = 1 \cdot 0.11 = 0.11$$

Possible to use by $E=0.0$

3 Load rate

3-1 Load rate of work

Calculate static work Wa (N)
Calculate load rate α_1 of static work.

$$Wa = K \beta W_{max}$$

Work mounting coefficient K: **Fig.3**
Allowable load coefficient β : **Graph 1**
Max. Allowable moment W_{max} : **Table 2**
 $\alpha_1 = W/Wa$

$$Wa = 1 \times 1 \times 4 = 4$$

$$K = 1$$

$$\beta = 1$$

$$W_{max} = 4$$

$$\alpha_1 = 1/4 = 0.25$$

3-2 Load rate of static moment

Calculate static moment Me (Nm).
Calculate allowable static moment Ma (Nm)
Calculate load rate α_2 of static moment.

$$M = W(Ln + An)/1000$$

Corrected value for center position distance of moment An: **Table 3**

$$Ma = K \gamma M_{max}$$

Work mounting coefficient K: **Fig.3**
Allowable moment coefficient γ : **Graph 2**
Max. allowable moment M_{max} : **Table 4**
 $\alpha_2 = M / Ma$

Yawing	Rolling
Examine My $My = 1 \times 9.8(10+30)/1000 = 0.39$ A3=30 May=1 X 1 X 15.9=15.9 Mymax=15.9 K=1 $\gamma=1$ $\alpha_2 = 0.39/15.9 = 0.025$	Examine My $My = 1 \times 9.8(10+30)/1000 = 0.39$ A6=10 Mar=15.9(Same value as May) $\alpha_2' = 0.39/15.9 = 0.025$

3-3 Load rate of kinetic moment

Calculate kinetic moment Me (Nm).
Calculate allowable kinetic moment Mea (Nm).
Calculate load rate α_3 of kinetic moment.

$$Me = 1/3 We \times 9.8 \frac{(Ln+An)}{1000}$$

Collision equivalence load $We = \delta \cdot W \cdot V$
 δ : Dumper coefficient
With urethane bumper (Standard) = 4/100
With shock sbsorber=1/100
Corrected value for center position distance of moment An: **Table 3**

$$Mea = K \gamma M_{max}$$

Work mounting coefficient K: **Fig 3**
Allowable moment coefficient γ : **Graph 2**
Max. allowable moment M_{max} : **Table 4**
 $\alpha_3 = Me/Mea$

Pitching	Yawing
Examine Mep $Mep = 1/3 \times 16.8 \times 9.8 \times \frac{(30+10)}{1000} = 2.2$ $We = 4/100 \times 10 \times 420 = 16.8$ A2=10 Meap=1 X 0.7 X 15.9=11.1 K=1 $\gamma=0.7$ Mpmx=15.9 $\alpha_3 = 2.2/11.1 = 0.20$	Examine Mey $Mey = 1/3 \times 16.8 \times 9.8 \times \frac{(30+31)}{1000} = 3.3$ We=168 A4=31 Meay=11.1 (Same value as Meap) $\alpha_3' = 3.3/11.1 = 0.30$

3-4 Sum of load rate

When sum of load rate does not exceed 1, it is possible to use.

$$\sum \alpha_n = \alpha_1 + \alpha_2 + \alpha_3 \leq 1$$

$$\sum \alpha_n = \alpha_1 + \alpha_2 + \alpha_2' + \alpha_3 + \alpha_3' = 0.25 + 0.025 + 0.025 + 0.20 + 0.30 = 0.80 \leq 1$$

And it is possible to use.

Fig.1 Allowable load: W (N)

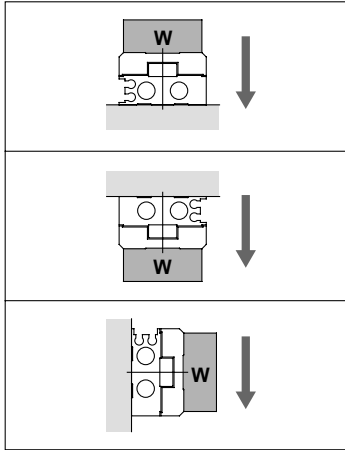

Fig.3 Work mounting coefficient: K

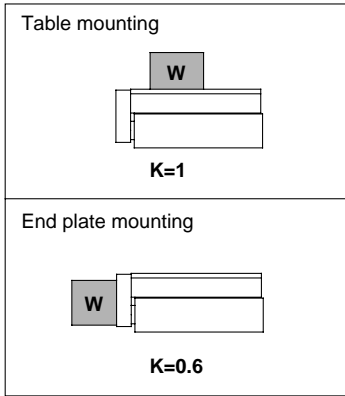

Table 2 Max. allowable static load: W_{max} (kg)

Model	Max. allowable static load
MXS 6	0.6
MXS 8	1
MXS12	2
MXS16	4
MXS20	6
MXS25	9

Table 4 Max. allowable moment: M_{max} (Nm)

Model	Stroke (mm)									
	10	20	30	40	50	75	100	125	150	
MXS 6	0.7	1.0	1.2	1.2	1.2	—	—	—	—	
MXS 8	2.0	2.0	2.8	3.6	4.2	4.2	—	—	—	
MXS12	4.2	4.2	4.2	5.8	7.0	10.0	10.0	—	—	
MXS16	11.3	11.3	11.3	11.3	15.9	25.0	34.1	34.1	—	
MXS20	19.4	19.4	19.4	19.4	27.2	35.0	50.5	50.5	50.5	
MXS25	30.6	30.6	30.6	30.6	42.8	55.1	67.3	67.3	67.3	

Fig.2 Overhang: L_n (mm), Correction value for moment center distance A_n (mm)

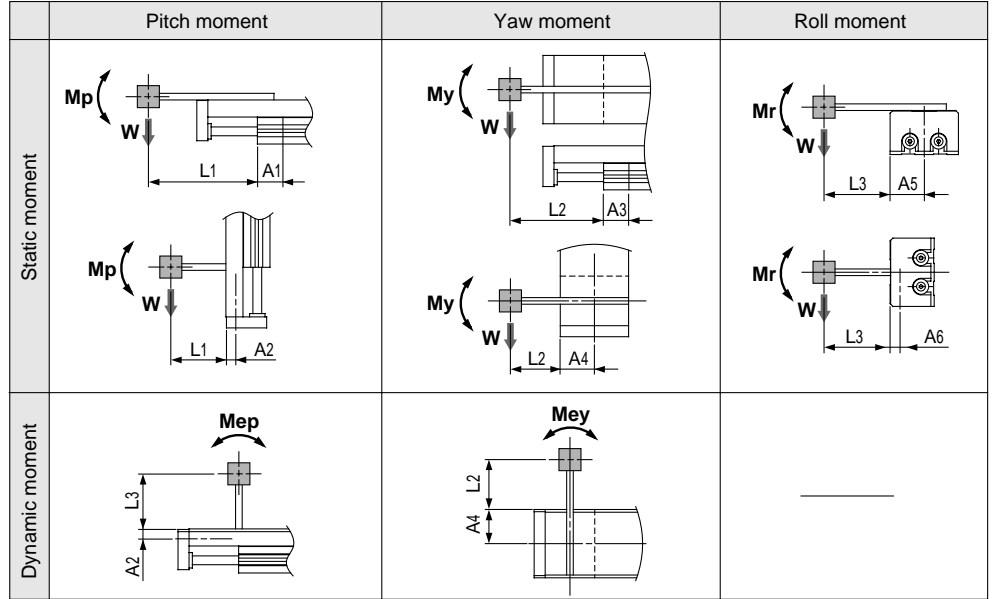

Note) Static moment: Moment by gravity
Kinetic moment: Moment by stopper collision

Table 1 Max. allowable kinetic energy: E_{max} (J)

Model	Allowable kinetic energy	
	Rubber bumper	Shock absorber
MXS 6	0.018	—
MXS 8	0.027	0.045
MXS12	0.055	0.11
MXS16	0.11	0.22
MXS20	0.16	0.32
MXS25	0.24	0.48

Table 3 Correction value for moment center distance A_n (mm)

Model	Correction value for moment center distance (Refer to Fig.2)					
	A1	A2	A3	A4	A5	A6
MXS 6	11	6	13	16	16	6
MXS 8	11	7.5	13	20	20	7.5
MXS12	24	8.5	26	25	25	8.5
MXS16	27	10	30	31	31	10
MXS20	34	14.5	36	38	38	14.5
MXS25	42	19	44	46	46	19

Graph 1 Allowable static load coefficient: β

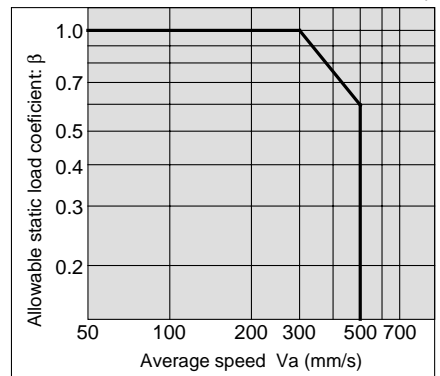

Graph 2 Allowable moment coefficient: γ

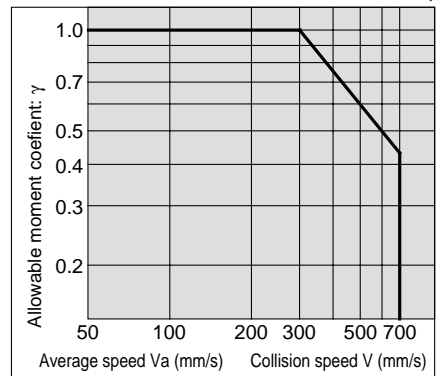

Note) Average speed for static moment
Collision speed for kinetic moment

Symbol

Symbol	Definition	Unit	Symbol	Definition	Unit
A_n (n=1 to 6)	Correction value for moment center distance	mm	V_a	Average speed	mm/s
E	kinetic energy	J	W	Static load	kg
E_a	Allowable kinetic energy	J	W_a	Allowable static load	kg
E_{max}	Max. allowable kinetic energy	J	W_e	Load equivalent to collision	kg
L_n (n=1 to 3)	Over hung	mm	W_{max}	Max. allowable static load	kg
M (M_p, M_y, M_r)	Static moment (Pitch, Yaw, Roll)	Nm	α	Load rate	—
M_a (M_{ap}, M_{ay}, M_{ar})	Allowable static moment (Pitch, Yaw, Roll)	Nm	β	Allowable static load coefficient	—
M_e (M_{ep}, M_{ey})	Kinetic moment (Pitch, Yaw)	Nm	γ	Allowable moment coefficient	—
M_{ea} (M_{eap}, M_{eay})	Allowable kinetic moment (Pitch, Yaw)	Nm	δ	Damper coefficient	—
M_{max} ($M_{pmax}, M_{ymax}, M_{rmax}$)	Max. allowable kinetic moment (Pitch, Yaw, Roll)	Nm	K	Work mounting coefficient	—
V	Collision speed	mm/s			

- CL
- MLGC
- CNA
- CB
- CV/MVG
- CXW
- CXS
- CXT
- MX
- MXU
- MXS**
- MXQ
- MXF
- MXW
- MXP
- MG
- MGP
- MGQ
- MGG
- MGC
- MGF
- CY1
- MY1



Basic style

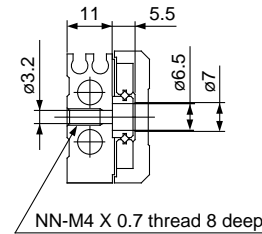
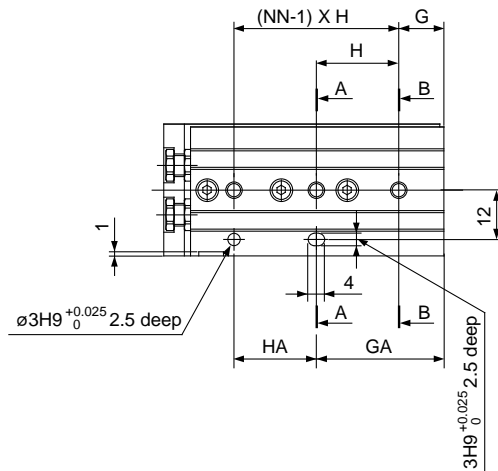
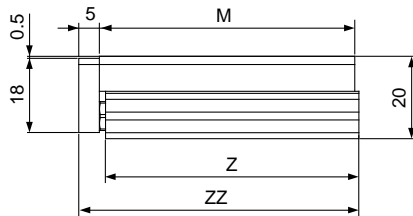
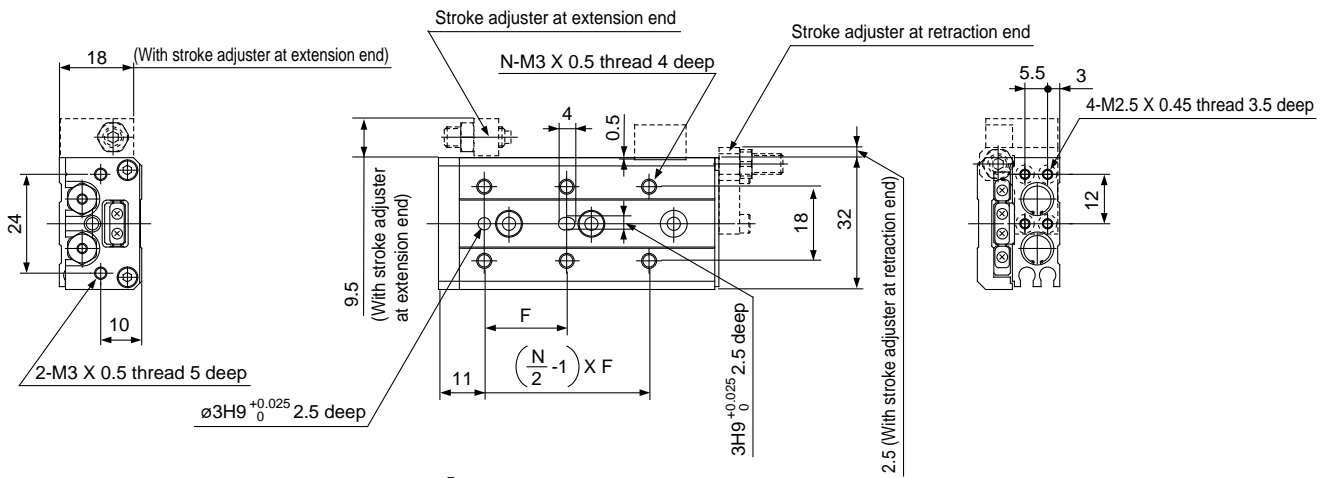
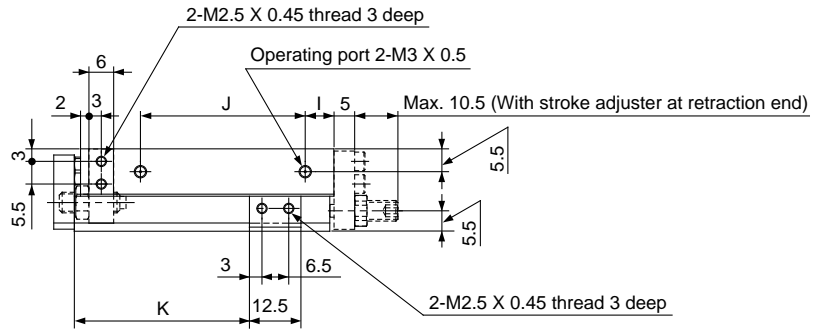

Cross section AA

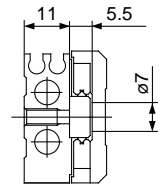

Cross section BB



With auto switch
Basic style

- MXS6-10 SMXS6N, #1
- MXS6-20 SMXS6N, #2
- MXS6-30 SMXS6N, #3
- MXS6-50 SMXS6, #1(#1+#5)

●With stroke adjuster

- MXS6-10AS SMXS6N, #4(#1+#4)
- MXS6-20AS SMXS6N, #5(#2+#5)
- MXS6-30AS SMXS6N, #6(#3+#6+#7)
- MXS6-50AS SMXS6, #2(#1+#2+#5)

Model	F	N	G	H	NN	GA	HA	I	J	K	M	Z	ZZ	(mm)
MXS6-10	20	4	6	25	2	11	20	10	17	22.5	42	41.5	48	
MXS6-20	30	4	6	35	2	21	20	10	27	32.5	52	51.5	58	
MXS6-30	20	6	11	20	3	31	20	7	40	42.5	62	61.5	68	
MXS6-40	28	6	13	30	3	43	30	19	50	52.5	84	83.5	90	
MXS6-50	38	6	17	24	4	41	48	25	60	62.5	100	99.5	106	



With buffer (ø6) MXS6-□□F

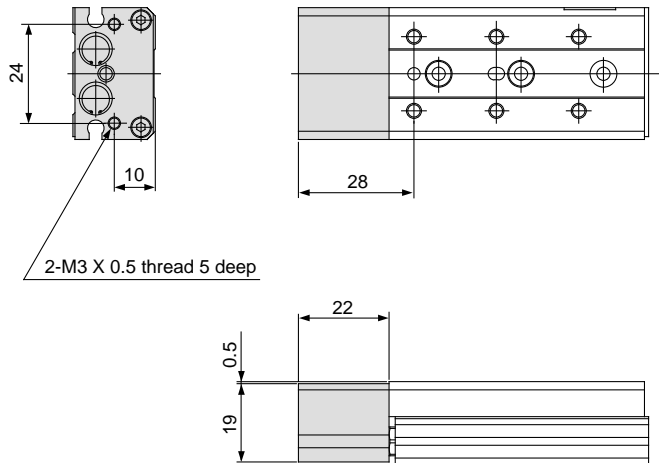

* Dimensions not indicated are the same as the basic style.



MXS6-50F.....SMXS6, #3(#3+#5)

Axial piping (ø6) MXS6-□□P

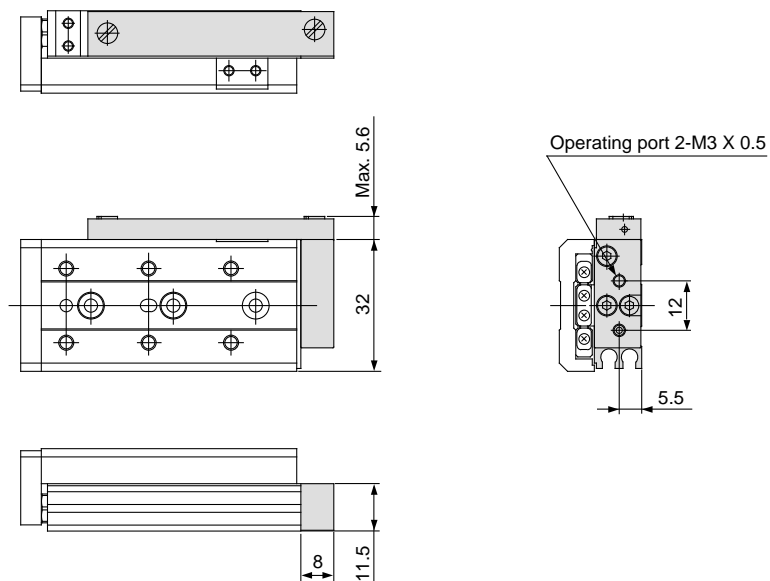

* Dimensions not indicated are the same as the basic style.



MXS6-50P.....SMXS6, #4(#1+#4+#5)

CL
MLGC
CNA
CB
CV/MVG
CXW
CXS
CXT
MX
MXU
MXS
MXQ
MXF
MXW
MPX
MG
MGP
MGQ
MGG
MGC
MGF
CY1
MY1

Basic style

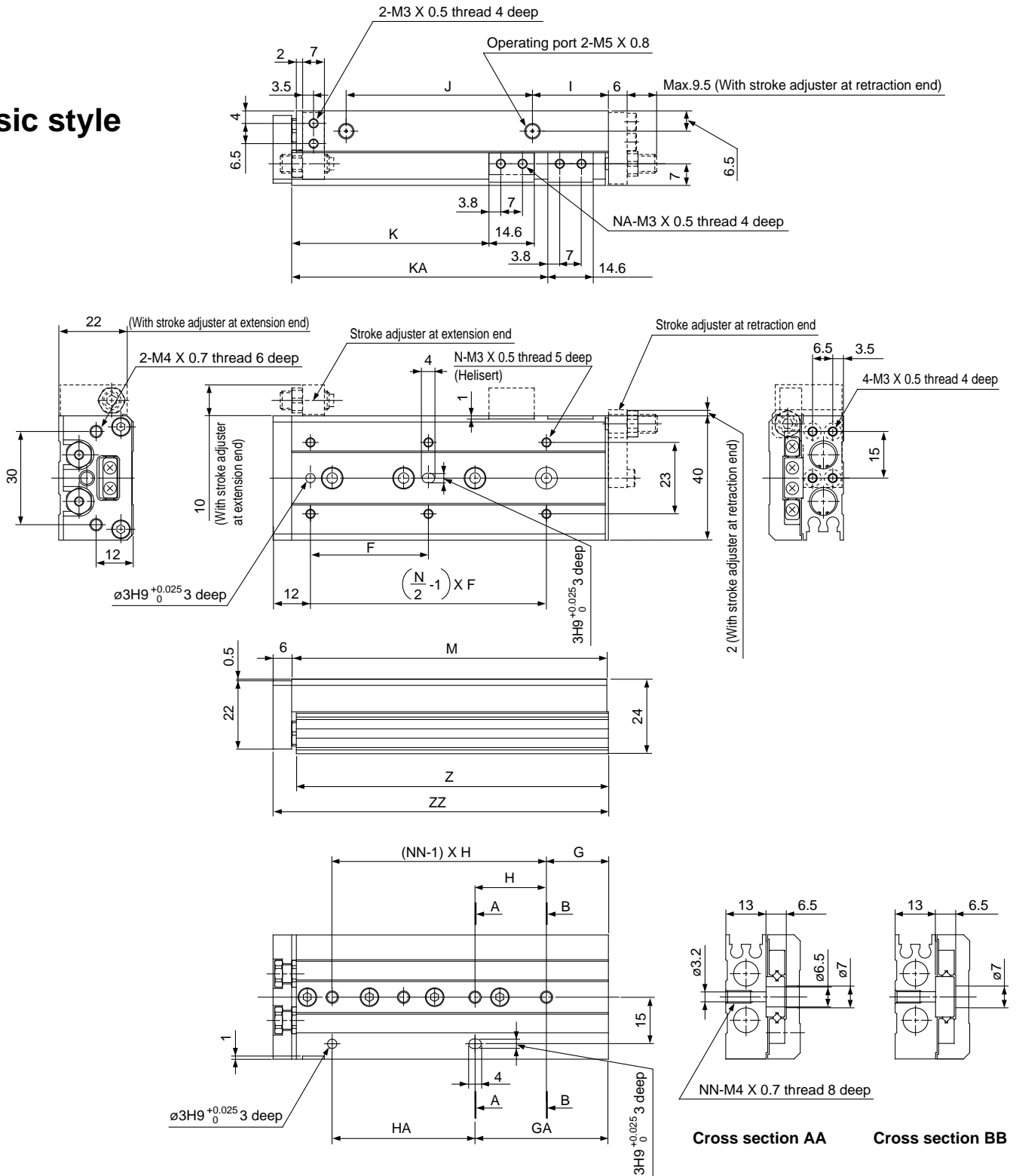

Model	F	N	G	H	NN	GA	HA	I	J	K	KA	NA	M	Z	ZZ
MXS8-10	25	4	9	28	2	17	20	13	19.5	23.5	—	2	49	48.5	56
MXS8-20	25	4	12	30	2	12	30	8.5	29	33.5	—	2	54	53.5	61
MXS8-30	40	4	13	20	3	33	20	9.5	39	43.5	—	2	65	64.5	72
MXS8-40	50	4	15	28	3	43	28	10.5	56	53.5	—	2	83	82.5	90
MXS8-50	38	6	20	23	4	43	46	24.5	60	63.5	82.5	4	101	100.5	108
MXS8-75	50	6	27	28	5	83	56	38.5	96	88.5	132.5	4	151	150.5	158

-  With auto switch
 Basic style
 MXS8-10 SMXS8A, #1
 MXS8-20 SMXS8A, #2
 MXS8-30 SMXS8A, #3(#3+#7)
 MXS8-40 SMXS8B, #1
 MXS8-50 SMXS8B, #2(#2+#5)
 ● With stroke adjuster
 MXS8-10AS SMXS8A, #4(#1+#4)
 MXS8-20AS SMXS8A, #5(#2+#5)
 MXS8-30AS SMXS8A, #6(#3+#6+#7)
 MXS8-40AS SMXS8B, #3(#1+#3)
 MXS8-50AS SMXS8B, #4(#2+#4+#5)



With shock absorber (ø6) MXS8-□□BS, BT, B

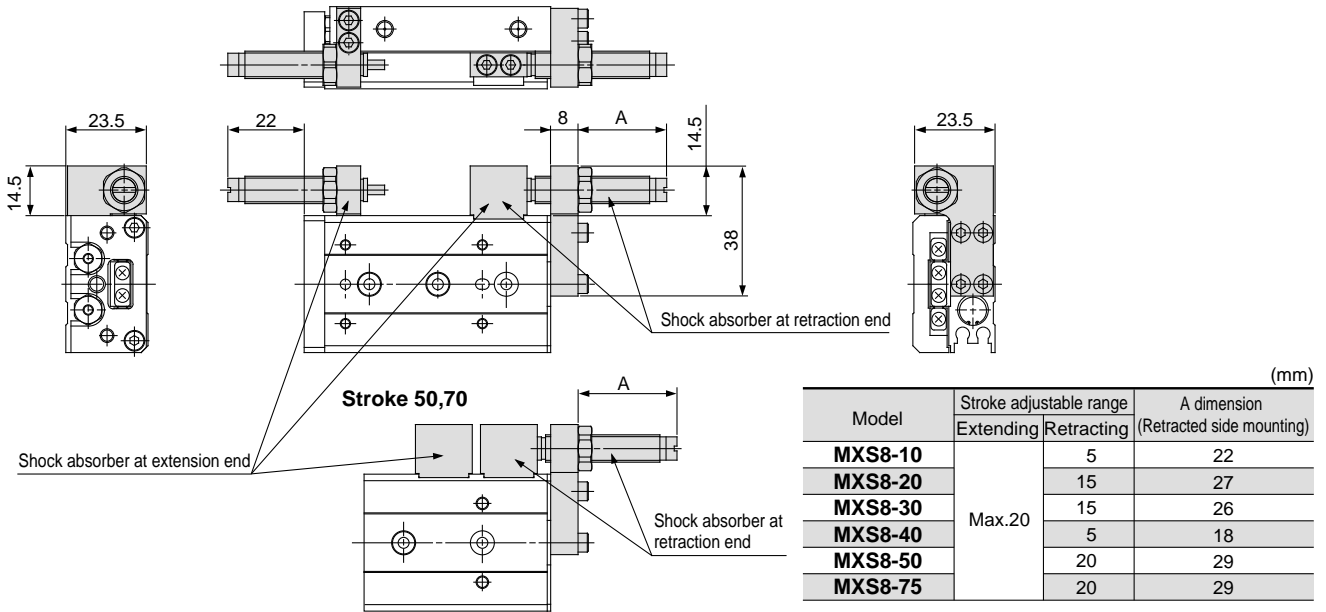

* Dimensions not indicated are the same as the basic style.

With end lock (ø8) MXS8-□□R

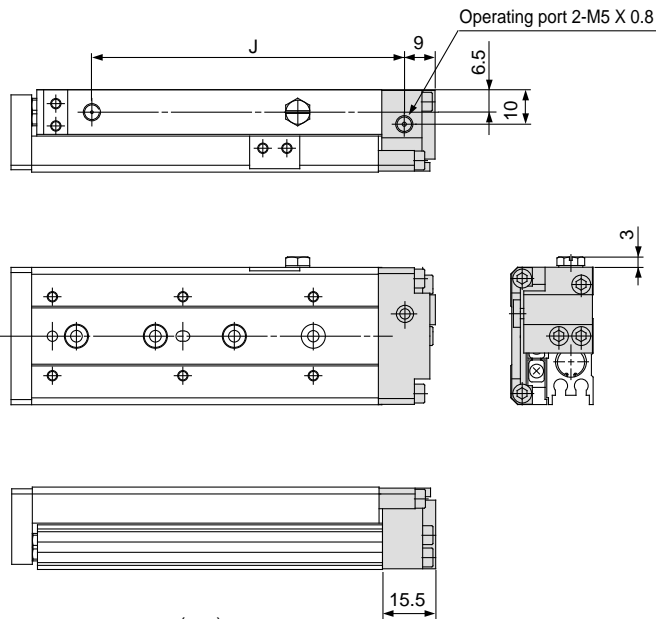

(mm)	
Model	J
MXS8-10R	39
MXS8-20R	44
MXS8-30R	55
MXS8-40R	73
MXS8-50R	91
MXS8-75R	141

* Dimensions not indicated are the same as the basic style.



MXS8-50R SMXS8, #4(#1+#4+#6)

With buffer (ø8) MXS8-□□F

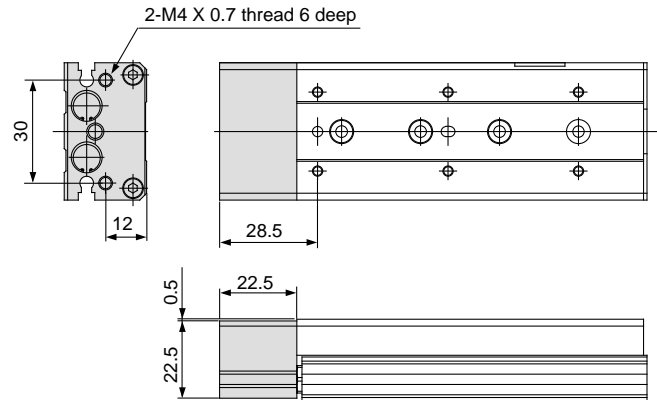

* Dimensions not indicated are the same as the basic style.



MXS8-50F SMXS8, #3

Axial piping (ø8) MXS8-□□P

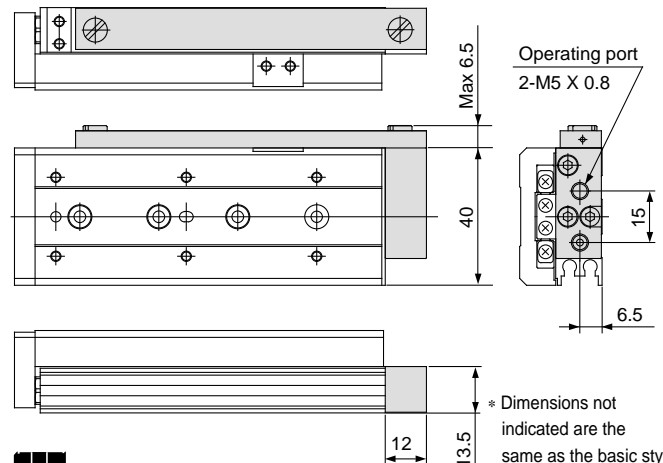

* Dimensions not indicated are the same as the basic style.



MXS8-50P SMXS8, #5(#1+#5+#6)

- CL
- MLGC
- CNA
- CB
- CV/MVG
- CXW
- CXS
- CXT
- MX
- MXU
- MXS
- MXQ
- MXF
- MXW
- MPX
- MG
- MGP
- MGQ
- MGG
- MGC
- MGF
- CY1
- MY1



With shock absorber(ø12) MXS12-□□BS, BT, B

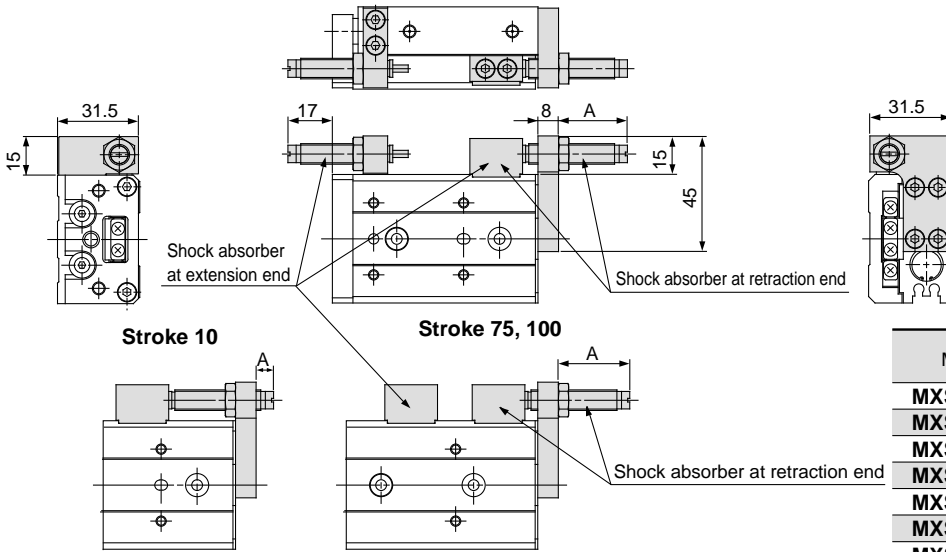

* Other dimensions not indicated are the same as the basic style.

Model	Stroke adjustment range		A dimension (Retracted side mounting)
	Extending	Retracting	
MXS12-10	Max. 20	2	7
MXS12-20		5	17
MXS12-30		15	27
MXS12-40		15	25
MXS12-50		5	15
MXS12-75		15	28
MXS12-100	15	28	

With end lock(ø12) MXS12-□□R

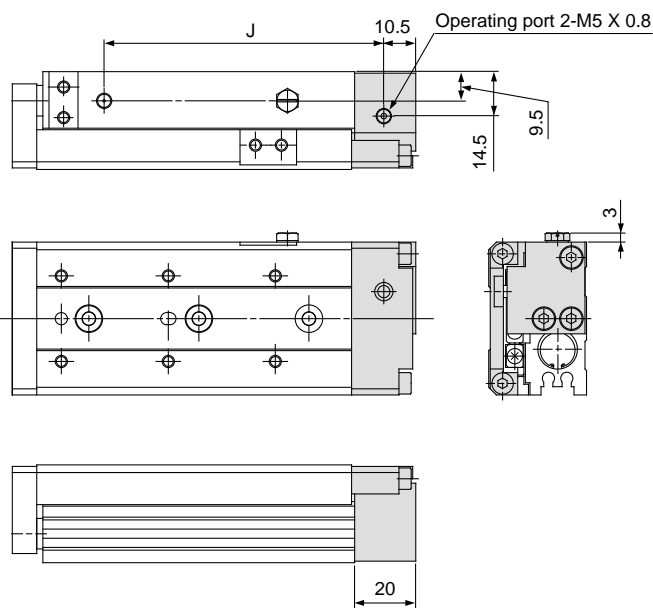

(mm)

Model	J
MXS12-10R	59.5
MXS12-20R	59.5
MXS12-30R	59.5
MXS12-40R	71.5
MXS12-50R	91.5
MXS12-75R	137.5
MXS12-100R	191.5

* Dimensions not indicated are the same as the basic style.

MXS12-50RSMXS12, #4(#1+#4+#6)

With buffer(ø12) MXS12-□□F

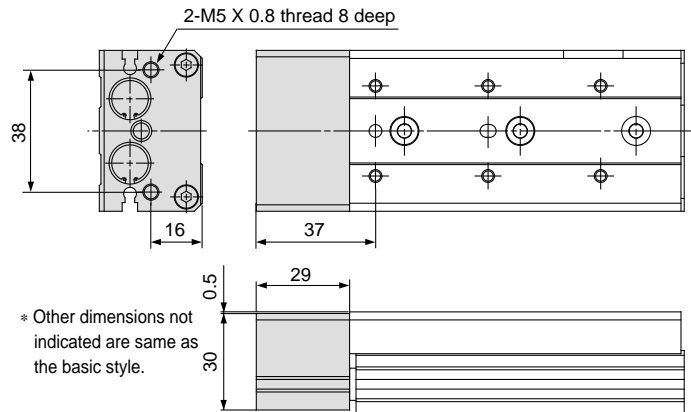

* Other dimensions not indicated are same as the basic style.

MXS12-50F.....SMXS12, (#3+#6)

Axial piping(ø12) MXS12-□□P

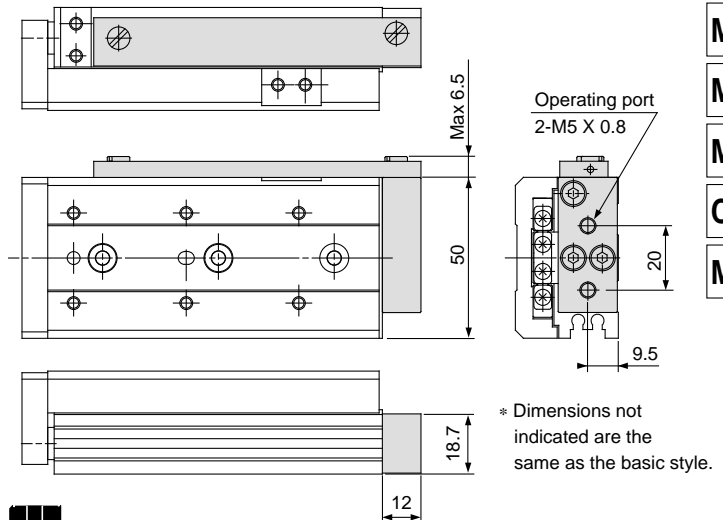

* Dimensions not indicated are the same as the basic style.

MXS12-50P SMXS12, #5(#1+#5+#6)

- CL
- MLGC
- CNA
- CB
- CV/MVG
- CXW
- CXS
- CXT
- MX
- MXU
- MXS**
- MXQ
- MXF
- MXW
- MXP
- MG
- MGP
- MGQ
- MGG
- MGC
- MGF
- CY1
- MY1

Series MXS

Dimensions MXS 16

Basic style

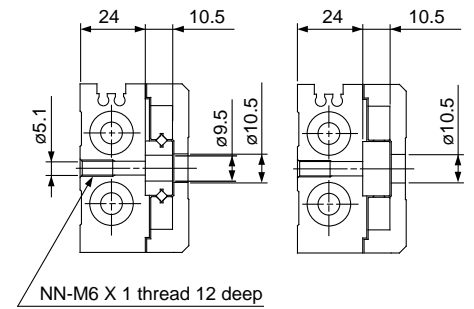
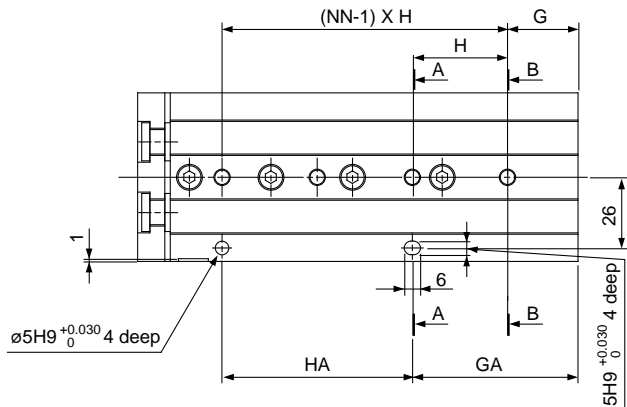
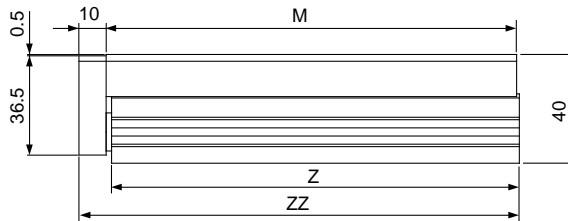
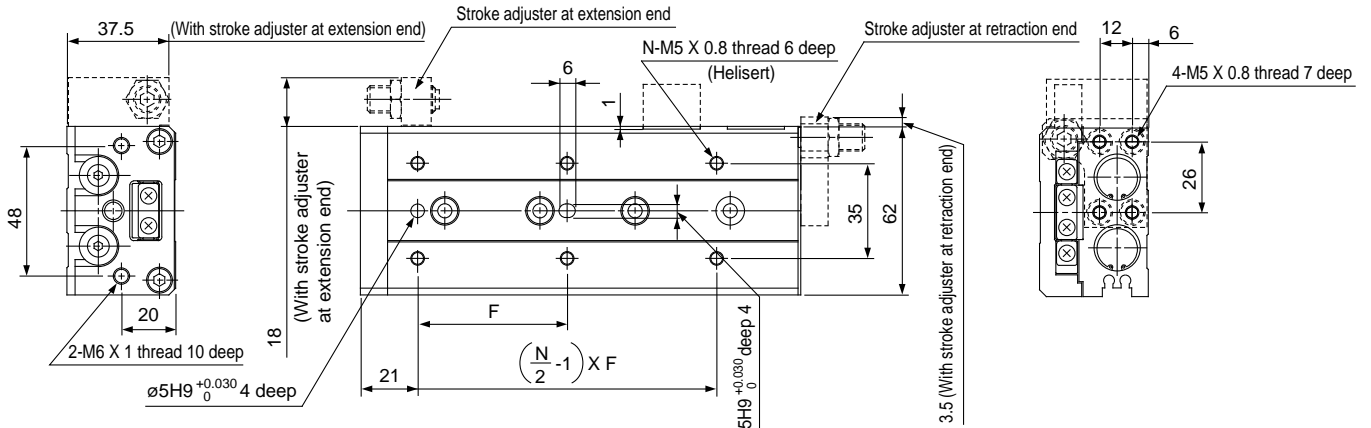
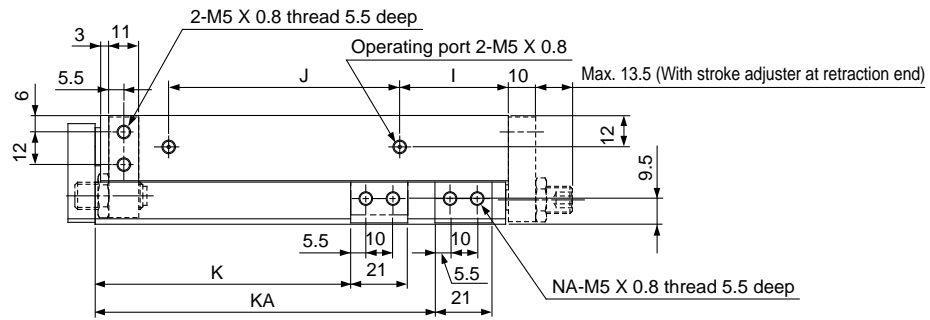

Cross section AA Cross section BB



With auto switch

Basic style

MXS16-10 SMXS16A, #1

MXS16-20 SMXS16A, #2

MXS16-30 SMXS16A, #3

MXS16-40 SMXS16A, #4(#4+#9)

MXS16-50 SMXS16B, #1

MXS16-75 SMXS16B, #2

MXS16-100 SMXS16B, #3(#3+#7)

●With stroke adjuster

MXS16-10AS SMXS16A, #5(#1+#5)

MXS16-20AS SMXS16A, #6(#2+#6)

MXS16-30AS SMXS16A, #7(#3+#7)

MXS16-40AS SMXS16A, #8(#4+#8+#9)

MXS16-50AS SMXS16B, #4(#1+#4)

MXS16-75AS SMXS16B, #5(#2+#5)

MXS16-100AS ... SMXS16B, #6(#3+#6+#7)

Model	F	N	G	H	NN	GA	HA	I	J	K	KA	NA	M	Z	ZZ
MXS16-10	35	4	16	40	2	16	40	10	40	29	—	2	76	75	87
MXS16-20	35	4	16	40	2	16	40	10	40	39	—	2	76	75	87
MXS16-30	35	4	16	40	2	16	40	10	40	49	—	2	76	75	87
MXS16-40	40	4	16	50	2	16	50	10	50	59	—	2	86	85	97
MXS16-50	30	6	21	30	3	51	30	15	60	69	—	2	101	100	112
MXS16-75	55	6	26	35	4	61	70	40	85	94	125	4	151	150	162
MXS16-100	65	6	39	35	5	109	70	55	118	119	173	4	199	198	210
MXS16-125	70	8	19	35	7	159	70	68	155	144	223	4	249	248	260



With shock absorber(ø16) MXS16-□□BS, BT, B

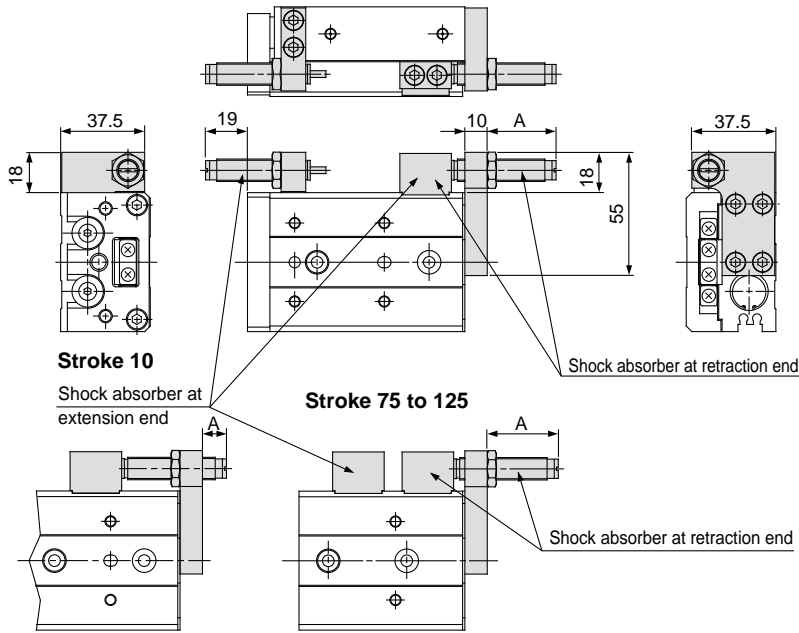

Model	Stroke adjustment range		A dimension (Retracted side mounting)
	Extending	Retracting	
MXS16-10	Max. 25	5	11
MXS16-20		10	21
MXS16-30		20	31
MXS16-40		20	31
MXS16-50		15	26
MXS16-75		20	32
MXS16-100		20	32
MXS16-125		20	32

* Other dimensions not indicated are the same as the basic style.

With end lock(ø16) MXS16-□□R

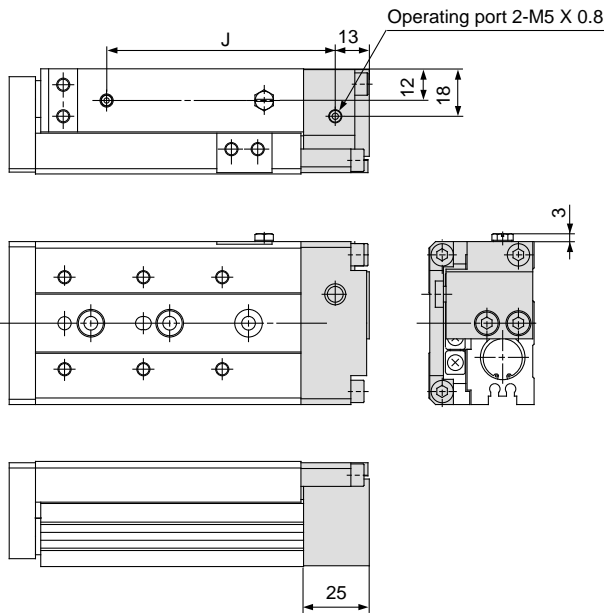

Model	J
MXS16-10R	62
MXS16-20R	62
MXS16-30R	62
MXS16-40R	72
MXS16-50R	87
MXS16-75R	137
MXS16-100R	185
MXS16-125R	235

* Dimensions not indicated are the same as the basic style.

MXS16-50R.....SMXS16, #4(#1+#4+#6)

With buffer(ø16) MXS16-□□F

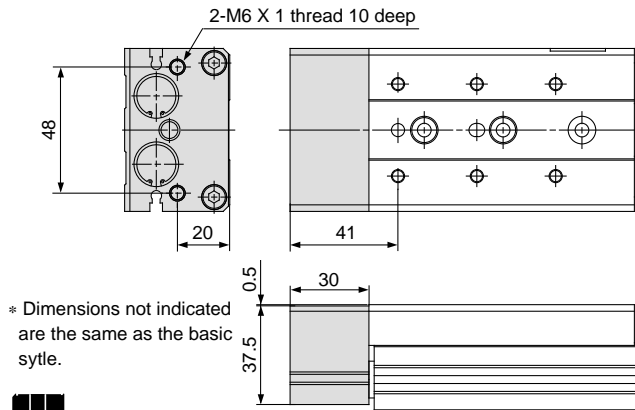

* Dimensions not indicated are the same as the basic style.

MXS16-50F.....SMXS#6, (#3+#6)

Axial piping(ø16) MXS16-□□P

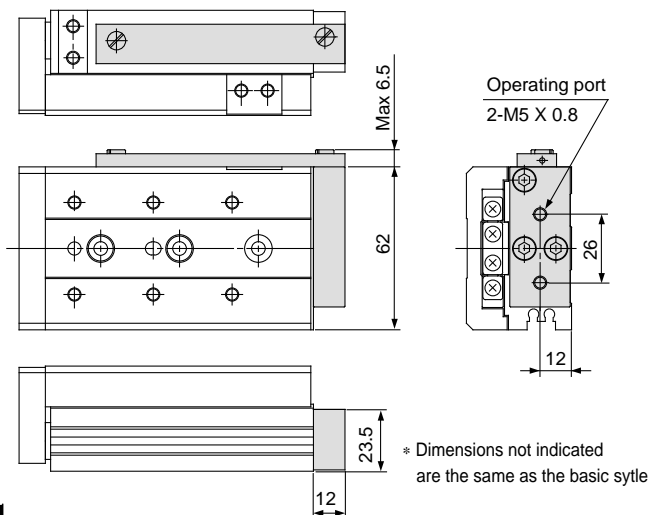

* Dimensions not indicated are the same as the basic style.

MXS16-50P.....SMXS16, #5(#1+#5+#6)

- CL
- MLGC
- CNA
- CB
- CV/MVG
- CXW
- CXS
- CXT
- MX
- MXU
- MXS
- MXQ
- MXF
- MXW
- MXP
- MG
- MGP
- MGQ
- MGG
- MGC
- MGF
- CY1
- MY1

Series MXS

Dimensions MXS 20



Basic style

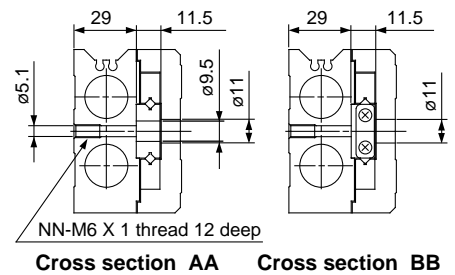
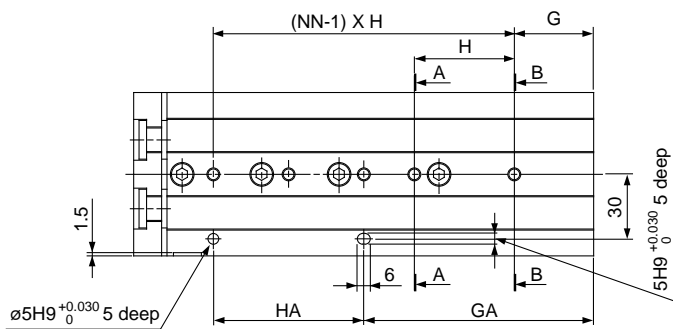
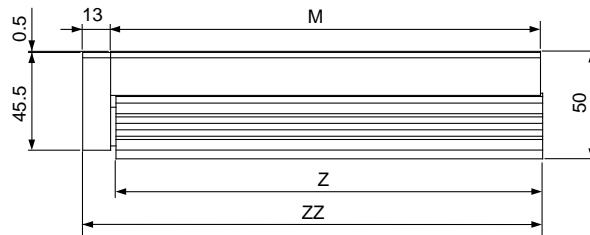
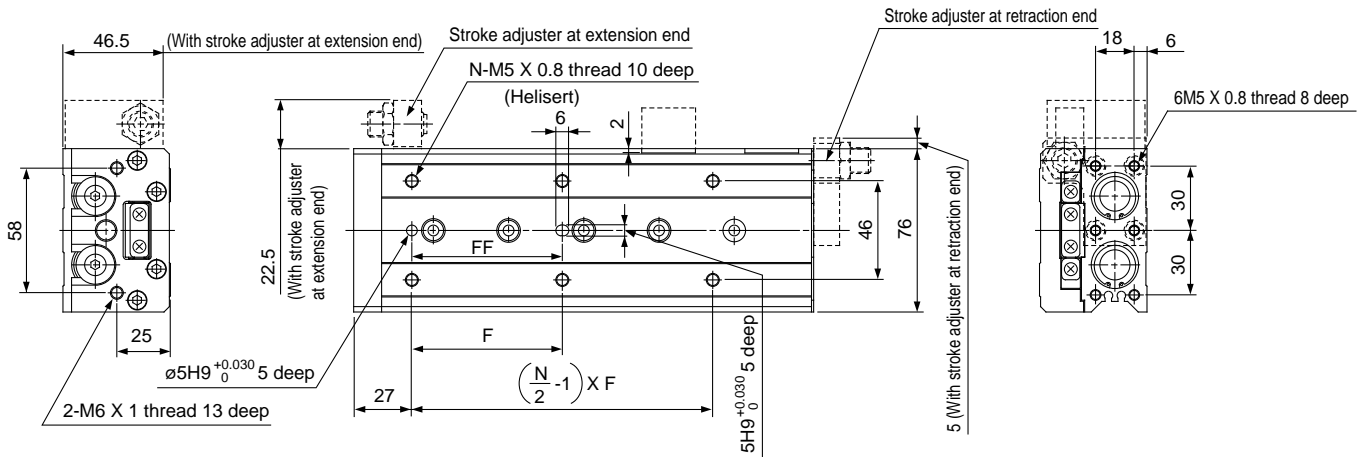
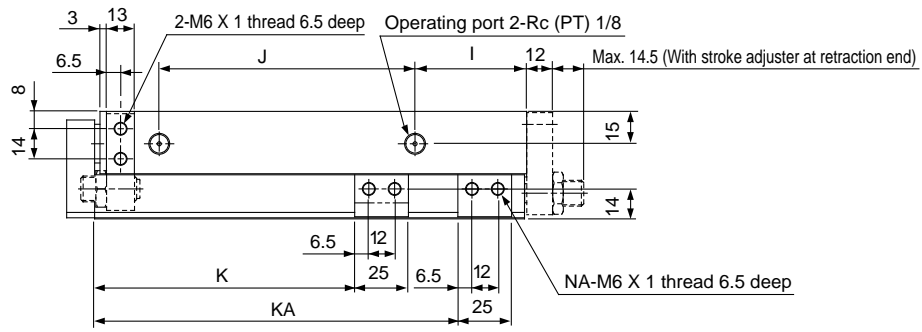

With auto switch

Basic style

- MXS20-10 SMXS20A, #1
- MXS20-20 SMXS20A, #2
- MXS20-30 SMXS20A, #3
- MXS20-40 SMXS20A, #4(#4+#9)
- MXS20-50 SMXS20B, #1
- MXS20-75 SMXS20B, #2
- MXS20-100 SMXS20B, #3(#3+#7)
- With stroke adjuster
- MXS20-10AS SMXS20A, #5(#1+#5)
- MXS20-20AS SMXS20B, #6(#2+#6)
- MXS20-30AS SMXS20A, #7(#3+#7)
- MXS20-40AS SMXS20A, #8(#4+#8+#9)
- MXS20-50AS SMXS20B, #4(#1+#4)
- MXS20-75AS SMXS20B, #5(#2+#5)
- MXS20-100AS SMXS20B, #6(#3+#6+#7)

Model	F	FF	N	G	H	NN	GA	HA	I	J	K	KA	NA	M	Z	ZZ
MXS20-10	50	40	4	15	45	2	25	35	10	44	31	—	2	83	81.5	97
MXS20-20	50	40	4	15	45	2	25	35	10	44	41	—	2	83	81.5	97
MXS20-30	50	40	4	15	45	2	25	35	10	44	51	—	2	83	81.5	97
MXS20-40	60	50	4	15	55	2	35	35	10	54	61	—	2	93	91.5	107
MXS20-50	35	35	6	15	35	3	50	35	10	69	71	—	2	108	106.5	122
MXS20-75	60	60	6	19	35	4	54	70	10	108	96	—	2	147	145.5	161
MXS20-100	70	70	6	37	35	5	107	70	58	113	121	169	4	200	198.5	214
MXS20-125	70	70	8	41	38	6	155	76	70	155	146	223	4	254	252.5	268
MXS20-150	80	80	8	19	44	7	195	88	87	190	171	275	4	306	304.5	320



With shock absorber(ø20) MXS20-□□BS, BT, B

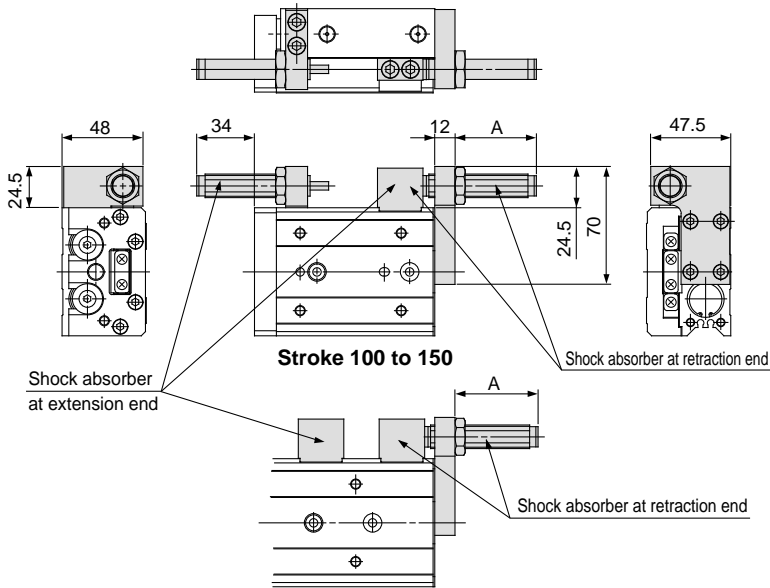

* Dimensions not indicated are the same as the basic style.

Model	Stroke adjustable range		A dimension (Retracted side mounting)
	Extending	Retracting	
MXS20-10	Max. 40	5	28
MXS20-20		15	38
MXS20-30		25	48
MXS20-40		35	48
MXS20-50		30	43
MXS20-75		15	29
MXS20-100		35	49
MXS20-125		35	49
MXS20-150		35	49

With end lock(ø20) MXS20-□□R

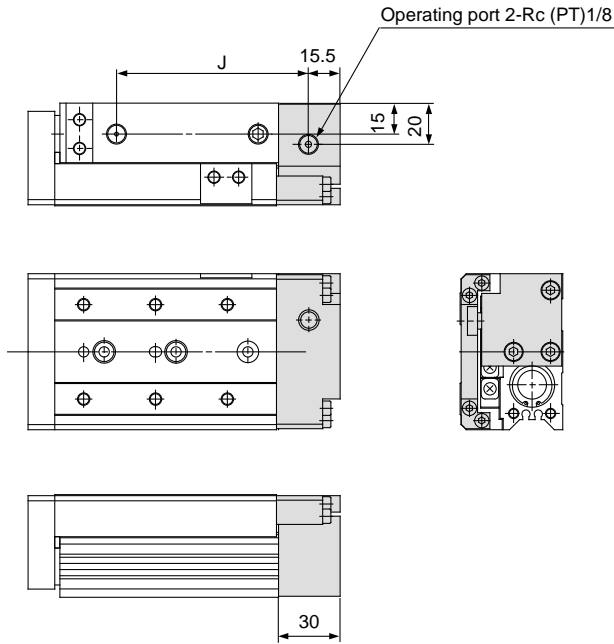

Model	J
MXS20-10R	68.5
MXS20-20R	68.5
MXS20-30R	68.5
MXS20-40R	78.5
MXS20-50R	93.5
MXS20-75R	132.5
MXS20-100R	185.5
MXS20-125R	239.5
MXS20-150R	291.5

* Dimensions not indicated are the same as the basic style.

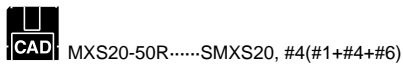

With buffer(ø20) MXS20-□□F

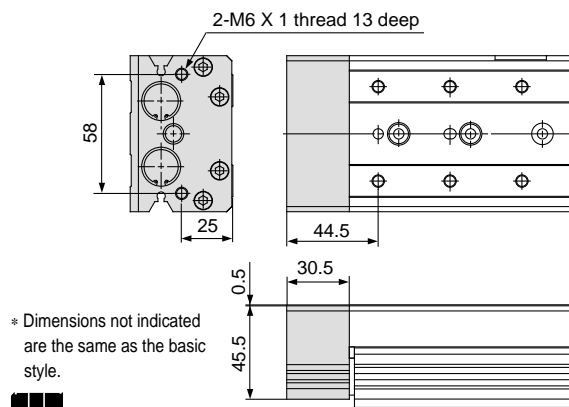

* Dimensions not indicated are the same as the basic style.

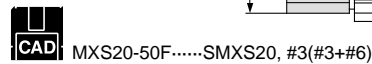

Axial piping(ø20) MXS20-□□P

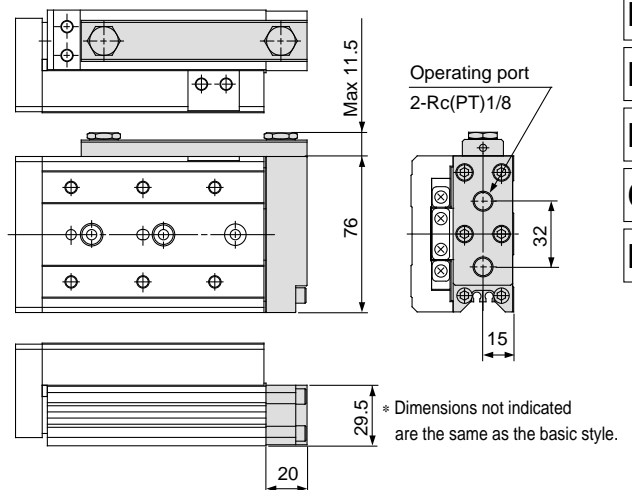

* Dimensions not indicated are the same as the basic style.

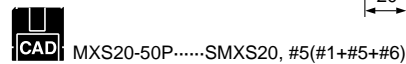

- CL
- MLGC
- CNA
- CB
- CV/MVG
- CXW
- CXS
- CXT
- MX
- MXU
- MXS**
- MXQ
- MXF
- MXW
- MXP
- MG
- MGP
- MGQ
- MGG
- MGC
- MGF
- CY1
- MY1

Series MXS

Dimensions MXS 25



Basic style

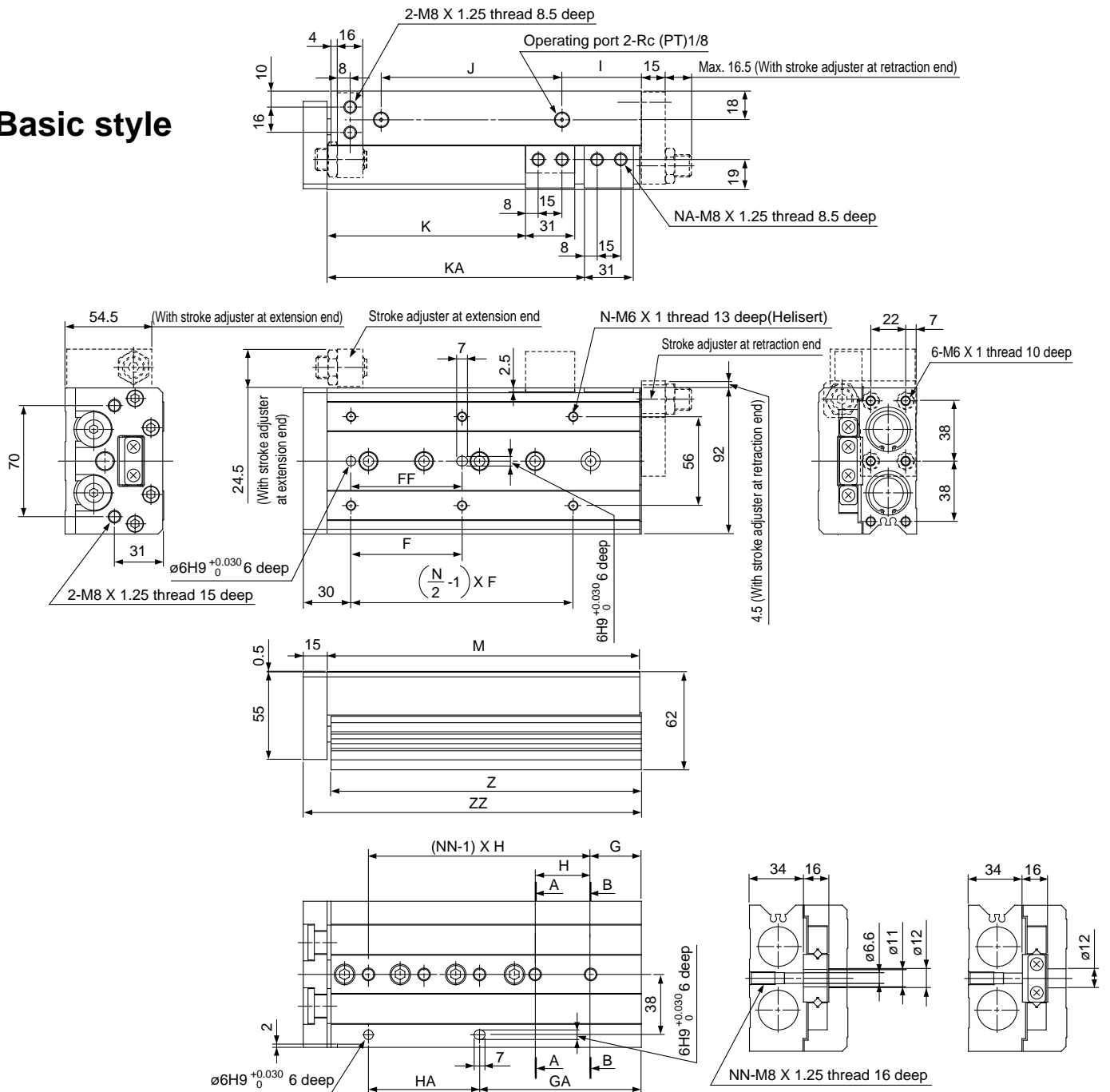

Cross section AA

Cross section BB



With auto switch
Basic style

- MXS25-10 SMXS25A, #1
- MXS25-20 SMXS25A, #2
- MXS25-30 SMXS25A, #3
- MXS25-40 SMXS25A, #4(#4+#9)
- MXS25-50 SMXS25B, #1
- MXS25-75 SMXS25B, #2
- MXS25-100 SMXS25B, #3(#3+#7)
- With stroke adjuster
- MXS25-10AS.....SMXS25A, #5(#1+#5)
- MXS25-20AS.....SMXS25A, #6(#2+#6)
- MXS25-30AS.....SMXS25A, #7(#3+#7)
- MXS25-40AS.....SMXS25A, #8(#4+#8+#9)
- MXS25-50AS.....SMXS25B, #4(#1+#4)
- MXS25-75AS.....SMXS25B, #5(#2+#5)
- MXS25-100AS... SMXS25B, #6(#3+#6+#7)

Model	F	FF	N	G	H	NN	GA	HA	I	J	K	KA	NA	M	Z	ZZ
MXS25-10	50	40	4	22	45	2	22	45	12	47	35	—	2	92	90.5	108
MXS25-20	50	40	4	22	45	2	22	45	12	47	45	—	2	92	90.5	108
MXS25-30	50	40	4	22	45	2	22	45	12	47	55	—	2	92	90.5	108
MXS25-40	60	50	4	22	55	2	22	55	12	57	65	—	2	102	100.5	118
MXS25-50	35	35	6	20	35	3	55	35	12	70	75	—	2	115	113.5	131
MXS25-75	60	60	6	26	35	4	61	70	33	90	100	—	2	156	154.5	172
MXS25-100	70	70	6	32	35	5	102	70	50	114	125	162	4	197	195.5	213
MXS25-125	75	75	8	40	38	6	154	76	67	155	150	218	4	255	253.5	271
MXS25-150	80	80	8	30	40	7	190	80	82	180	175	258	4	295	293.5	311



With shock absorber(ø25) MXS25-□□BS, BT, B

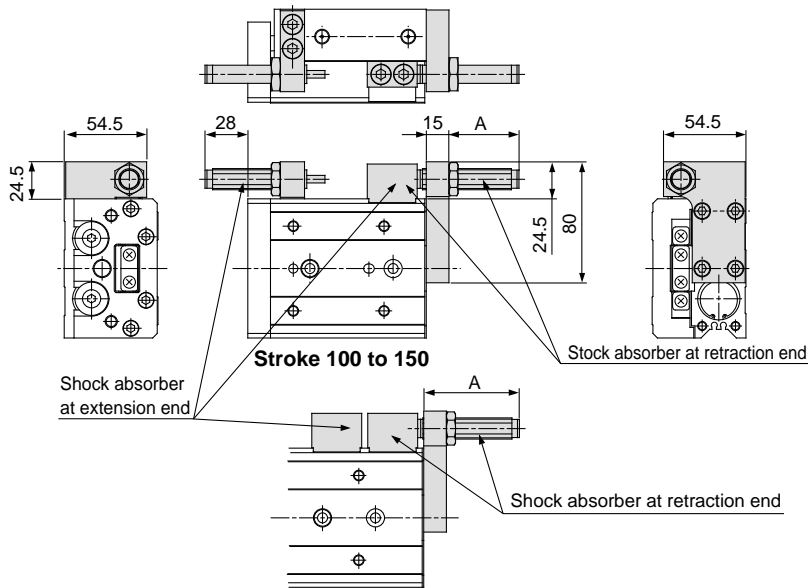

Model	Stroke adjustable range		A dimension (Retracted side mounting)
	Extending	Retracting	
MXS25-10	Max. 35	5	26
MXS25-20		15	36
MXS25-30		25	46
MXS25-40		35	46
MXS25-50		30	43
MXS25-75		15	27
MXS25-100		35	48
MXS25-125		35	46
MXS25-150		35	46

* Dimensions not indicated are the same as the basic style.

With end lock(ø25) MXS25-□□R

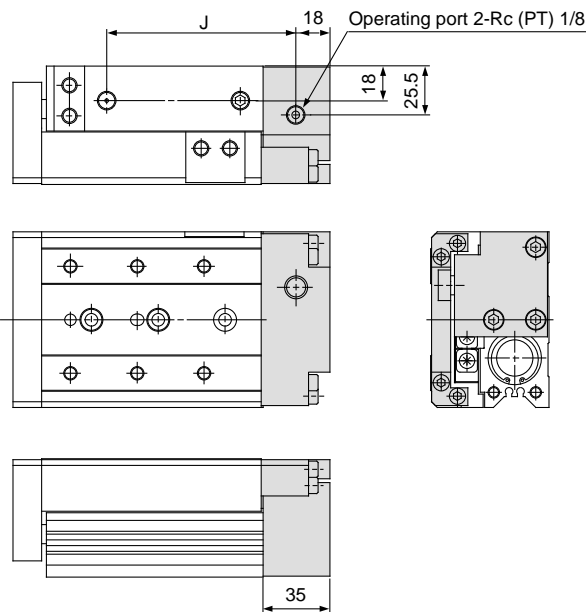

Model	J
MXS25-10R	76
MXS25-20R	76
MXS25-30R	76
MXS25-40R	86
MXS25-50R	99
MXS25-75R	140
MXS25-100R	181
MXS25-125R	239
MXS25-150R	279

* Dimensions not indicated are the same as the basic style.



MXS25-50R.....SMXS25, #4(#1+#4+#6)

With buffer(ø25) MXS25-□□F

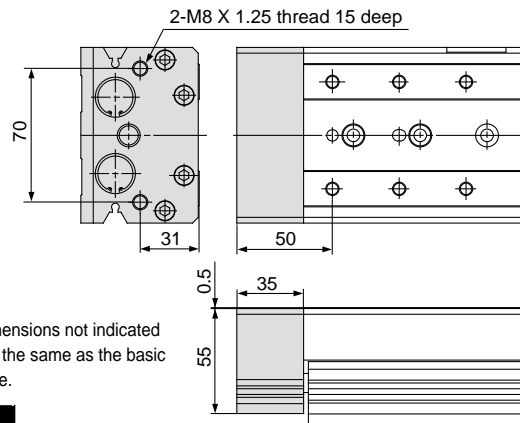

* Dimensions not indicated are the same as the basic style.



MXS25-50R.....SMXS25, #3(#1+#6)

Axial piping(ø25) MXS25-□□P

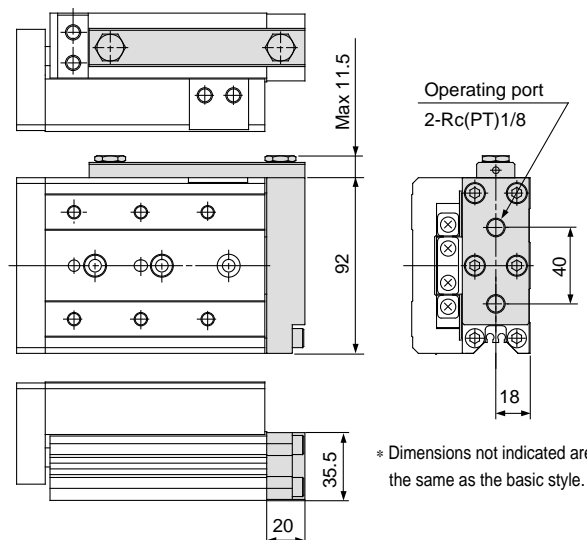

* Dimensions not indicated are the same as the basic style.



MXS25-50P.....SMXS25, #5(#1+#5+#6)

CL

MLGC

CNA

CB

CV/MVG

CXW

CXS

CXT

MX

MXU

MXS

MXQ

MXF

MXW

MXP

MG

MGP

MGQ

MGG

MGC

MGF

CY1

MY1

Series MXS

Option Specifications

Dimensions of Stroke Adjuster at Extension End

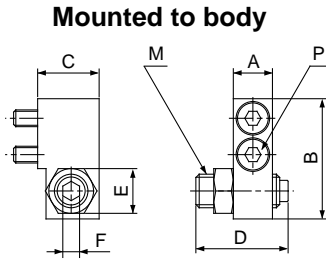

Mounted to table

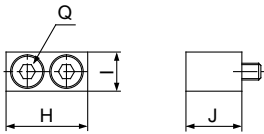

Model	Adjuster Part No.	Adjustable stroke range (mm)	Body mounted								Table mounted			
			A	B	C	D	E	F	M	P*	H	I	J	Q*
MXS 6	MXS-AS6	5	6	17.8	10.5	16.5	7	2.5	M5 X 0.8	M2.5 X 10	12.5	6	8.5	M2.5 X 8
	MXS-AS6-X11	15				26.5								
MXS 8	MXS-AS8	5	7	21.5	11	16.5	8	3	M6 X 1	M3 X 12	14.6	7	10	M3 X 10
	MXS-AS8-X11	15				26.5								
	MXS-AS8-X12	25				36.5								
MXS12	MXS-AS12	5	9.5	31	16	30	12	4	M8 X 1	M4 X 15	18.5	10	13	M4 X 12
	MXS-AS12-X11	15				40								
	MXS-AS12-X12	25				40								
MXS16	MXS-AS16	5	11	37	19	24.5	14	5	M10 X 1	M5 X 18	21	12	16.5	M5 X 18
	MXS-AS16-X11	15				34.5								
	MXS-AS16-X12	25				44.5								
MXS20	MXS-AS20	5	13	45.5	24	27.5	17	6	M12 X 1.25	M6 X 20	25	13	21	M6 X 20
	MXS-AS20-X11	15				37.5								
	MXS-AS20-X12	25				47.5								
MXS25	MXS-AS25	5	16	53.5	26.5	32.5	19	6	M14 X 1.5	M8 X 25	31	17	25.5	M8 X 25
	MXS-AS25-X11	15				42.5								
	MXS-AS25-X12	25				52.5								

* Size of hexagon socket head cap screws

Dimensions of Stroke Adjuster at Retraction End

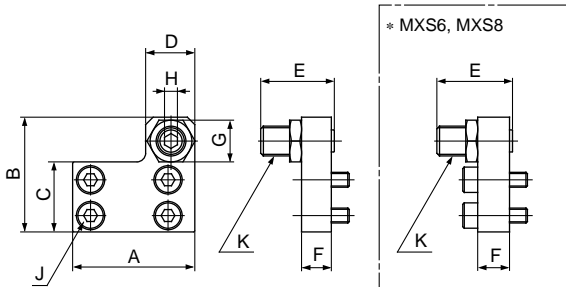

Model	Adjuster Part No.	Adjustable stroke range (mm)	A	B	C	D	E	F	G	H	J*	K
MXS 6	MXS-AT6	5	21	19	10.5	8	16.5	5	7	2.5	M2.5 X 8	M5 X 0.8
	MXS-AT6-X11	15					26.5					
MXS 8	MXS-AT8	5	25	22.5	12.5	9	16.5	6	8	3	M3 X 10	M6 X 1
	MXS-AT8-X11	15					26.5					
	MXS-AT8-X12	25					36.5					
MXS12	MXS-AT12	5	32	31	18.5	13	20	8	12	4	M4 X 8	M8 X 1
	MXS-AT12-X11	15					30					
	MXS-AT12-X12	25					40					
MXS16	MXS-AT16	5	40	38.5	23	15	24.5	10	14	5	M5 X 10	M10 X 1
	MXS-AT16-X11	15					34.5					
	MXS-AT16-X12	25					44.5					
MXS20	MXS-AT20	5	50	48	29	21	27.5	12	17	6	M5 X 12	M12 X 1.25
	MXS-AT20-X11	15					37.5					
	MXS-AT20-X12	25					47.5					
MXS25	MXS-AT25	5	60	58	35	23	32.5	15	19	6	M6 X 16	M14 X 1.5
	MXS-AT25-X11	15					42.5					
	MXS-AT25-X12	25					52.5					

* Size of hexagon socket head cap screws

How to Order Stroke Adjuster (Options)

MXS — AS 12 L — X11

Stroke adjuster

AS	Stroke adjuster	Extension end
AT	Stroke adjuster	Retraction end
BS	Shock absorber	Extension end
BT	Shock absorber	Retraction end

Bore

6	ø6
8	ø8
12	ø12
16	ø16
20	ø20
25	ø25

Symmetric style

—	Standard
L	Symmetric

Adjustable range (Stroke adjuster only)

—	5mm	Standard
-X11	15mm	Option
-X12	25mm	

- * -X12 (adjustable range: 25mm) is not available for MXS6.
- * -X11 and -X12 are not available for shock absorber type.
- * Shock absorber is not available on series MXS6.
- * -X11 and -X12 adjusters cannot be ordered assembled with MXS.
- * Refer to the above figures for the dimensions.

Option Specifications

Dimensions of Adjuster Option/With Shock Absorber (BS, BT)

Extension End

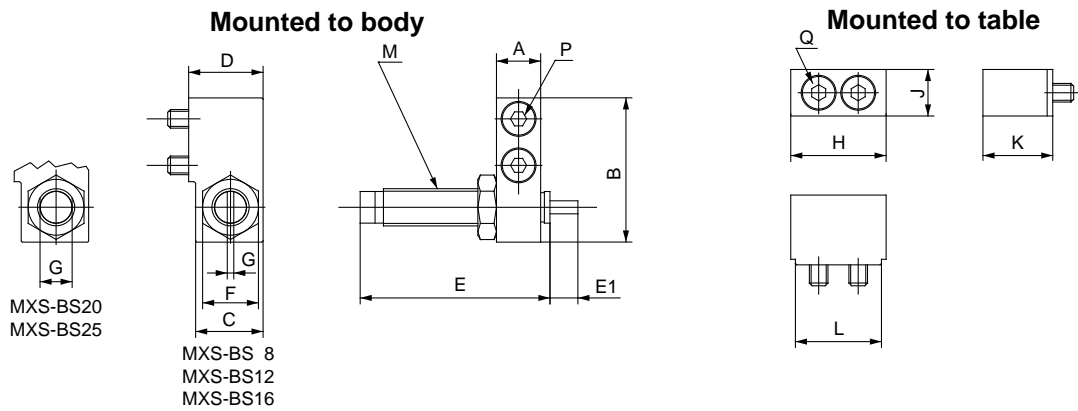

Model	Adjuster Part No.	Mounted to body										Mounted to table				
		A	B	C	D	E	E1	F	G	M	P*	H	J	K	L	Q*
MXS 8	MXS-BS 8	7	23	14	15.5	40.8	5	12	1.4	M8 X 1	M3 X 16	16.6	7	15.5	14.6	M3 X 16
MXS12	MXS-BS12	9.5	31	14.5	16	40.8	6	12	1.4	M8 X 1	M4 X 15	20.5	10	15	18.5	M4 X 15
MXS16	MXS-BS16	11	37	17.5	19	46.7	7	14	1.4	M10 X 1	M5 X 18	23	12	18.5	21	M5 X 18
MXS20	MXS-BS20	13	47	23.5	26	67.3	11	19	12	M14 X 1.5	M6 X 25	27	13	25.5	25	M6 X 25
MXS25	MXS-BS25	16	53.5	23.5	26.5	67.3	12	19	12	M14 X 1.5	M8 X 25	33	17	25.5	31	M8 X 25

* Size of hexagon socket head cap screw

Retraction End

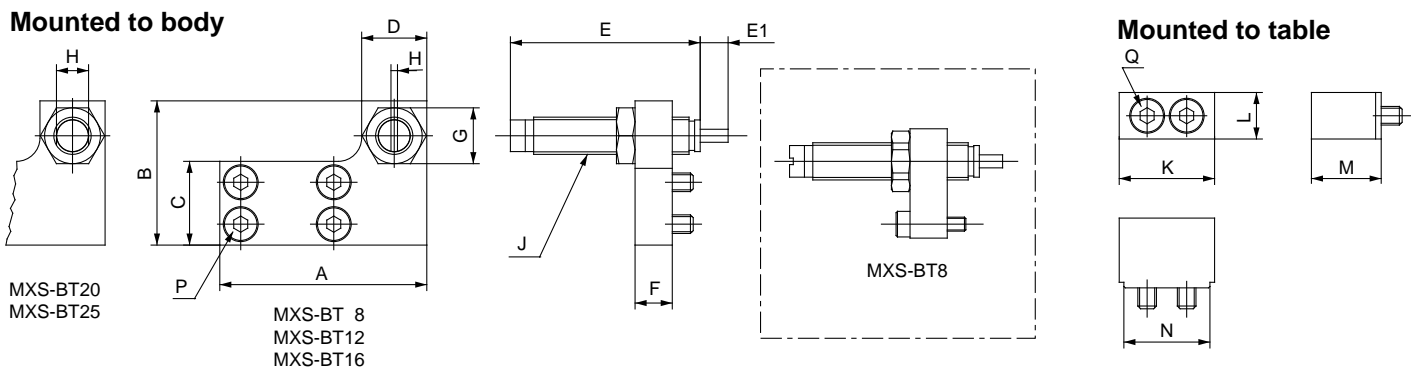

Model	Adjuster Part No.	Mounted to body											Mounted to table				
		A	B	C	D	E	E1	F	G	H	J	P ^{*1)}	K	L	M	N	Q*
MXS 8	MXS-BT 8	38	23	12.5	14	40.8	5	8	12	1.4	M8 X 1	M3 X 12	16.6	7	15.5	14.6	M3 X 16
MXS12	MXS-BT12	45	31	18	14	40.8	6	8	12	1.4	M8 X 1	M4 X 8	20.5	10	15	18.5	M4 X 15
MXS16	MXS-BT16	55	37	23.5	16	46.7	7	10	14	1.4	M10 X 1	M5 X 10	23	12	18.5	21	M5 X 18
MXS20	MXS-BT20	70	47	29	23	67.3	11	12	19	12	M14 X 1.5	M5 X 12	27	13	25.5	25	M6 X 25
MXS25	MXS-BT25	80	54	35	23	67.3	12	15	19	12	M14 X 1.5	M6 X 16	33	17	25.5	31	M8 X 25

* Size of hexagon socket head cap screw

- CL
- MLGC
- CNA
- CB
- CV/MVG
- CXW
- CXS
- CXT
- MX
- MXU
- MXS**
- MXQ
- MXF
- MXW
- MXP
- MG
- MGP
- MGQ
- MGG
- MGC
- MGF
- CY1
- MY1

Series MXS

Shock Absorber Specifications

Shock absorber part No.	RB0805	RB0806	RB1007	RB1411	RB1412	
Applicable slide table	MXS8	MXS12	MXS16	MXS20	MXS25	
Max. absorbing energy (J)	0.98	2.94	5.88	14.7	19.6	
Absorbing stroke (mm)	5	6	7	11	12	
Max. collision speed (mm/s)	50 to 500					
Max. operating frequency (cycle/min)	80	80	70	45	45	
Max. allowable thrust (N)	245	245	422	814	814	
Ambient and fluid temperature (°C)	-10 to 60					
Spring force (N)	Extended	1.96	1.96	4.22	6.86	6.86
	Retracted	3.83	4.22	6.86	15.30	15.98
Weight (g)	15	15	25	65	65	

End Lock Specifications

Model	MXS8	MXS12	MXS16	MXS20	MXS25
Bore size (mm)	8	12	16	20	25
Operating speed range	50 to 500mm/s				
Holding force (N)	25	60	110	160	250

Note) Refer to p.3.11-5 for cautions on end lock.

Buffer Specifications

Model	MXS6	MXS8	MXS12	MXS16	MXS20	MXS25	
Bore size (mm)	6	8	12	16	20	25	
Piston speed	50 to 500mm/s (Horizontal mounting 50 to 300mm/s)						
Buffer stroke (mm)	5			10			
Buffer stroke load (N)	At 0mm stroke	3	5	10	13	17	21
	At max. stroke	6	8	13	17	25	29

Note) Refer to p.3.11-5 for cautions on buffer.

Note) If stroke is adjusted with the stroke adjuster at extension end, the buffer stroke is shortened by the adjusted length.

Applicable Auto Switches to Buffer

Style	Part No.	Specifications	Electrical entry
Solid state switch	D-F9BV	With light, 2 wire	Perpendicular
	D-F9NV	With light, 3 wire, Output: NPN	
	D-F9PV	With light, 3 wire, Output: PNP	

* The auto switch for buffer must be ordered separately.



With buffer

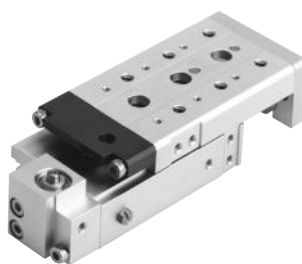

With end lock

Construction

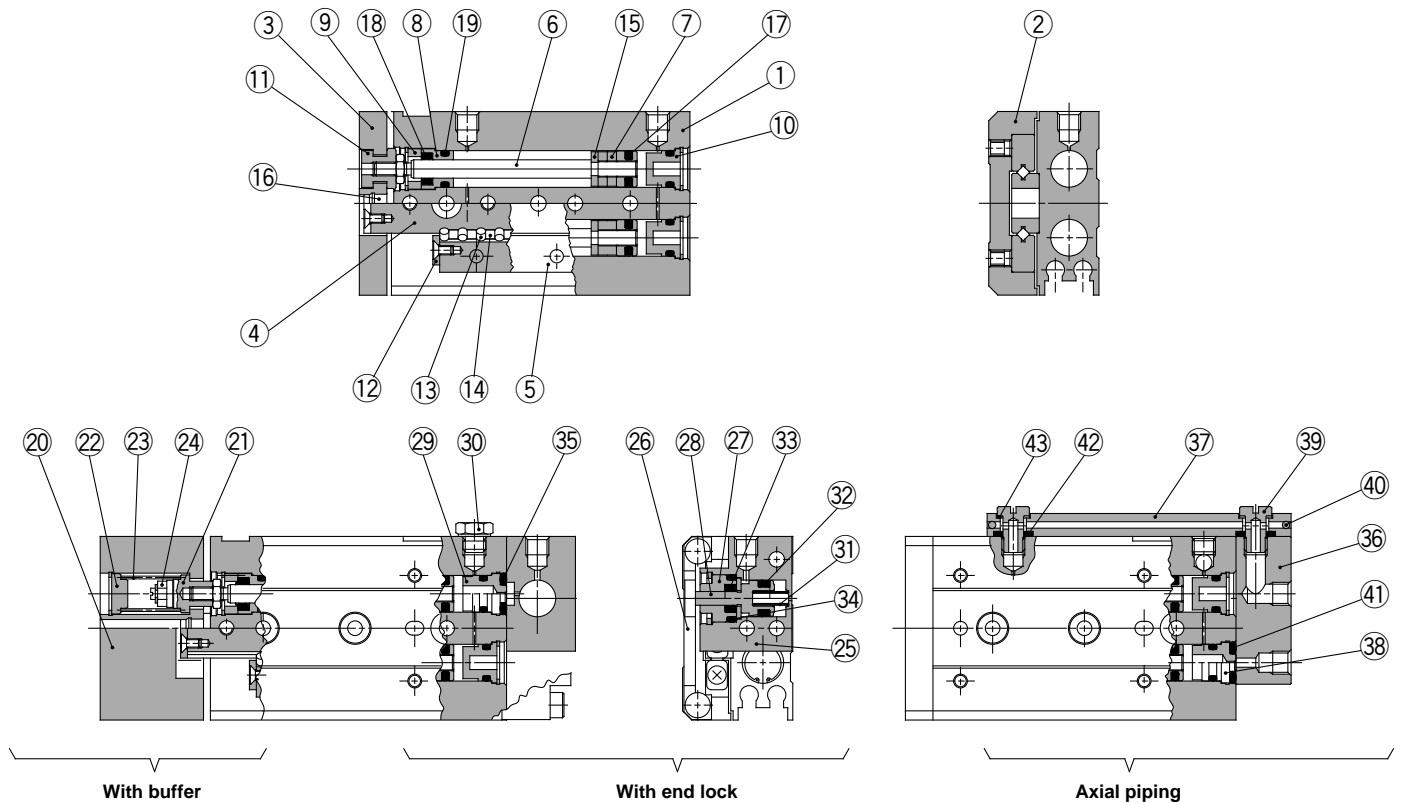

Component Parts

No.	Description	Material	Note
①	Body	Aluminum alloy	Hard anodized
②	Table	Aluminum alloy	Hard anodized
③	End plate	Aluminum alloy	Hard anodized
④	Rail	Carbon tool steel	Heat treatment
⑤	Guide	Carbon tool steel	Heat treatment
⑥	Rod	Stainless steel	
⑦	Piston assembly		With one side magnet
⑧	Rod cover	Aluminum alloy	Anodized
⑨	Seal support	Brass	Electroless nickel plated
⑩	Head cap	Resin	
⑪	Floating bushing	Stainless steel	
⑫	Roller stopper	Stainless steel	
⑬	Cylindrical roller	High carbon chromium bearing steel	
⑭	Roller spacer	Resin	
⑮	Rod bumper	Polyurethane	
⑯	End bumper	Polyurethane	
⑰	Piston seal	NBR	
⑱	Rod seal	NBR	
⑲	O ring	NBR	

Component Parts/With buffer

No.	Description	Material	Note
⑳	End plate	Aluminum alloy	Hard anodized
㉑	Spring collar	Stainless steel	
㉒	Head cap	Stainless steel	
㉓	Spring	Stainless steel	
㉔	Magnet	Rare earth	

Replacement Parts: Seal Kits

Bore (mm)	Kit No.	Contents
6	MXS6-PS	1 set including ⑰ to ⑲
8	MXS8-PS	
12	MXS12-PS	
16	MXS16-PS	
20	MXS20-PS	
25	MXS25-PS	

Replacement Parts: Seal Kits for End Lock Model

Bore (mm)	Kit No.	Contents
8	MXS8R-PS	1 set including ⑰ to ⑲ & ㉒ to ㉔
12	MXS12R-PS	
16	MXS16R-PS	
20	MXS20R-PS	
25	MXS25R-PS	

Replacement Parts: Seal kits for Axial Piping Model

Bore (mm)	Kit No.	Contents
6	MXS6P-PS	1 set including ⑰ to ⑲ & ㉑ to ㉓
8	MXS8P-PS	
12	MXS12P-PS	
16	MXS16P-PS	
20	MXS20P-PS	
25	MXS25P-PS	

Component Parts/With end lock

No.	Description	Material	Note
㉕	Body for lock	Aluminum alloy	Hard anodized
㉖	Table support	Carbon steel	Anticorrosive treatment
㉗	Rod cover	Aluminum alloy	
㉘	Piston rod	Stainless steel	
㉙	Bushing	Aluminum alloy	Chromated
㉚	Blanking plug	Brass	Electroless nickel plated
㉛	Return spring	Stainless steel	
㉜	Piston seal	NBR	
㉝	Rod seal	NBR	
㉞	O ring	NBR	
㉟	O ring	NBR	

Component Parts/Axial piping

No.	Description	Material	Note
㉞	Axial side piping plate	Aluminum alloy	Hard anodized
㉟	Pipe	Aluminum alloy	Hard anodized
㊱	Bushing	Aluminum alloy	Chromated
㊲	Stud	Brass	Electroless nickel plated
㊳	Steel ball	Stainless steel	
㊴	O ring	NBR	
㊵	O ring	NBR	
㊶	Gasket		

* The parts indicated with the numbers in the list below are included in a seal kit. Specify the order numbers in compliance with respective cylinder bore size.

CL
MLGC
CNA
CB
CV/MVG
CXW
CXS
CXT
MX
MXU
MXS
MXQ
MXF
MXW
MXP
MG
MGP
MGQ
MGG
MGC
MGF
CY1
MY1

Air Slide Table (Symmetric Style) Series **MXS□L**

How to Order

Air slide table

MXS 12 L — 50 AS — F9N S

• Symmetric style

• Number of auto switches

—	2
S	1
n	n

• Bore size (Stroke: mm)

6	10, 20, 30, 40, 50
8	10, 20, 30, 40, 50, 75
12	10, 20, 30, 40, 50, 75, 100
16	10, 20, 30, 40, 50, 75, 100, 125
20	10, 20, 30, 40, 50, 75, 100, 125, 150
25	10, 20, 30, 40, 50, 75, 100, 125, 150

• Auto switch

—	Without auto switch
---	---------------------

*Refer to below table for parts No. of auto switch.

• Stroke adjuster option

—	Without adjuster
AS	Adjuster at extension end
AT	Adjuster at retraction end
A	Adjuster at both ends
BS⁽¹⁾	Absorber at extension end
BT⁽¹⁾	Absorber at retraction end
B⁽¹⁾	Absorber at both ends

Note 1) Shock absorber is not available for MXS6L.
Note 2) Functional option is not available for MXS□□L.

Applicable Auto Switches/Refer to p.5.3-2 for further information on auto switch.

Style	Special function	Electrical entry	Indicator	Wiring (Output)	Load voltage		Auto switch model		Lead wire (m)		Load	Specification details		
					DC	AC	Electrical entry		0.5 (—)	3 (L)				
							Perpendicular	In-line						
Reed switch	—	Grommet	No	2 wire	24V	5V, 12V	100V or less	A90V	A90	●	●	IC circuit	P.5.3-19	
			Yes	3 wire(Equiv. NPN)		12V	100V	A93V	A93	●	●	—		Relay, PLC
			Yes	3 wire(NPN)	—	5V	—	A96V	A96	●	●	IC circuit		—
Solid state switch	Diagnostic indication (2 color)	Grommet	Yes	3 wire(NPN)	24V	12V	—	F9NV	F9N	●	●	—	Relay, PLC	P.5.3-39
				3 wire(PNP)				F9PV	F9P	●	●			
				2 wire				F9BV	F9B	●	●			
	3 wire(NPN)			F9N WV				F9N W	●	●				
	3 wire(PNP)			F9P WV				F9P W	●	●				
	2 wire			F9B WV				F9B W	●	●				
—	—	Grommet	Yes	3 wire(NPN)	24V	12V	—	F9NV	F9N	●	●	—	Relay, PLC	P.5.3-66
				3 wire(PNP)				F9PV	F9P	●	●			
				2 wire				F9BV	F9B	●	●			
3 wire(NPN)	F9N WV	F9N W	●	●										
3 wire(PNP)	F9P WV	F9P W	●	●										
2 wire	F9B WV	F9B W	●	●										

*Lead wire length 0.5m..... (Ex.) A93
3m..... L A93L

PLC: Programmable Logic Controller

Specifications

Specifications are same as the standard style. Refer to p.3.11-7



Series MXS

Dimensions MXS 8L/Symmetric style

Basic style

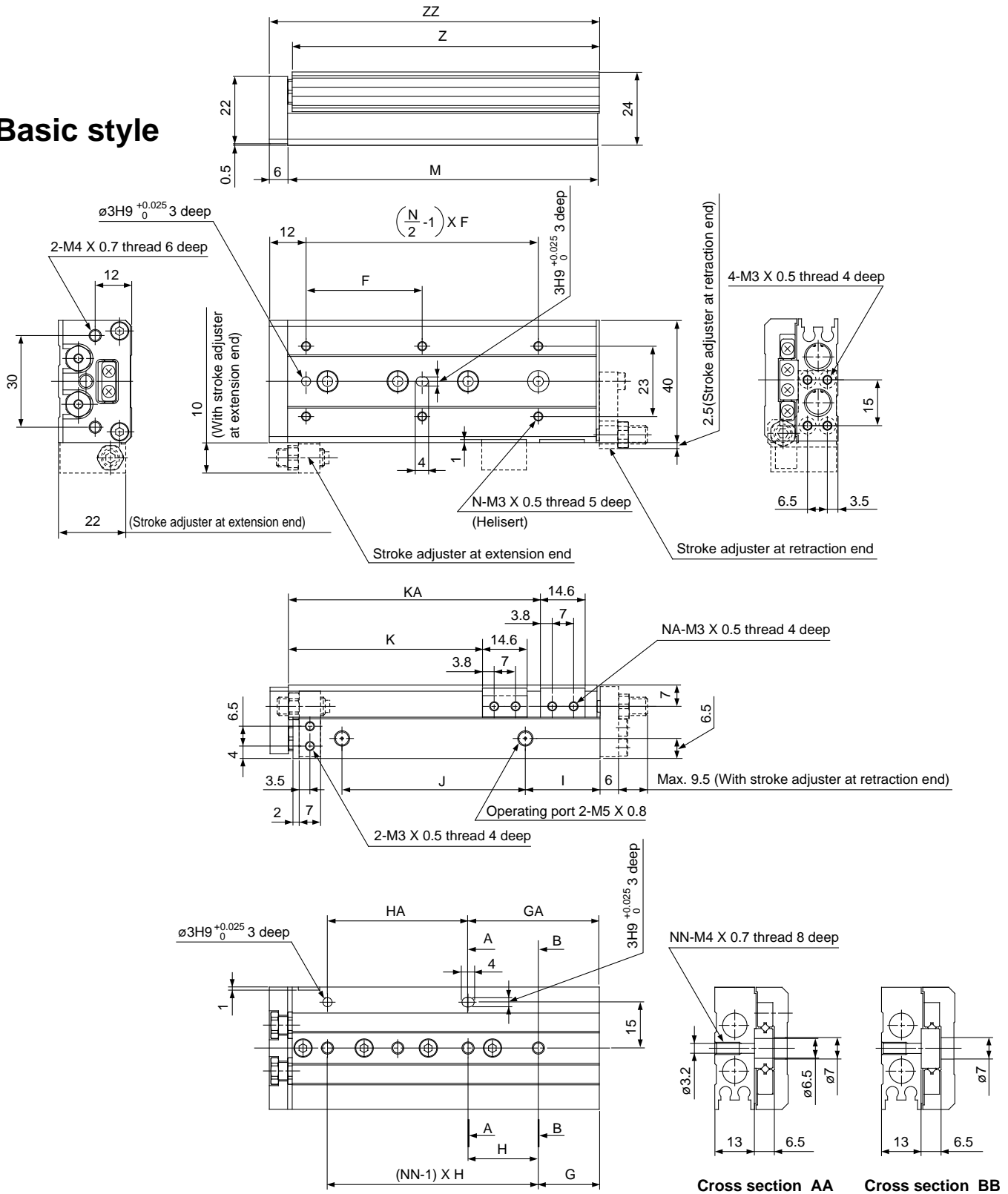

Model	F	N	G	H	NN	GA	HA	I	J	K	KA	NA	M	Z	ZZ
MXS8L-10	25	4	9	28	2	17	20	13	19.5	23.5	—	2	49	48.5	56
MXS8L-20	25	4	12	30	2	12	30	8.5	29	33.5	—	2	54	53.5	61
MXS8L-30	40	4	13	20	3	33	20	9.5	39	43.5	—	2	65	64.5	72
MXS8L-40	50	4	15	28	3	43	28	10.5	56	53.5	—	2	83	82.5	90
MXS8L-50	38	6	20	23	4	43	46	24.5	60	63.5	82.5	4	101	100.5	108
MXS8L-75	50	6	27	28	5	83	56	38.5	96	88.5	132.5	4	151	150.5	158

(mm)



Refer to "Dimensions" of MXS8 on p.3.11-15 for one with shock absorber as symmetric.

Series MXS

Dimensions MXS 16L/Symmetric style

Basic style

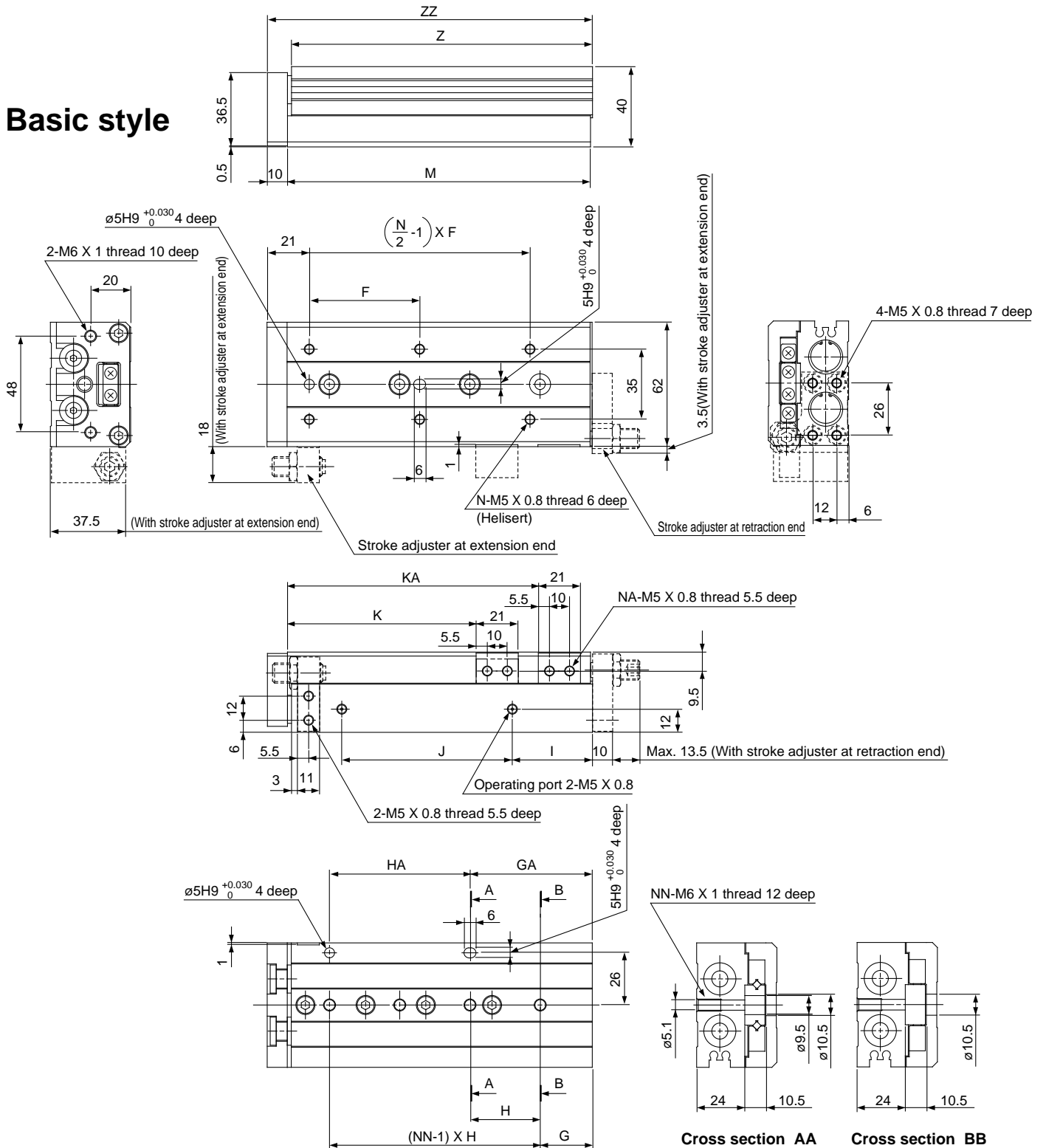

(mm)

Model	F	N	G	H	NN	GA	HA	I	J	K	KA	NA	M	Z	ZZ
MXS16L-10	35	4	16	40	2	16	40	10	40	29	—	2	76	75	87
MXS16L-20	35	4	16	40	2	16	40	10	40	39	—	2	76	75	87
MXS16L-30	35	4	16	40	2	16	40	10	40	49	—	2	76	75	87
MXS16L-40	40	4	16	50	2	16	50	10	50	59	—	2	86	85	97
MXS16L-50	30	6	21	30	3	51	30	15	60	69	—	2	101	100	112
MXS16L-75	55	6	26	35	4	61	70	40	85	94	125	4	151	150	162
MXS16L-100	65	6	39	35	5	109	70	55	118	119	173	4	199	198	210
MXS16L-125	70	8	19	35	7	159	70	68	155	144	223	4	249	248	260



Refer to "Dimensions" of MXS 16 on p.3.11-19 for one with shock absorber as symmetric.

MXS 20L/Symmetric style

Basic style

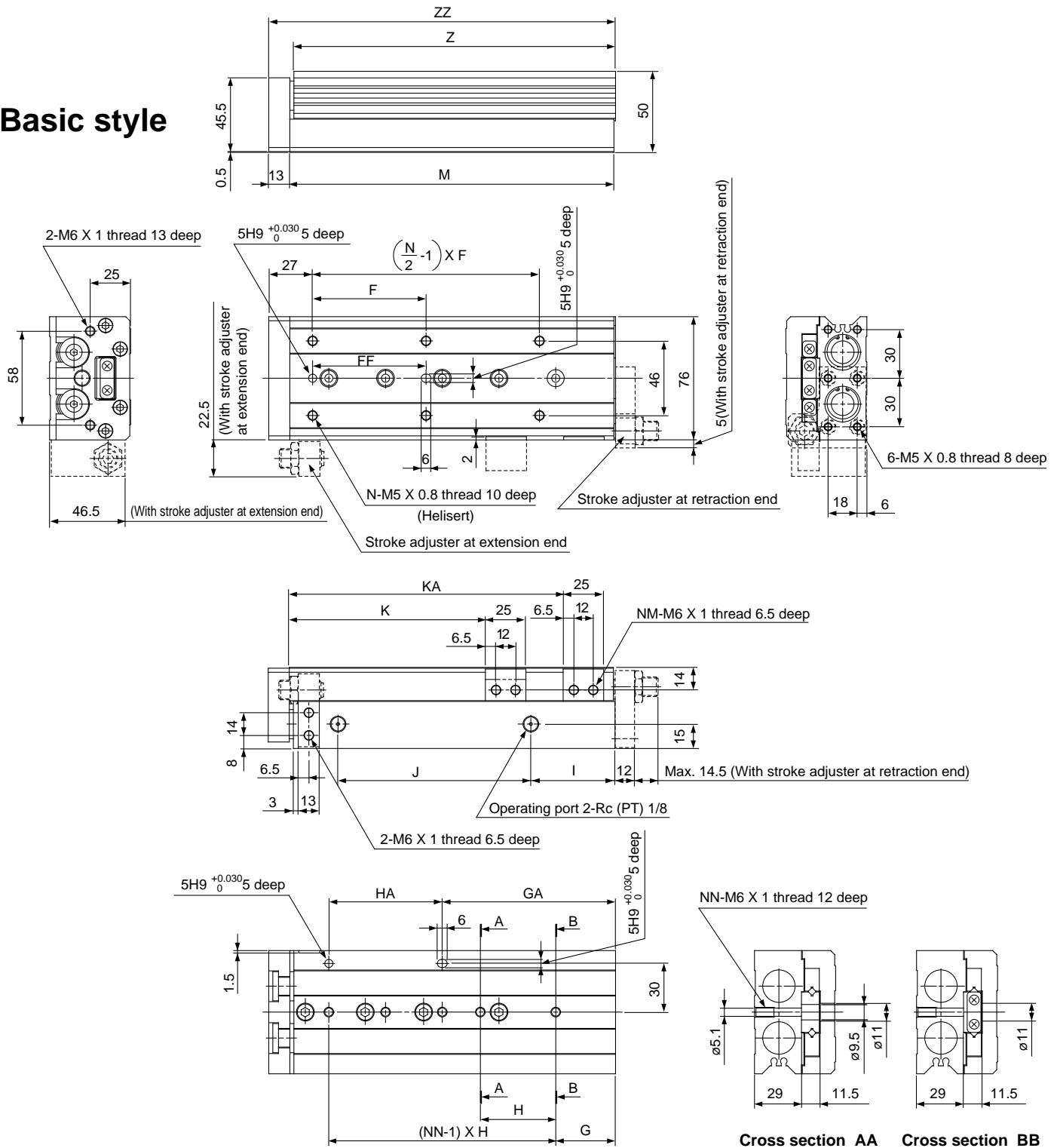

- CL
- MLGC
- CNA
- CB
- CV/MVG
- CXW
- CXS
- CXT
- MX
- MXU
- MXS**
- MXQ
- MXF
- MXW
- MXP
- MG
- MGP
- MGQ
- MGG
- MGC
- MGF
- CY1
- MY1

Model	F	FF	N	G	H	NN	GA	HA	I	J	K	KA	NA	M	Z	ZZ
MXS20L-10	50	40	4	15	45	2	25	35	10	44	31	—	2	83	81.5	97
MXS20L-20	50	40	4	15	45	2	25	35	10	44	41	—	2	83	81.5	97
MXS20L-30	50	40	4	15	45	2	25	35	10	44	51	—	2	83	81.5	97
MXS20L-40	60	50	4	15	55	2	35	35	10	54	61	—	2	93	91.5	107
MXS20L-50	35	35	6	15	35	3	50	35	10	69	71	—	2	108	106.5	122
MXS20L-75	60	60	6	19	35	4	54	70	10	108	96	—	2	147	145.5	161
MXS20L-100	70	70	6	37	35	5	107	70	58	113	121	169	4	200	198.5	214
MXS20L-125	70	70	8	41	38	6	155	76	70	155	146	223	4	254	252.5	268
MXS20L-150	80	80	8	19	44	7	195	88	87	190	171	275	4	306	304.5	320

Refer to "Dimensions" of MXS20 on p.3.11-21 for one with shock absorber as symmetric.

Series MXS

Dimensions MXS 25L/Symmetric style

Basic style

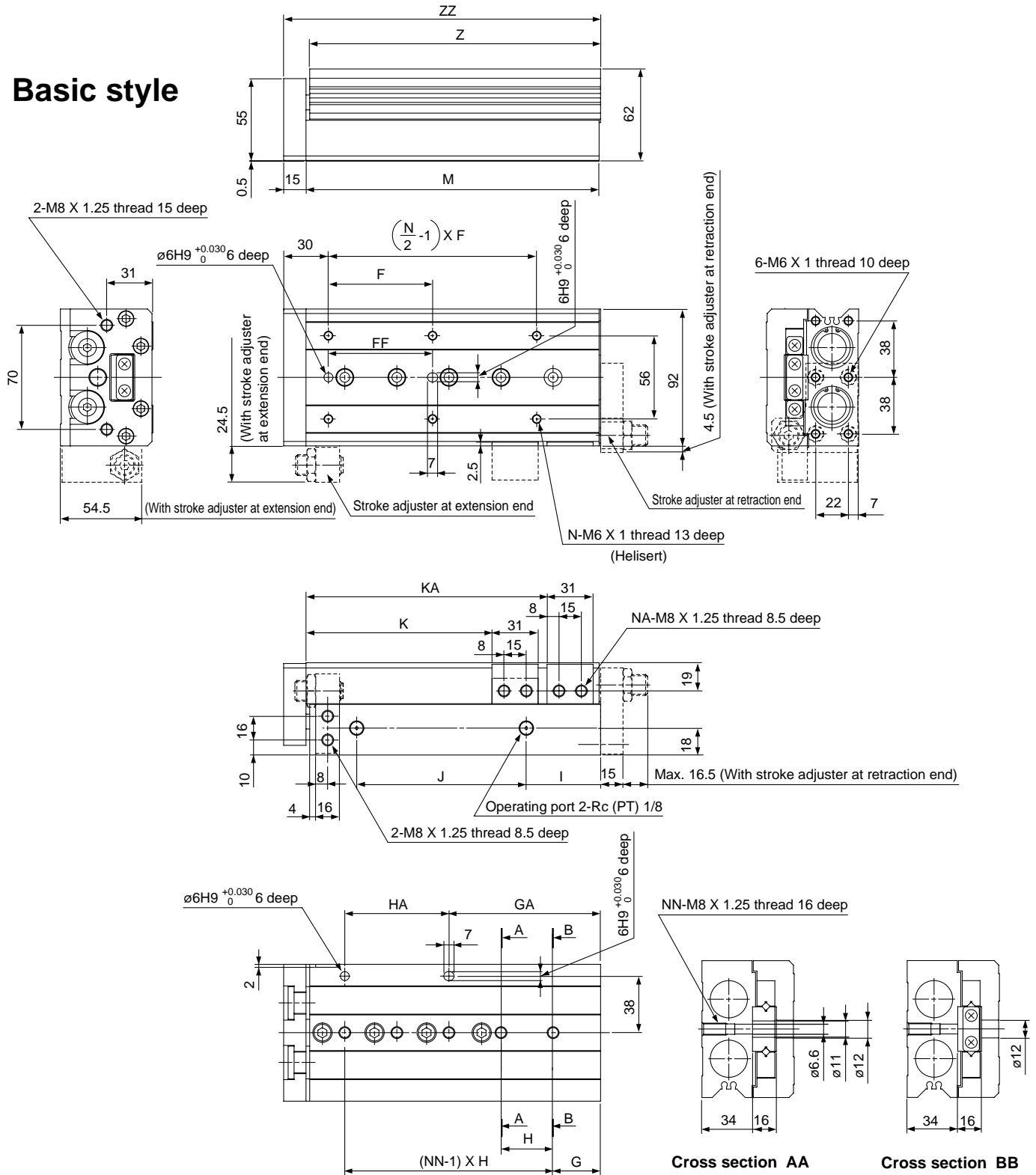

Model	F	FF	N	G	H	NN	GA	HA	I	J	K	KA	NA	M	Z	ZZ
MXS25L-10	50	40	4	22	45	2	22	45	12	47	35	—	2	92	90.5	108
MXS25L-20	50	40	4	22	45	2	22	45	12	47	45	—	2	92	90.5	108
MXS25L-30	50	40	4	22	45	2	22	45	12	47	55	—	2	92	90.5	108
MXS25L-40	60	50	4	22	55	2	22	55	12	57	65	—	2	102	100.5	118
MXS25L-50	35	35	6	20	35	3	55	35	12	70	75	—	2	115	113.5	131
MXS25L-75	60	60	6	26	35	4	61	70	33	90	100	—	2	156	154.5	172
MXS25L-100	70	70	6	32	35	5	102	70	50	114	125	162	4	197	195.5	213
MXS25L-125	75	75	8	40	38	6	154	76	67	155	150	218	4	255	253.5	271
MXS25L-150	80	80	8	30	40	7	190	80	82	180	175	258	4	295	293.5	311

Refer to "Dimensions" of MXS25 on p.3.11-23 for one with shock absorber as symmetric.

Auto Switch Mounting Position for Stroke End Detection

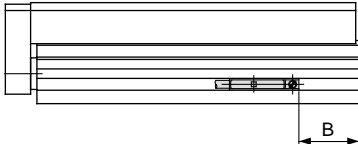
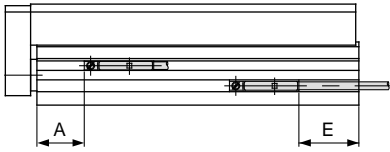

Reed switch: D-A90, D-A93, D-A96, D-A90V, D-A93V, D-A96V

Model	A	B										E										Operating range
		Stroke										Stroke										
		10	20	30	40	50	75	100	125	150	10	20	30	40	50	75	100	125	150			
MXS6	5.9	5.6	5.6	5.6	17.6	23.6	—	—	—	—	3.6 (1.1)	3.6 (1.1)	3.6 (1.1)	15.6 (13.1)	21.6 (19.1)	—	—	—	—	4.5		
MXS8	7.6	10.9	5.9	6.9	14.9	22.9	47.9	—	—	—	8.9 (6.4)	3.9 (1.4)	4.9 (2.4)	12.9 (10.4)	20.9 (18.4)	45.9 (43.4)	—	—	—	5		
MXS12	11.6	28.4	18.4	8.4	10.4	20.4	41.4	70.4	—	—	26.4 (23.9)	16.4 (13.9)	6.4 (3.9)	8.4 (5.9)	18.4 (15.9)	39.4 (36.9)	68.4 (65.9)	—	—	—	6	
MXS16	16.3	28.7	18.7	8.7	8.7	13.7	38.7	61.7	86.7	—	26.7 (24.2)	16.7 (14.2)	6.7 (4.2)	6.7 (4.2)	11.7 (9.2)	36.7 (34.2)	59.7 (57.2)	84.7 (82.2)	—	—	7	
MXS20	18.9	32.6	22.6	12.6	12.6	17.6	31.6	59.6	88.6	115.6	30.6 (28.1)	20.6 (18.1)	10.6 (8.1)	10.6 (8.1)	15.6 (13.1)	29.6 (27.1)	57.6 (55.1)	86.6 (84.1)	113.6 (111.1)	—	8	
MXS25	23	37.5	27.5	17.5	17.5	20.5	36.5	52.5	85.5	100.5	35.5 (33)	25.5 (23)	15.5 (13)	15.5 (13)	18.5 (16)	24.5 (22)	50.5 (48)	83.5 (81)	98.5 (96)	—	8	

() : D-F9N

Solid state switch: D-F9B, D-F9N, D-F9P, D-F9BW, D-F9NW, D-F9PW

Model	A	B										E										Operating range
		Stroke										Stroke										
		10	20	30	40	50	75	100	125	150	10	20	30	40	50	75	100	125	150			
MXS6	10	9.6	9.6	9.6	21.6	27.6	—	—	—	—	-0.4	-0.4	-0.4	11.6	17.5	—	—	—	—	2		
MXS8	11.6	14.9	9.9	10.9	18.9	26.9	51.9	—	—	—	4.9	-0.1	0.9	8.9	16.9	41.9	—	—	—	2.5		
MXS12	15.6	32.4	22.4	12.4	14.4	24.4	45.4	74.4	—	—	22.4	12.4	2.4	4.4	14.4	35.4	64.4	—	—	3		
MXS16	20.3	32.7	22.7	12.7	12.7	17.7	42.7	65.7	90.7	—	22.7	12.7	2.7	2.7	7.7	32.7	55.7	80.7	—	4		
MXS20	22.9	36.6	26.6	16.6	16.6	21.6	35.6	63.6	92.6	119.6	26.6	16.6	6.6	6.6	11.6	25.6	53.6	82.6	109.6	6		
MXS25	27	41.5	31.5	21.5	21.5	24.5	40.5	56.5	89.5	104.5	31.5	21.5	11.5	11.5	14.5	30.5	46.5	79.5	94.5	6		

Solid state switch: D-F9BV, D-F9NV, D-F9PV, D-F9BWV, D-F9NWV, D-F9PWV

Model	A	B										E										Operating range
		Stroke										Stroke										
		10	20	30	40	50	75	100	125	150	10	20	30	40	50	75	100	125	150			
MXS6	10	9.6	9.6	9.6	21.6	27.6	—	—	—	—	1.6	1.6	1.6	13.6	19.6	—	—	—	—	2		
MXS8	11.6	14.9	9.9	10.9	18.9	26.9	51.9	—	—	—	6.9	1.9	2.9	10.9	18.9	43.9	—	—	—	2.5		
MXS12	15.6	32.4	22.4	12.4	14.4	24.4	45.4	74.4	—	—	24.4	14.4	4.4	6.4	16.4	37.4	66.4	—	—	3		
MXS16	20.3	32.7	22.7	12.7	12.7	17.7	42.7	65.7	90.7	—	24.7	14.7	4.7	4.7	9.7	34.7	57.7	82.7	—	4		
MXS20	22.9	36.6	26.6	16.6	16.6	21.6	35.6	63.6	92.6	119.6	28.6	18.6	8.6	8.6	13.6	27.6	55.6	84.6	111.6	6		
MXS25	27	41.5	31.5	21.5	21.5	24.5	40.5	56.5	89.5	104.5	33.5	23.5	13.5	13.5	16.5	32.5	48.5	81.5	96.5	6		

How to Install an Auto Switch

⚠ Caution

Auto switch mounting tool

- To tighten the set screw (attached to the auto switch), use a watch maker's screwdriver with a grip diameter of 5 to 6mm.

Clamping torque

- Clamping torque is approx. 0.05 to 0.1Nm. Rotate about 90° from when you feel the fitting tightness.

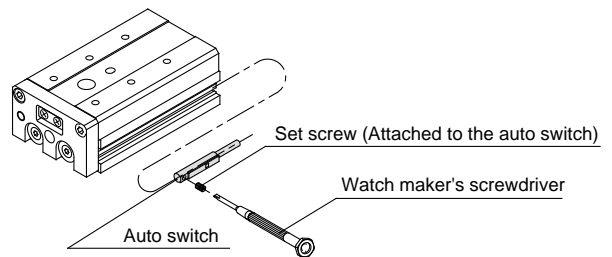

CL

MLGC

CNA

CB

CV/MVG

CXW

CXS

CXT

MX

MXU

MXS

MXQ

MXF

MXW

MXP

MG

MGP

MGQ

MGG

MGC

MGF

CY1

MY1